



MANIOI  
PF01

1/5 SCALE ATOM  
HUMANOID SAM

**MANIOI**  
PF01  
パーフェクトガイド

京西株式会社・監修  
味みきお・監

KYOSHO

1/5スケールヒューマノイドロボットキット「MANIOI PF01」

**マノイとのつきあいかた、  
教えます。**

組み立てのコツ、  
動かすためのプログラム、  
遊び方まで一挙紹介!



Before beginning assembly, please read these instructions thoroughly.

**1/5 SCALE ATHLETE HUMANOID SERIES**

**MANO1**  
**PF01**

Read this first

Thank you for purchasing of MANO1™ PF01 the bipedal walking Robot Assembling Kit.

This instruction is about assembling and operating of MANO1™ PF01. Please, read this carefully and assemble with caution.

\*Specifications are subject to change without prior notice.





# Instruction

This product is Assembling Kit. And, it could happen that product can not perform fully if assembling or operating way is not correct. First-time builders should seek the advise of experienced robot user before beginning assembly and if they do not fully understand any part of the construction.

## Required Additional

Some equipments and tools which are not included in this product are required to assemble and operate this product. Please, prepare before starting.

### ○Personal Computer

- The one which can operate Microsoft Windows 2000 or Windows XP <sup>(\*1)</sup>
- The one which has more than 1port of USB Port <sup>(\*2)</sup>
- The one which has CD-ROM drive

\*1) This is not Windows Vista-compliant

\*2) Basically use USB port of the PC itself

### ○Tools

- KYOSHO Ratchet Cross Slot Screwdriver Set (MANO1) [No. HRP009]  
This set has Ratchet system to push and tighten screw. It also including 2 type of bits of #0 and #1.
- Cross Slot Screwdriver (#2)
- Double Faced Tape (thick one) This will be used for fixing Radio Controlled Unit

## About Screw Drivers

Cross Slot Screws are used for fixing parts of this product. And it is necessary to choose right size of the driver for each size of screw-head. It is recommended to use KYOSHO Ratchet Cross Slot Screwdriver Set (MANO1) [No. HRP012]. if incorrect size driver is used for wrong screw, it will mess screw-head. Be carefull for this.

#0	...	M2x5 Pan-head Tapping Screw	#1	...	M2. 6x8 Pan-head Tapping Screw
	...	M2x8 pan-head Tapping Sfcrow		...	M2. 6x10 Pan-head Tapping Screw
	...	M2x6 Pan-head Machine Screw		...	M2. 6x10 Countersank Tapping Screw
	...	M2x5 Countersank Tapping Screw		...	M2. 6x14 Pan-head Tapping Screw
	...	M2x8 Countersank Tapping Screw			
	...	M2x10 Countersank Tapping Screw	#2	...	M3x8 Bind Tapping Screw
	...	M2x20 countersank Tapping Screw			
	...	M2x16 countersank Tapping Screw			

\*「# ●」 means standardized size of screwdriver. It is indicated at handle of screwdriver. It will be reference for purchasing screwdriver.

## Tighten Screws

Screw which is called Tapping Screw is used for this product to fix plastic material part. This screw is special type of screw, so read below points carefully.

### ★ How to hold Screw Driver (example)

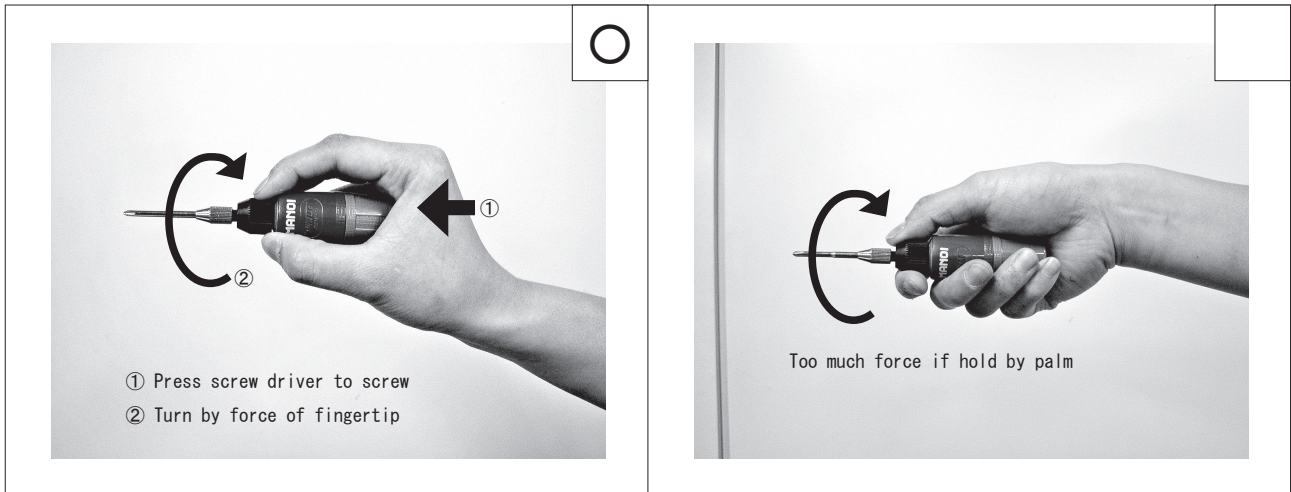

Tapping Screw is type of screw which is making screw thread inside of Plastic material as it is tightened. Therefore, when start tighten the screw it gets hard feeling. Push Tapping screw down to Screw hole to tighten.

Do not use electric screwdriver for Tapping Screw.

Make sure Tapping Screw is perpendicular to screw hole as tighten. If not, it may cause damage on Parts.

If it is found that Screw is not perpendicular to screw hole, lose screw and remove from screw hole. Then, make sure it is perpendicular and try again.

When feel very hard to tighten, check if Screw is perpendicular or not.

Tighten the screw until thread of Tapping Screw or head of screw of Pan-Head Screw get into inside of Plastic Parts. Thread is inside of parts and get hard feeling of tighten, it is enough.

Too tighten will cause mess of thread which is made inside of Parts. If mess thread, that screw hole will not be usefull to fix parts and need replacement parts, Especially Male can cause mess of thread by too much power for tighten. Be carefull of this,

If tightened screw is needed to be removed and tightened again, it is not necessary to push screw down to screw hole. Just make sure Screw is perpendicular to screw hole and tighten until enough.

When fix a parts by several screws, all of screw for fixing should not be tightened completely, stop tighten at 2/3, then tighten all of them completely. Order of tighten screws is 2nd screw which is tighten completely should be the farrest from 1st one.

# CONTENT

Safety Precautions .....	7
Component Parts .....	7
Charger and Li-Po Battery .....	8
Li-Po Battery .....	9
Accompanying Items .....	11
Actuator KRS-4024SHV .....	11
Control Board RGB-3HV Ver1.03 .....	11
Gyro-Sensor KRG-3 .....	11
Charger for Li-Po Battery [No. HRCH100] .....	12
Li-Po Battery [No. HRBA100] (for 1sell) .....	12
Icon Indication in assembling instruction .....	12
Parts List .....	13
Parts Views.....	17
Assembling .....	20
Operation 1:Preparation for Assembling .....	20
Operation 2:Set Neutral Positn of Servo Motor (Pack2, 11, 12).....	29
Operation 3:Assembling Right Arm (Pack3) .....	43
Operation 3:Assembling Left Arm (Pack4) .....	56
Operation 3:Assembling Right Leg (Pack5) .....	69
Operation 3:Assembling Left Leg (Pack6) .....	85
Operation 3:Assembling Head (Pack7) .....	101
Operation 3:Assembling Body (Pack8) .....	108
Setting Software .....	119
Operation S1: Preparation for Setting .....	119
Operation S2: Reverse Setting of Servo motor .....	123
Operation S3: Setting of Home Position .....	127
Operation S4: Setting of Gyro-Sensor .....	137
Operation S3: Registration of Sample Motion .....	143
How to play MOANI .....	147
Part 1: Operate by Wired Control .....	147
Part 2: Move by Automatic .....	150
Part 3: Creat Motions .....	157
Creat by setting numeric number on HTH3 .....	159
Creat by moving Arms and Legs (Teaching) .....	169

安全のための  
注意事項

付属製品に  
ついて

組み立て

ソフトウェア  
の設定

MOANI  
遊び方

での

オプションパー  
ツの取り付け

故障かなと  
思ったら

ユーザー相談  
室のご案内

用語集

パーツ販売  
リスト

展開図





Attaching Option Parts .....	178
OPO1 : Control by Radio Controlled system	
(Attaching Radio Controlled system) .....	178
Trouble Shooting .....	197
Customer Service Information .....	201
Lexicon .....	202
Sales Parts List.....	203
MANOI™PF01 Exploded View .....	206

# Safety Precautions

This product is "Assembling Kit", therefore, it could be called upon to take personal responsibility for using way/result. Use this product with fully understanding on this point. This instruction shows Sign indication for preventing damage on user, other people, or assets as follows,

 **Danger** This sign indicates assumable danger which may cause death or serious injury can be happened.

 **Warning** This sign indicates assumable possibility which may cause death or serious injury can be happened.

 **Caution** This sign indicates assumable possibility which may cause injury or damage can be happened.

## Component Parts

 **Warning**

- ★Make sure that children are not around this product when operation/using.  
By falling over or unexpected movement, it could cause accident or injury.
- ★Keep Children away from small parts.  
Some parts are sharp to cause injury and small parts can be swallowed by accident or mistake.
- ★Do not disassemble or modify Servo Motor and PC board without any instruction  
Servo Motor and PC Board are precision electronic part, so disassemble or modify without any instruction may cause short circuit or fire. For failure is found, contact The shop where you purchased.
- ★Do not get product wetting or use in high-humidity area or dew condensation area  
Precision electronic part are used for component parts for this product, so humidity or liquid will cause damage or failure. if it gets wetting, contact the shop where you purchased.
- ★Do not let conductive impurities touch PC Board  
Terminals of PC Board etc are not covered, so conductive impurities (Metal or liquid etc) has danger to cause short circuit easily. Short circuit has possibility to cause failure or fire on battery or wiring.

## Caution

- ★Bring this product out from Japan may required legal process for some country or area.  
Must check on thsi matter.
  
- ★Direct Suport from Kyosho Corporation is only for Japan market. When Customer Support Service is necessary,contact the shop where you purchased if the user is not in Japan.
  
- ★Do not operate at treacherous place  
It will cause falling over by off balance or cause damage or failure by dropping. It also could cause injury to someone by falling.dropping of product.
  
- ★Hold connector ot plug part to pull cable out unless there is any special instruction  
Holding cable parts to pull out may cause shock or fire because of breaking of wire or shirt circuit.

## Charger and Li-Po Battery

This product is using Li-Po Battery for keeping stable high output power. Li-Po Battery has great danger to cause fire or injury if operation is not correct way.

- Use genuine Li-PO Battery Charger (No.HRCH100) and genuine Li-Po Battery (No.HRBA100) for charging and use only for MANOI PFO1 (No.HR100). If items except genuine items or specified genuine items are used, it will be out of gurantee and recycling.

### ●Disposal of damaged/distortional Li-Po Battery

damaged/distortional Li-Po Battery is very dangerous to cause fire or burst. Stop using immidiately and put into salt water a whole night, then insulate battery terminals by tape and bring to the shopwhere you purchased.

### ●Charger and Li-Po Battery

- Do not disassemble or modify charger and Li-Po battery. It will cause leak, heat, fire or burst, and it will be out of gurantee and recycling.
- If following matters happen, stop using immidiately.
  - 1) Smoking
  - 2) Find unnatural smell or sound
  - 3) Water or extraneous material is inside of battery
  - 4) Damage on battery case
- Prepare a bucket of water or asphyxiator in case fire.
- Keep dust, sand away from ferminal part of battery.
- Do not use near combustible material or plastic material which can be deformed by heat
- Do not get a wetting
- If charging is not completed even 80mins is over, and Battery Pack gets heat or is deformed, stop using immidiately and put into salt water a whole night, then insulate battery terminals by tape and bring to the shop where you purchased.



## ●Charger

### Danger

- Charging by no-sole use AC Quick charger is dangerous.
- Do not connect power code, AC Adaptor, each terminals of charger by incorrect way.
- Keep eye on chrarger and battery during charging and do charge at place of no damage even if fire or burst happens. Do not charge near combustibile objects.

### Warning

- Do not charge battery or store battery at high-temperature place such as locations which receive direct sunlight, or inside of car under the scorching sun.
- Use only for charging.
- Do not leave the charger during charging.
- Disconnect cable from AC Power Point when not using charger.
- Check plug and keep clean regularly.

## Li-Po Battery

### Caution

- When Li-PO Battery(including Battery case) gets damaged/deformed, stop using immidiately and put into salt water a whole night, then insulate battery terminals by tape and bring to the shop where you purchased. If keep using damaged/deformed battery, it is very dangerous to cause fire or brust.
- Do not cause short circuit with +terminal and -terminal by metal material etc. Short circuit by both terminal will make the battery bulge out and very dangerous for fire/brust. In case shory circuit happens, it could shorten life of battery.
- Li-Po battery can be bulged when it is used by incorrect way. When it starts bulging out, pull power plug from Power Point and stop charging by manually. Keep charging with bulging is very dangerous to cause fire/brust.

Li-Po battery which once started bulging out may be possible to keep bulging even though stop charging. In that case, move it to safe place such as outside and put into salt water a whole night, then insulate battery terminals by tape and bring to the shop where you purchased.

### Warning

- Keep Li-Po battery away from children and pets.
- When not using Li-Po battery, store it without charging.

 Caution

- Li-Po battery right after used is very hot. Be careful for handling.
- At Cold Place as below 10°C will decrease performance of Li-Po battery and operation time will be shorter.
- Li-Po battery does not have Memory Effect, so it will not cause problem of voltage reduction even if top off charging without full-discharge.
- Keep Li-Po battery at low-humidity place and charging battery in circumstance of 10~30°C can help to make battery life longer.

Any result which is caused by incorrect way as not following instruction will be out of gurantee.

Disclaimer

From judging from the nature of the product, we can not have responsibility on result around user by using this product. Our limitation of gurantee is replacing the product. Use this product under user's responsibility. Specifications are subject to changed without prior notice.

# Included Items

## Actuator KRS-4024SHV

KO Propo's Robot Actuator KRS-4024SHV is tuned for MANOI. maximum operating angle:260degree

Outside Dimension: 43 x 32 x 32.5 (mm)  
Operating Voltage: 9~12V  
Torque:10.5kg/cm\*  
Speed:0.17sec/60\*  
Maximum Operating Angle:about 260degree  
Plastic Gear + Metal gear  
\*as use with NiCd 9cell

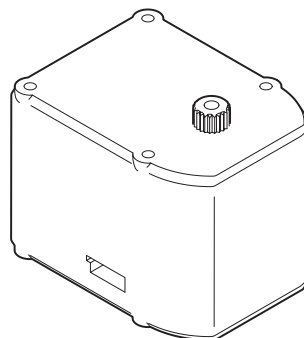

## Control Board RCB-3HV Ver1.03

KO Propo's 24axis control PC Board. Existing PWM signal and Servo Control by Serial signal is possible. Sensors such as gyroscopic can be connect to analog input Port.

Outside Dimension: 35 x 45 x 14.5 (mm)  
Weight:12g  
Operating Voltage: 9~12V  
Output Port: 24  
Input Port: 5(analog3, serial 1+1)

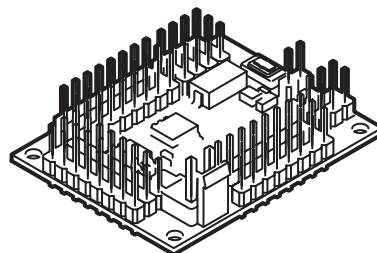

## Gyro-Sensor KRG-3

KO Propo's single axis Gyro-Sensor. It is very simple system as Output gyro-elemental device by electrical pressure.  
Input Terminal which can monitor analog electrical pressure.

Outside Dimension: 22.5 x 12.5 x 7.8 (mm)  
Weight:1.8g  
Operating Voltage: 3~5V  
range of detection:  $\pm 300$  (deg./sec/)

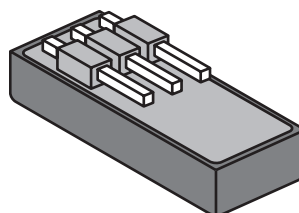



## Charger for Li-Po Battery[No.HRCH100]

Outside Demension: 180 x 140 x 41 (mm)

Weight: approximately 300g

Charging Time: approximately 80mins (approximately 1C/Separate charging each cell)

Charging method : Constant Current Method

Outside case material: ABS(flame resisting grade)

## Li-Po Battery [No.HRBA100] (For 1cell)

Outside Demension: 88 x 37.6 x 11.6 (mm)

Weight: approximately 45g

Voltage: 2.5V(min)/3.7V(typ)/4.2V(max)

Capacity: 1250mAh

Chargable current: 1C

Dis-chargable current: 10C

Protecting circuit method: thermistor (monitoring temperature, current, and voltage by dedicated communication circuit inside as discharging)

Outside case material: ABS

## Icon Indication in Assembling Instruction

In the assembling Instructions, Icons indicate point of hint or notice. Meaning of each Icons are as follows.

### Icons



..... Be careful for too tighten (see page 4)



... Check view for referece of direction of assembling parts



..... point that Cables may be clipped by parts. Be careful



..... Point with very careful



..... Order of assembling



..... Hint for assembling

# Parts List

Item Name	Necessary Numbers	Key No.	Packing No.
Serial USB Adaptor	1	95	Pack 1
Manual, Software & Sample Motion (CD)	1	94	
Extension cable (for Serial USB)	1	112	Pack 2
Li-Po Saver Cover	1	69	
Control Board Cover	1	70	
Front Body Flame	1	66	
Back Body Flame	1	64	
Battery Hatch	1	65	
Connector Cover	1	68	
Servo Lead 90mm (Black)	2	113	
Servo Lead 100mm (Black)	2	77	
Servo Lead 140mm (Black)	2	114	
Servo Lead 150mm (Black)	1	79	
Servo Lead 180mm (Black)	2	80	
Servo Lead 210mm (Black)	2	115	
Servo Lead 240mm (Black)	2	116	
Servo Lead 250mm (Black)	2	117	
Servo Lead 340mm (Black)	2	118	
Servo Lead 360mm (Black)	2	119	
M2.6 × 14 pan-head Tapping Screw	4		
M2 × 8 countersunk Tapping Screw	4		
M2 × 8 pan-head Tapping Screw	6		
Servo CH Label	1	75	
Insulating Tape	1	120	
Shoulder Base	1	13	Pack 3
Arm Base	1	10	
Front Arm Guide	1	11	
Rear Arm Guide	1	12	
Front Arm Flame	1	5	
Rear Arm Flame	1	6	
Arm Side Cover	1	7	
Arm Cover	2	14	
Arm Screw Cover	2	15	
Arm Joint	2	2	
Front Arm Plate	1	3	
Rear Arm Plate	1	4	
Front Hand (Right)	1	8	
Rear Hand (Right)	1	9	
Hand Cap	2	16	
Knuckle (right)	1	17	
M2 × 5 pan-head Tapping Screw	8		
M2 × 6 pan-head Machine Screw	4		
M2 × 10 pan-head Tapping Screw	16		
M2 × 16 pan-head Machine Screw	8		
M2 × 20 pan-head Machine Screw	4		
M2 Nut 2types	4		
M3 × 8 Bind Tapping Screw	3		

安全のための  
注意事項

付属製品に  
ついて

組み立て

ソフトウェア  
の設定

MANO-  
遊び方

での  
オプションパー  
ツの取り付け

故障かなと  
思ったら

ユーザー相談  
室のご案内

用語集

パーツ販売  
リスト

展開図

Item Name	Necessary Numbers	Key No.	Packing No.
M2.6 × 10 countersunk Tapping Screw	4		Pack 3
M2.6 × 10 pan-head Tapping Screw	3		
Low Height Servo Horn	2	73	
Shoulder base	1	13	Pack 4
Arm Base	1	10	
Front Arm Guide	1	11	
Rear Arm Guide	1	12	
Front Arm Flame	1	5	
Rear Arm Flame	1	6	
Arm Side Cover	1	7	
Arm Cover	2	14	
Arm Screw Cover	2	15	
Arm Joint	2	2	
Front Arm Plate	1	3	
Rear Arm Plate	1	4	
Front Hand (Left)	1	18	
Rear Hand (Left)	1	19	
Hand Cap	2	16	
Knuckle (Left)	1	20	
M2 × 5 countersunk Tapping Screw	8		
M2 × 6 pan-head Machine Screw	4		
M2 × 10 countersunk Tapping Screw	16		
M2 × 16 countersunk Machine Screw	8		
M2 × 20 countersunk Machine Screw	4		
M2 Nut (2types)	4		
M3 × 8 bind Tapping Screw	3		
M2.6 × 10 countersunk Tapping Screw	4		
M2.6 × 10 pan-head Tapping Screw	3		
Low height Servo Horn	2	73	
Side Ankle	1	22	
Thigh Flame	1	32	
Front Hip Flame (Right)	1	36	
Rear Hip Flame (Right)	1	39	
Inside Hip Flame	1	37	
Outside Hip Flame	1	38	
Side Hip Cover	1	40	
Front Thigh Cover (Right)	1	34	
Rear Thigh Cover (Right)	1	35	
Outside Knee (Right)	1	29	
Knee Cover (Right)	1	30	
Inside Knee (Right)	1	33	
Knee Stay	1	31	
Front Ankle (Right)	1	23	
Middle Ankle	1	21	
Rear Ankle	1	24	
Rear Ankle Joint (Right)	1	25	
Front Ankle Joint (Right)	1	26	
Shoe (right)	1	27	
Sole (Right)	1	28	
Ankle Cap	1	41	



Item Name	Necessary Numbers	Key No.	Packing No.
M2 × 5 countersunk Tapping Screw	14		Pack 5
M2 × 5 pan-head Tapping Screw	12		
M2 × 8 pan-head Tapping Screw	10		
M2 × 10 countersunk Tapping Screw	16		
M2 × 16 countersunk Machine Screw	18		
M3 × 8 bind Tapping Screw	4		
M2.6 × 8 pan-head Tapping Screw	2		
M2.6 × 10 countersunk Tapping Screw	8		
Low Hight Servo Horn	5	73	Pack 6
Side Ankle	1	22	
Thigh Flame	1	32	
Front Hip Flame (Left)	1	52	
Rear Hip Flame (Left)	1	53	
Inside Hip Flame	1	37	
Outside Hip Flame	1	38	
Side Hip Cover	1	40	
Front Thigh Cover (Left)	1	50	
Rear Thigh Cover (Left)	1	51	
Outside Knee (Left)	1	47	
Knee Cover (Left)	1	48	
Inside Knee (Left)	1	49	
Knee Stay	1	31	
Front Ankle (Left)	1	42	
Middle Ankle	1	21	
Rear Ankle	1	24	
Rear Ankle Joint (Left)	1	43	
Front Ankle Joint (Left)	1	44	
Shoe (Left)	1	45	
Sole (Left)	1	46	
Ankle Cap	1	41	
M2 × 5 countersunk Tapping Screw	14		
M2 × 5 pan-head Tapping Screw	12		
M2 × 8 pan-head Tapping Screw	10		
M2 × 10 countersunk Tapping Screw	16		
M2 × 16 countersunk Machine Screw	18		
M3 × 8 bind Tapping Screw	4		
M2.6 × 8 pan-head Tapping Screw	2		
M2.6 × 10 countersunk Tapping Screw	8		
Low Height Servo Horn	5	73	
Neck Support	1	54	
Face	1	60	
Back Head	1	61	
Neck Base	1	55	
Back Head Cap	1	63	
Head Base	1	56	
Visor	1	62	
Eye Base	2	57	
Eye	2	58	
Pupil	2	59	
M2 × 8 countersunk Tapping Screw	4		

安全のための  
注意事項

付属製品に  
ついて

組み立て

ソフトウェア  
の設定

MANO-1  
遊び方

オプションパー  
ツの取り付け

故障かなと  
思ったら

ユーザー相談  
室のご案内

用語集

パーツ販売  
リスト

展開図

Item Name	Necessary Numbers	Key No.	Packing No.
M2 × 20 countersunk Machine Screw	2		Pack 7
M3 × 8 bind Tapping Screw	1		
M2.6 × 10 pan-head Tapping Screw	6		
Low Height Servo Horn	1	73	
Front Cowl	1	72	Pack 8
Back Cowl	1	71	
M2 × 5 countersunk Tapping Screw	8		
M3 × 8 pan-head Tapping Screw	2		
M2.6 × 8 pan-head Tapping Screw	4		Pack 9
PF Logo Stiker	1	96	
Silicon Grease	1	74	
Gyro-Sensor Unit (KRG-3)	2	86	Pack10
M2.6 × 14 pan-head Tapping Screw(for spare)	2		
M2.6 × 10 pan-head Tapping Screw(for spare)	3		
M2.6 × 8 pan-head Tapping Screw(for spare)	2		
M2.6 × 10 countersunk Tapping Screw(for spare)	6		
M2 Nut 2types(for spare)	2		
M2 × 8 pan-head Tapping Screw(for spare)	6		
M2 × 5 pan-head Tapping Screw) (for spare)	4		
M2 × 6 pan-head Machine Screw(for spare)	4		
M2 × 10 countersunk Tapping Screw(for spare)	14		
M2 × 20 countersunk Machine Screw(for spare)	2		
M2 × 16 countersunk Machine Screw(for spare)	10		
M2 × 5 countersunk Tapping Screw(for spare)	10		
M2 × 8 countersunk Tapping Screw(for spare)	2		
M3 × 8 bind Tapping Screw(for spare)	3		
Servo Motor (KRS-4024SHV)	17	1	Pack11
Li-Po Savor	1	88	Pack12
Switch	1	90	
Control Board (RCB-3)	1	85	
Battery Connector Unit	1	87	
Connector Label	1	111	
Side Leg Chekcing Tool	1	121	Pack13
Rear Leg Checking Tool	1	122	
Under Leg Checking Tool	1	123	
Upper Arm Checking Tool	1	124	
Bottom Arm Checking Tool	1	125	
Li-Po Battery (1250mAh)	3	93	
Li-Po AC Chager for MANOI	1	91	
AC Adaptor	1	92	
Instruction Manual (Booklet)	1		
Greeting Letter from Suzuki Chairman	1		
Full Size Drawing Sheet for Screws	1		
Full Size Drawing Sheet for Servo Leads	1		
MANOI Advisory	1		
User's Post Card	1		

# Parts Views

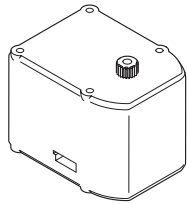

[1] Servo Motor



[73] Low Height Servo Horn

## Arms

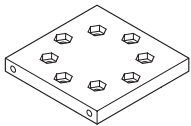

[2] Arm Joint

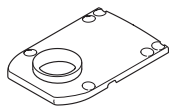

[4] Rear Arm Plate

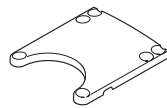

[3] Front Arm Plate

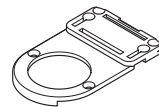

[5] Front Arm Flame

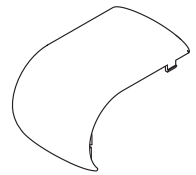

[7] Front Side Cover

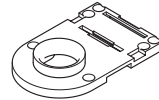

[6] Rear Arm Flame



[16] Hand Cap

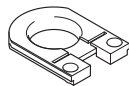

[12] Rear Arm Guide

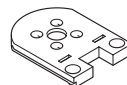

[11] Front Arm Guide

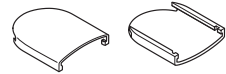

[14] Arm Cover



[15] Arm Screw Cover

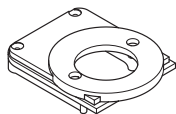

[13] Shoulder Base

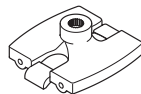

[10] Arm Base

[8] Front Hand(Right)

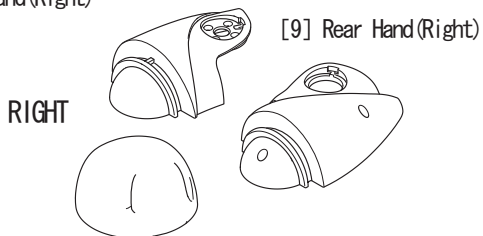

[17] Knuckle(Right)

[18] Front Hand(Left)

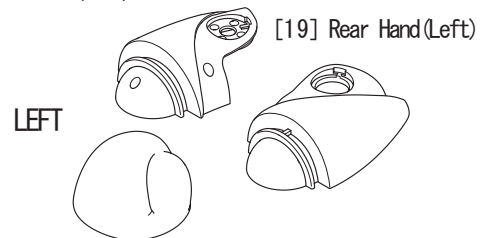

[20] Knuckle(Left)

※Arm Parts without mentioned of (Right) or (Left) is common parts for Right and Left.

## Right Leg

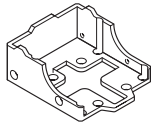

[21] Middle Ankle

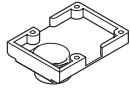

[22] Side Ankle

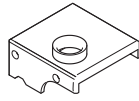

[23] Front Ankle  
(Right)

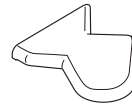

[26] Front Ankle  
Joint (Right)

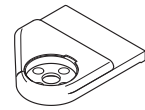

[25] Rear Ankle  
Joint (Right)

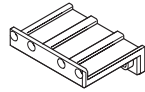

[24] Rear Ankle

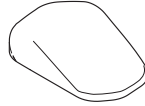

[30] Knee Cover (Right)

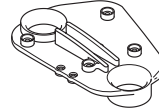

[29] Outside Knee [ 31] Knee Stay  
(Right)

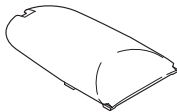
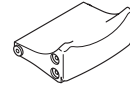

[40] Side Hip Cover

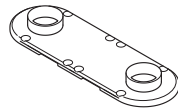

[32] Thigh Flame

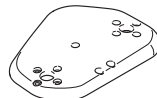

[33] Inside Knee  
(Right)

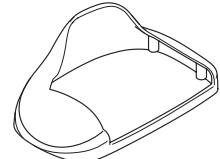

[27] Shoe (Right)

[34]  
Front Thigh Cover  
(Right)

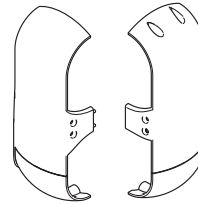

[35]  
Rear Thigh Cover  
(Right)

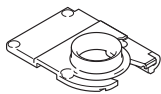

[36]  
Front Hip Flame  
(Right)

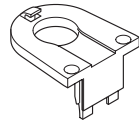

[38]  
Outside Hip Flame

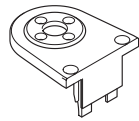

[37]  
Inside Hip Flame

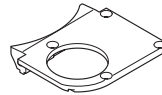

[39]  
Rear Hip Flame  
(Right)



[41]  
Ankle Cap

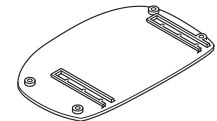

[28]  
Sole (Right)

## Left Leg

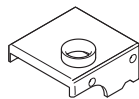

[42] Front Ankle  
(Left)



[44] Front Ankle  
Joint (Left)

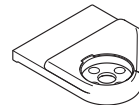

[43] Rear Ankle  
Joint (Left)

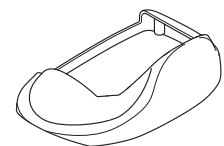

[45] Shoe (Left)



[48] Knee Cover (Left)

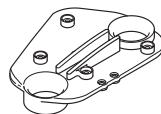

[47] Outside Knee  
(Left)

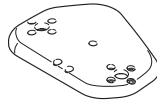

[49]  
Inside Knee  
(Left)

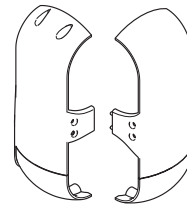

[50]  
Front Thigh Cover  
(Left)

[51]  
Rear Thigh Cover  
(Left)

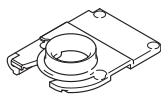

[52] Front Hip Flame  
(Left)

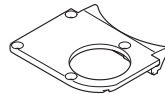

[53] Rear Hip Flame  
(Left)

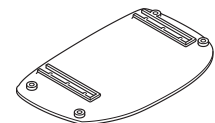

[46] Sole (Left)

※Leg Parts without mentioned of (Left) or (Right) is common parts for Left and Right.

Head

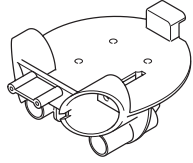

[56] Head base



[54] Neck Support



[62] Visor



[63] Back Head Cap

[57] Eye Base



[58] Eye



[59] Pupil

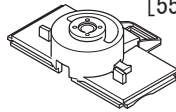

[55] Neck base

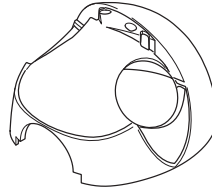

[60] Face

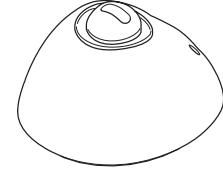

[61] Back Head

Body

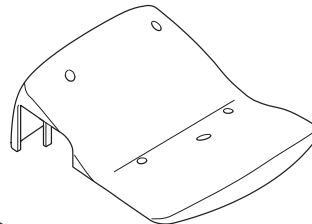

[71] Back Cowl

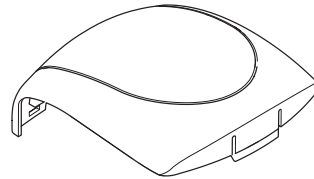

[72] Front Cowl

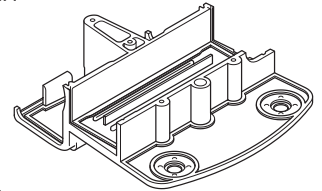

[64] Back Body Flame

[70] Control Board Cover

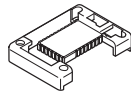

[90] Switch

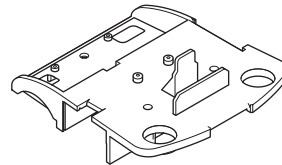

[66] Front Body Flame

[68] Connector Cover

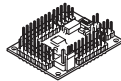
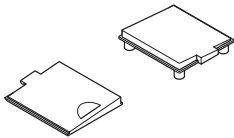

[85] Control Board (RCB-3)



[69] Li-Po Savor Cover

[65] Battery Hatch

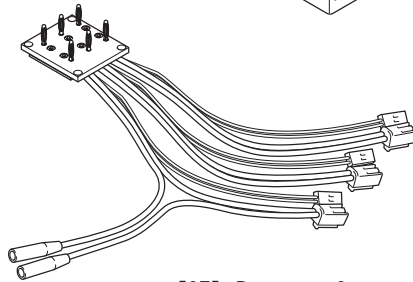

[87] Battery Connector Unit

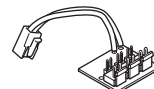

[88] Li-Po Savor



[74] Silicon Grease

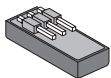

[86] Gyro-Sensor Unit (KRG-3)

# Assembling

## 工程 01 Preparation of Assembling

New Parts for this step

- [91] Charger for Li-Po Battery x 1
- [92] AC Adaptor for the charger  
Power Code x 1
- [93] Li-Po Battery x 3
- [95] Serial USB Adaptor x 1  
accessory CD-ROM x 1



### 1-1 Charging Battery

To charge Li-Po battery, use combination of charger for Li-Po Battery [No.HRCH100] and Li-Po Battery[No.HRBA100]. Also use only AC Adaptor [No.HRCH101] for the charger.

Charging single Li-Po battery pack is okay, but use all of 3sells of Li-Po battery to operation of MANOI PF01. Also, do not use Li-Po battery packs as only one pack is full-charged and others are not full-charged. Li-Po Battery can accept top off charging, so it is not necessary to do dis-charging.  
Please, read instrction manual of Charger for Li-Po Battery{No.HRCH100} also.

#### Charging Method



- ① Connect Power Code to AC Adaptor.

#### アイコン解説



注意



ポイント



締め込み注意



{@ 方向注意



組み立て順番



挟み込み注意





② Connect AC Adaptor with the charger.



③ Plug power plug to power point.



④ Insert battery pack into charger



Insert Battery pack until it reached innermost as chase of battery pack follows guide of charger



MANO1 logo should faces upside when battery pack is inserted into the charger.

アイコン解説



注意



ポイント



締め込み注意



方向注意

組み立て順番



挟み込み注意



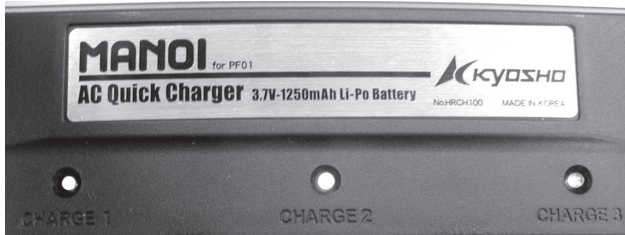

⑤ Make sure LED has Green light on.

⚠ When Li-PO Battery has smoking or strange smell or getting bulge, stop using immediately and put into salt water a whole night, then insulate battery terminals by tape and bring to the shop where you purchased.

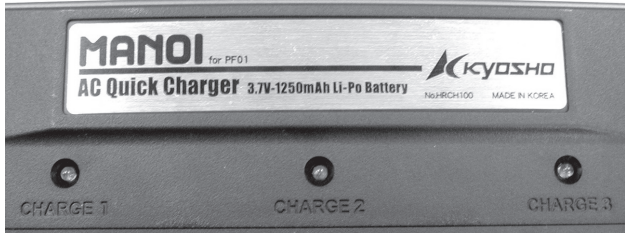

⑥ When LED lights off or blink on and off (around 80mins), charging is done.

⚠ If charging is not completed after 80mins and battery pack has heat or deforming, stop using immediately and put into salt water a whole night, then insulate battery terminals by tape and bring to the shop where you purchased.

⑦ Remove battery pack from the charger and unplug power plug from AC Power Point.

⚠ Do not leave Li-Po battery being inserted into charger for long time.

#### アイコン解説



注意



ポイント



締め込み注意

< { @ 方向注意

^ 組み立て順番



挟み込み注意

## 1-2 Installation of HeartToHeart3



HeratToHerat3 which is included with this product is for Control Board RCB-3 Ver.03, and not for operation of old RCB-3. Also, Control Board RCB-3 Ver.03 is not for control of old HeratToHeart3. Even if old RCB-3 and old HeartToherat3 in your hand already, install HertToHerat3 which is with this product again.

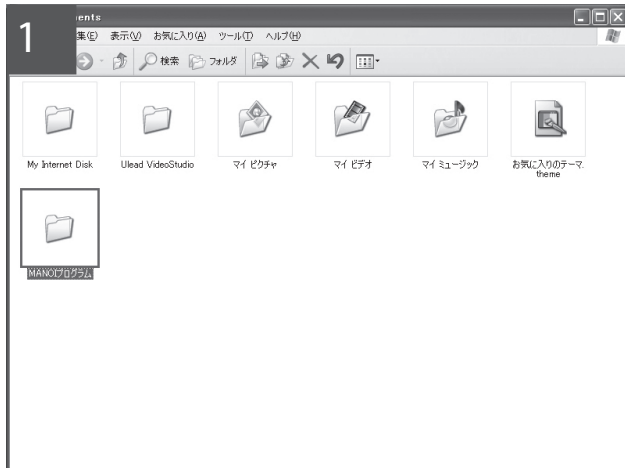

Create new folder at any place of HDD of PC (ex. My Documents) and name it(ex. MANO1 Program).



It is certainly necessary to create new folder.

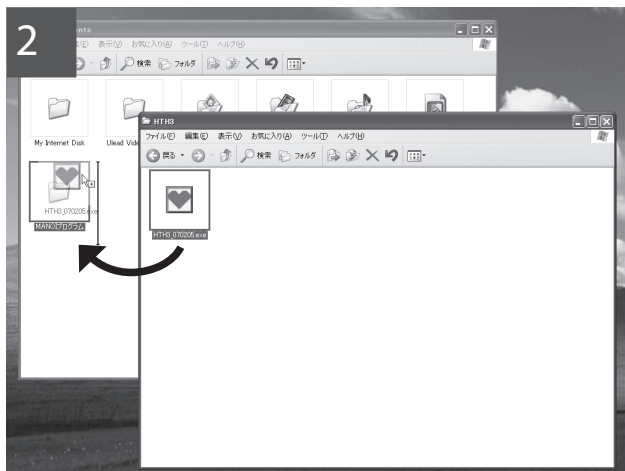

Insert appurtenant CD-ROM into PC which will be used for setting of MANO1 PF01. Make copy of "HTH3\_0 7020 5.exe" in loaded drive(x:¥) on new folder which was created in above step 1 by Drag & Drop.



"x" will be different by PC which is used.

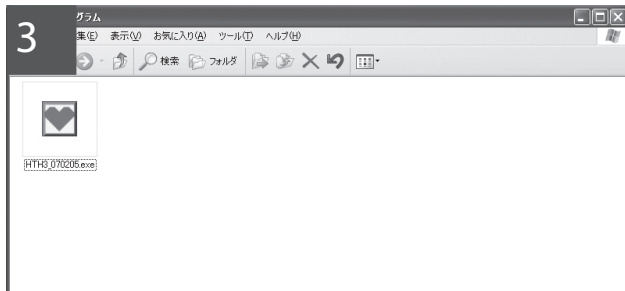

When "HTH3\_070205.exe" is displayed in the folder which was created in above step 1, installation is completed.



Keep CD-ROM inside of PC and move to next process of Installation of 1-3 Serial USB Adaptor Driver.

### アイコン解説



注意



ポイント



締め込み注意



方向注意

組み立て順番



挟み込み注意

# 1-3 Installation of Serial USB Adaptor Driver

\*Instruct instillation to Windows XP here.

⚠ Windows2000 has slight different way of instillation.

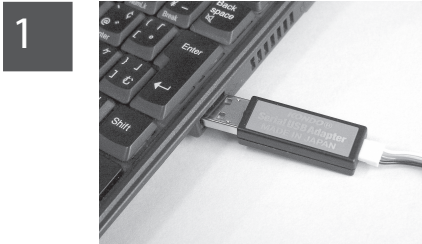

Insert Serial USB Adaptor into USB Port which will be used for MANOI.



Serial USB Adaptor is in Pack 1



Insert into USB Ports of PC directly



It is recommended to use same port for Serial USB Adaptor insert. If insert to another port, installation of driver will be done again.

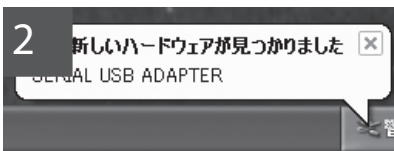

A window of 「新しいハードウェアの検出ウィザード」 [detection wizard of new hardware] will be opened.

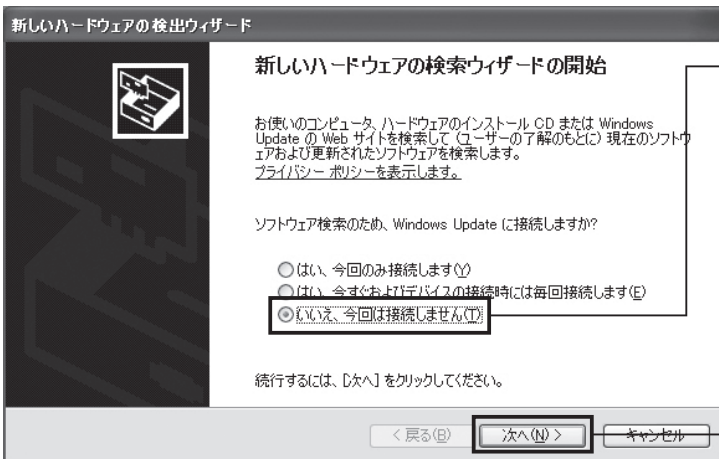

① Choose

[いいえ、今回は接続しません]  
[No, not connect this time]

② Click [次へ] [Next]



When your PC is not connected with Internet, views of left will not be displayed. Just move to next step.

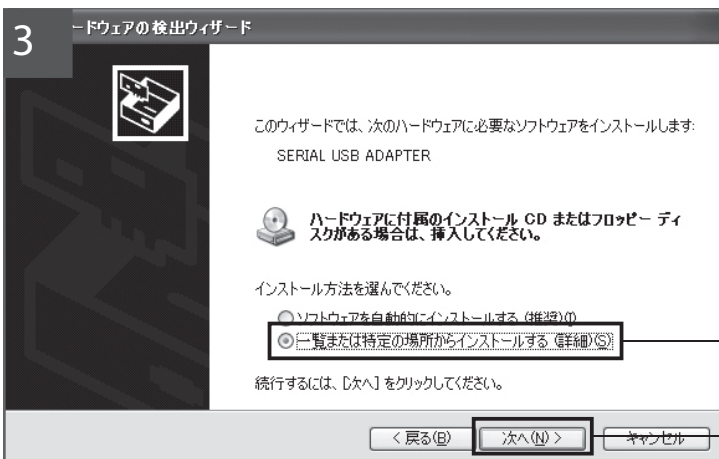

④ Choose

[一覧または特定の場所からインストールする]  
Install from list or certain place]

⑤ Click [次へ] [Next]

## アイコン解説



注意



ポイント



締め込み注意

<{@ 顎 方向注意

^ 組み立て順番



挟み込み注意

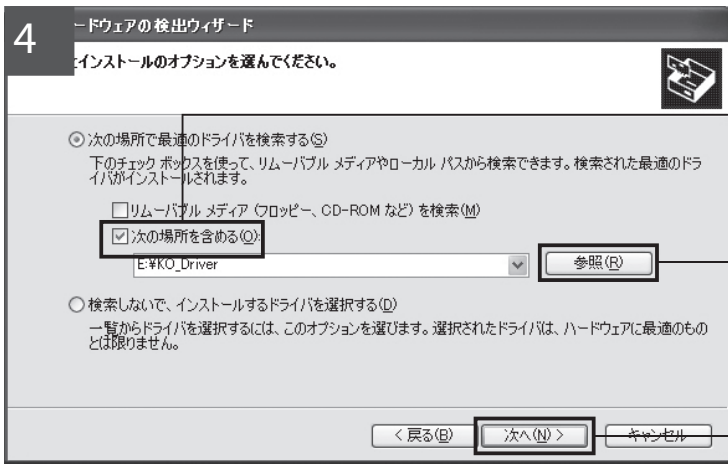

① Check on  
[次の場所を含める]  
[Include next place]

② Click [参照][reference]

💡 Choose [KO\_Driver] in CD-ROM

② Click [次へ] [Next]



💡 If 「ディスクの挿入」 [Insert disc] or 「ファイルが必要」 [Need file] is displayed as different from left view, follow below instructions.

- ① When 「ディスクの挿入」 [Insert Disc] is displayed, click [OK].
- ② When 「ファイルが必要」 [Need file] is displayed, click 「参照」 [Reference] and click [KO\_Driver] in attached CD-ROM, then click [ftdibus.sys] and click [Open]

After themn, follow instruction which is displayed and instruction in this manual to instal.

Click [続行] [Continue].

💡 After Click「続行」 [Continue], Instillation will start.

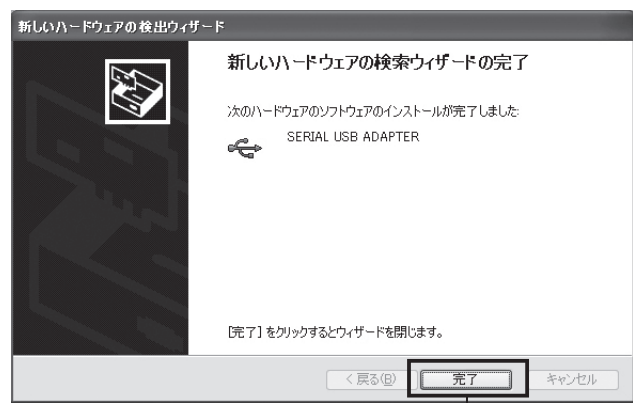

💡 「新しいハードウェアの検出ウィザード」 [detection wizard of new hardware] will be opened for instillation of another driver.

Click [完了] [End]

アイコン解説

注意
 ポイント
 締め込み注意
 方向注意
 組み立て順番
 挟み込み注意

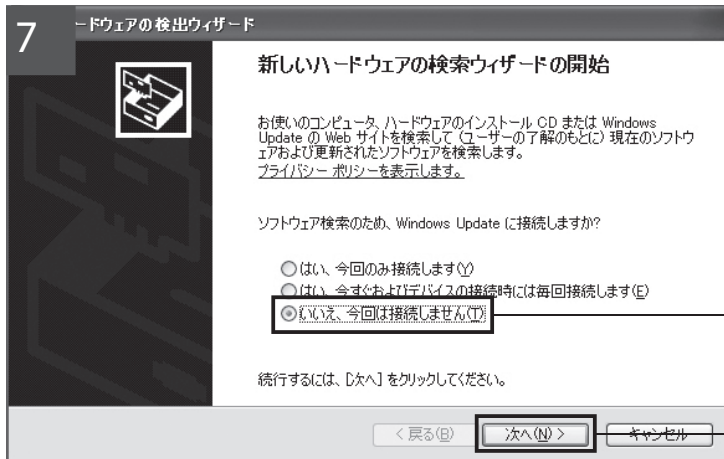

When your PC is not connected with Internet, views of left will not show up. Just move to next step.

- ① Choose  
[いいえ、今回は接続しません]  
[No, not connect this time]

- ② Click [次へ] [Next]

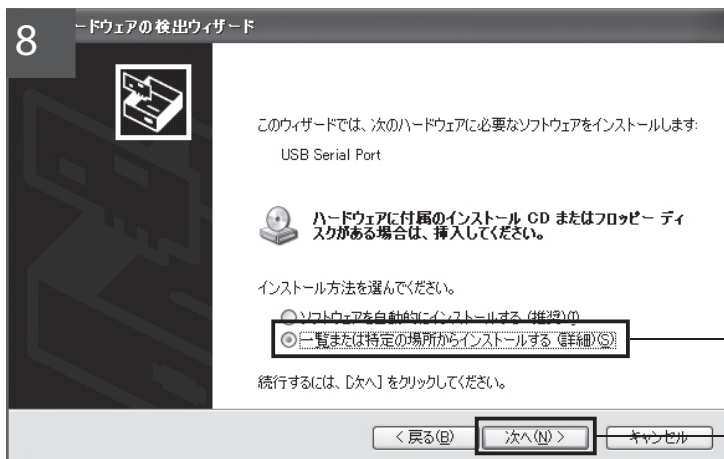

- ① Choose  
[一覧または特定の場所からインストールする]  
[Install from list or certain place]

- ② Click [次へ] [Next]

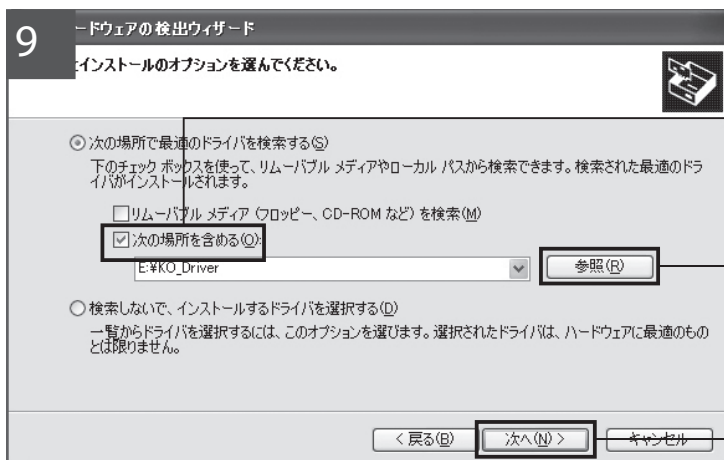

- ① Check on  
[次の場所を含める]  
[Include next place]

- ② Click [参照] [reference]



Choose [KO\_Driver] in CD-ROM

- ③ Click [次へ] [Next]

## アイコン解説



注意



ポイント



締め込み注意



< [ @ 顎 ] 方向注意



組み立て順番



挟み込み注意



💡 If 「ディスクの挿入」 [Insert disc] or 「ファイルが必要」 [Need file] is displayed as different from left view, follow below instructions.

- ① When 「ディスクの挿入」 [Insert Disc] is showed up, click [OK].
- ② When 「ファイルが必要」 [Need file] is displayed, click 「参照」 [Reference] and click [KO\_Driver] in attached CD-ROM, then click [ftdibus.sys] and click [Open]

After themn, follow instruction which is displayed and instruction in this manual to instal.

Click [続行] [Continue].

💡 After Click「続行」 [Continue], Instillation will start.



Click [完了] [End]

アイコン解説

注意
 ポイント
 締め込み注意
 方向注意
 組み立て順番
 挟み込み注意



## 1-4 Check setting of COM port

1

Move as 「スタート」 [Start] → 「コントロールパネル」 [Control panel] → 「パフォーマンスとメンテナンス」 [Performance and maintenance] → 「システム」 [System], and click tab of 「ハードウェア」 ( 「パフォーマンスとメンテナンス」 [Performance and maintenance] may not be displayed depending on PC type)

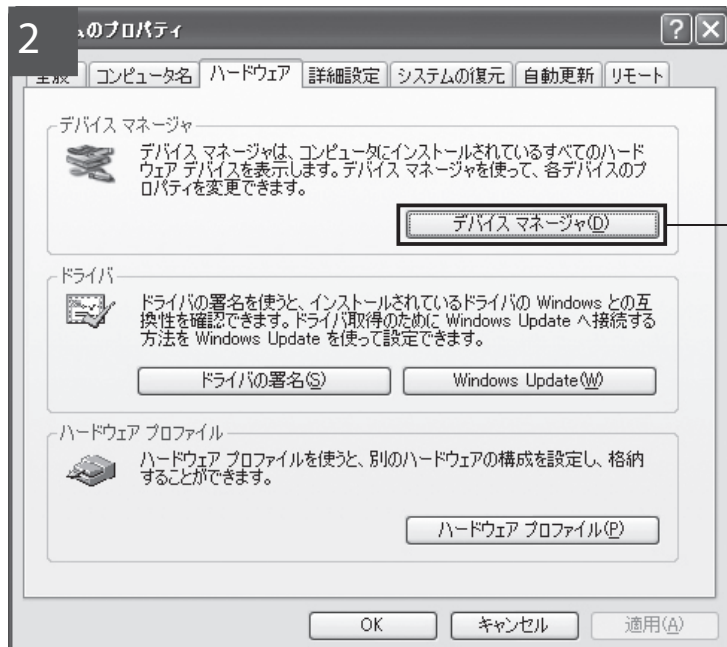

Click 「デバイスマネージャ」 [Device Manager]

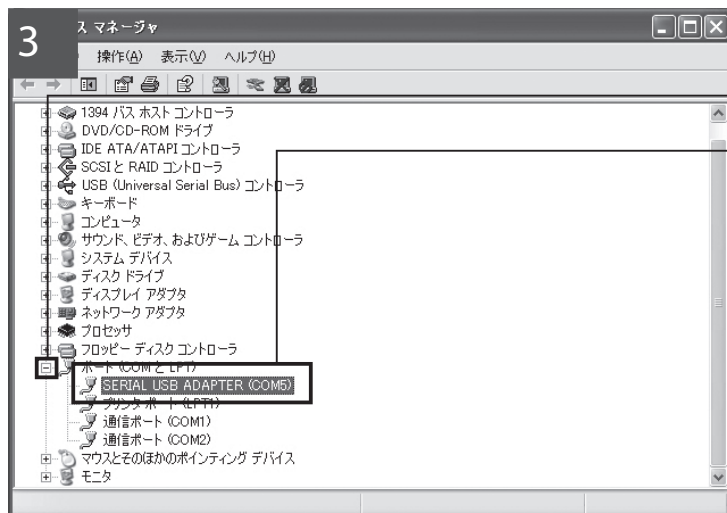

Click [+] of 「ポート」 [Port].

If there is [SERIAL USB ADAPTER (COM "X")] in opened list, installation is completed.

Lightbulb icon: "X" part will be used for setting of HeratToHerat3 in operation 2-5, so write down and keep it.

Lightbulb icon: In example view, "X" part is "5", but it will depend on your PC or USB port of inserting, so check at your PC.

Lightbulb icon: If there is no [SERIAL USB ADAPTER (COM "X")] displayed, it is necessary to do operation 1-3 again.

### アイコン解説



注意



ポイント



締め込み注意

< { @ 顎 方向注意

^ 組み立て順番



挟み込み注意



# 工程 02 Setting Neutral Position of Servo Motor (Pack2, 11, 12)

 This process should be started after Operation 1 and charging battery are done.

- \* "Control Board" and "Li-Po Savor" which are used in this operation are precision electric part. When conductance object touches uncovered terminals, it is possible to cause damage, failure, or fire. Be careful and make sure operation area is safe, then take these parts out.
- \* "Control Board" and "Li-Po Savor" which are used in this operation are easily affected by static electricity. Do not operate this process with/near by Nylon shirts, table cross, plastic material which can cause static electricity

 From this process, work of tighten the screws will start. If head of screws are messed, use spare screws in Pack 10, or purchase new set of screws in Parts Sales list.

## 2-1 Assembling of Li-Po Savor and Battery Terminal Board Unit

Parts/Units from previous operation/step

None

New Prats for this step

[66] Front Body Flame

[68] Connector Cover

[69] Li-Po Savor Cover

[87] Battery Connector Unit

[88] Li-Po Savor

[90] Switch

[111] Connector Label

M2 x 8 countersunk Tapping Screw x 4  
M2 x 8 pan-head Tapping Screw x 2

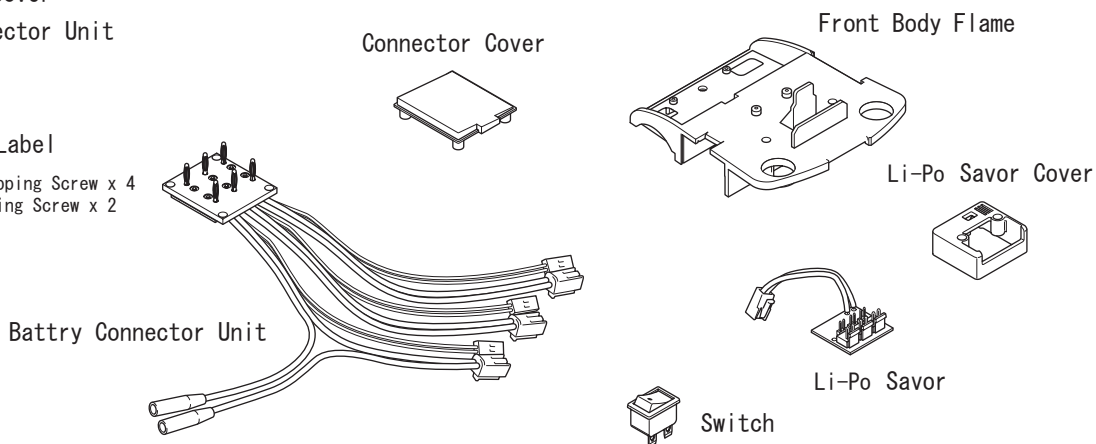

1

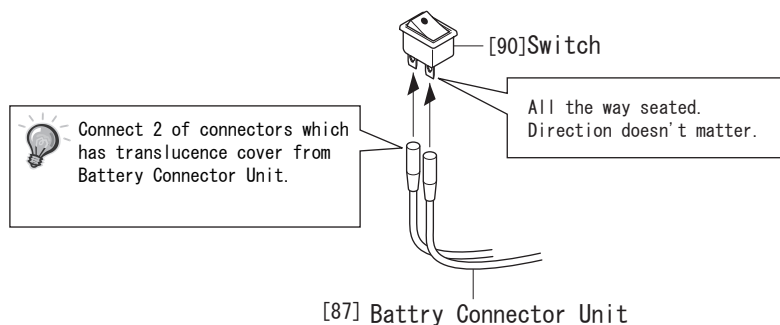

アイコン解説



注意



ポイント



締め込み注意



< @ 方向注意

^ 組み立て順番



挟み込み注意

## 2

\*Follow numbers for assembling order

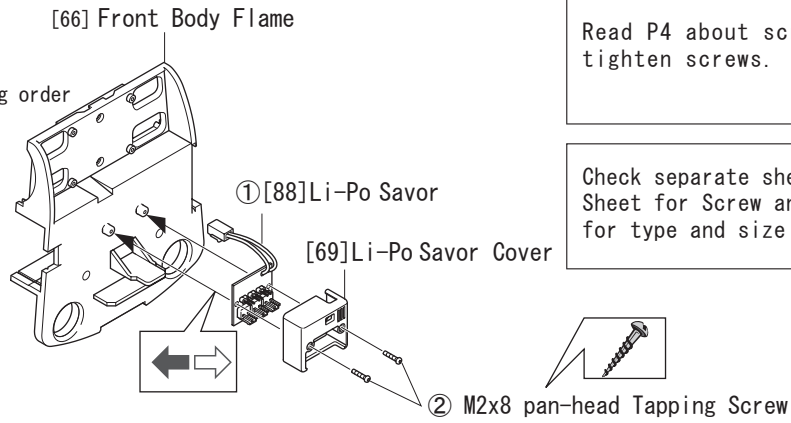

Read P4 about screws before tighten screws.

Check separate sheet of "Check Sheet for Screw and Nut Shape" for type and size of Screws.

## 3

\*Follow numbers for assembling order

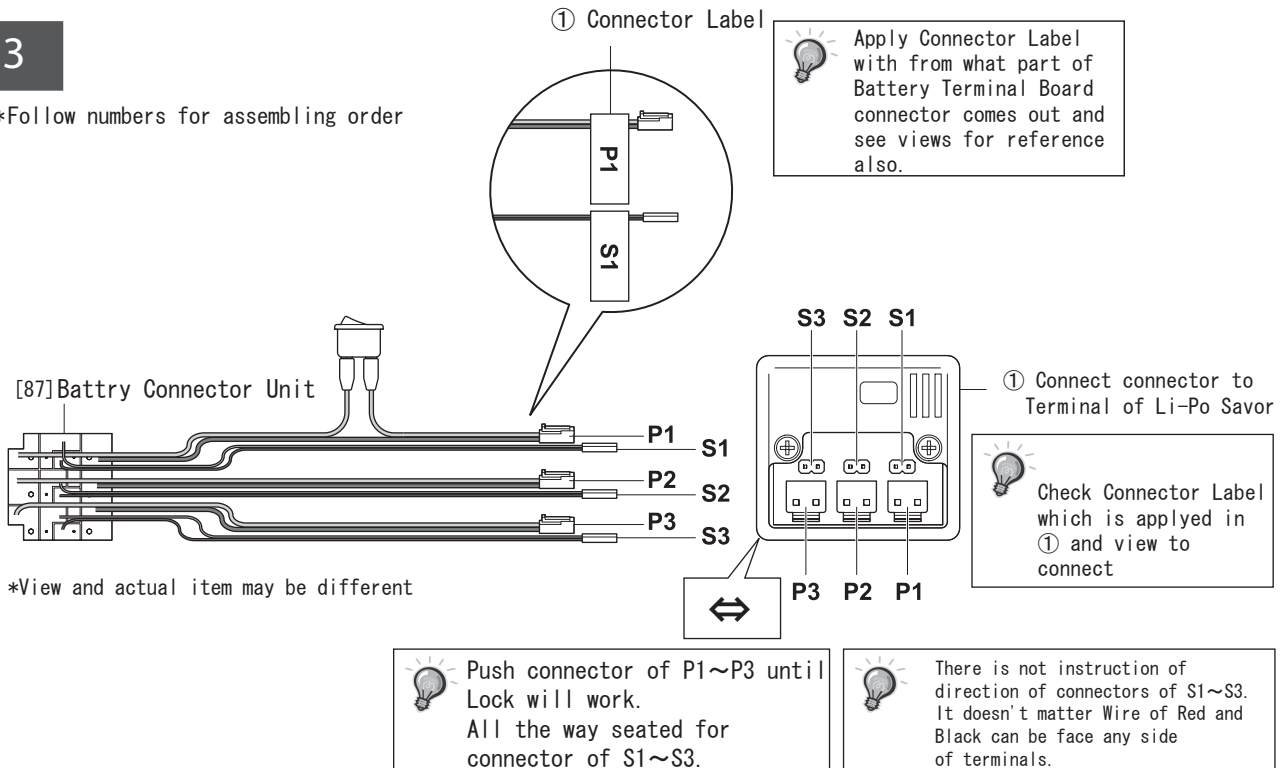

\*View and actual item may be different

## 4

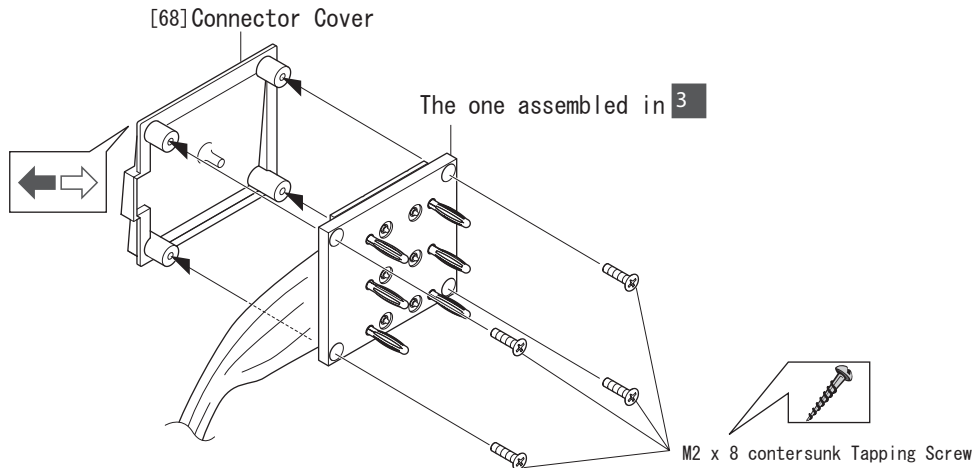

### アイコン解説



注意



ポイント



締め込み注意

< { @ 寄 方向注意

^ 組み立て順番



挟み込み注意

## 2-2 temporarily Assembling of Body Flame

For safe operation, assemble Body Flame temporary

Parts/Units from previous operation/step

Battery Terminal Board Unit (→ 2-1)

Front Body Flame Unit (→ 2-1)

New Prats for this step

- [64] Back Body Flame
- [70] Control Board Cover
- [85] Control Board (RCB-3HV Ver1.03)
- [120] Insulating Tape
- M2 x 8 pan-head Tapping Screw x 4
- M2.6 x 14 pan-head Tapping Screw x 4

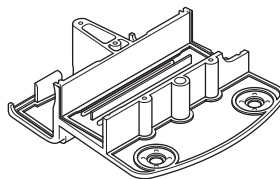

Back Body Flame

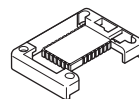

Control Board Cover

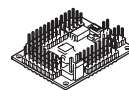

Control Board  
(PCB-3)

1

[64]Back Body Flame

\*Follow numbers for assembling Order

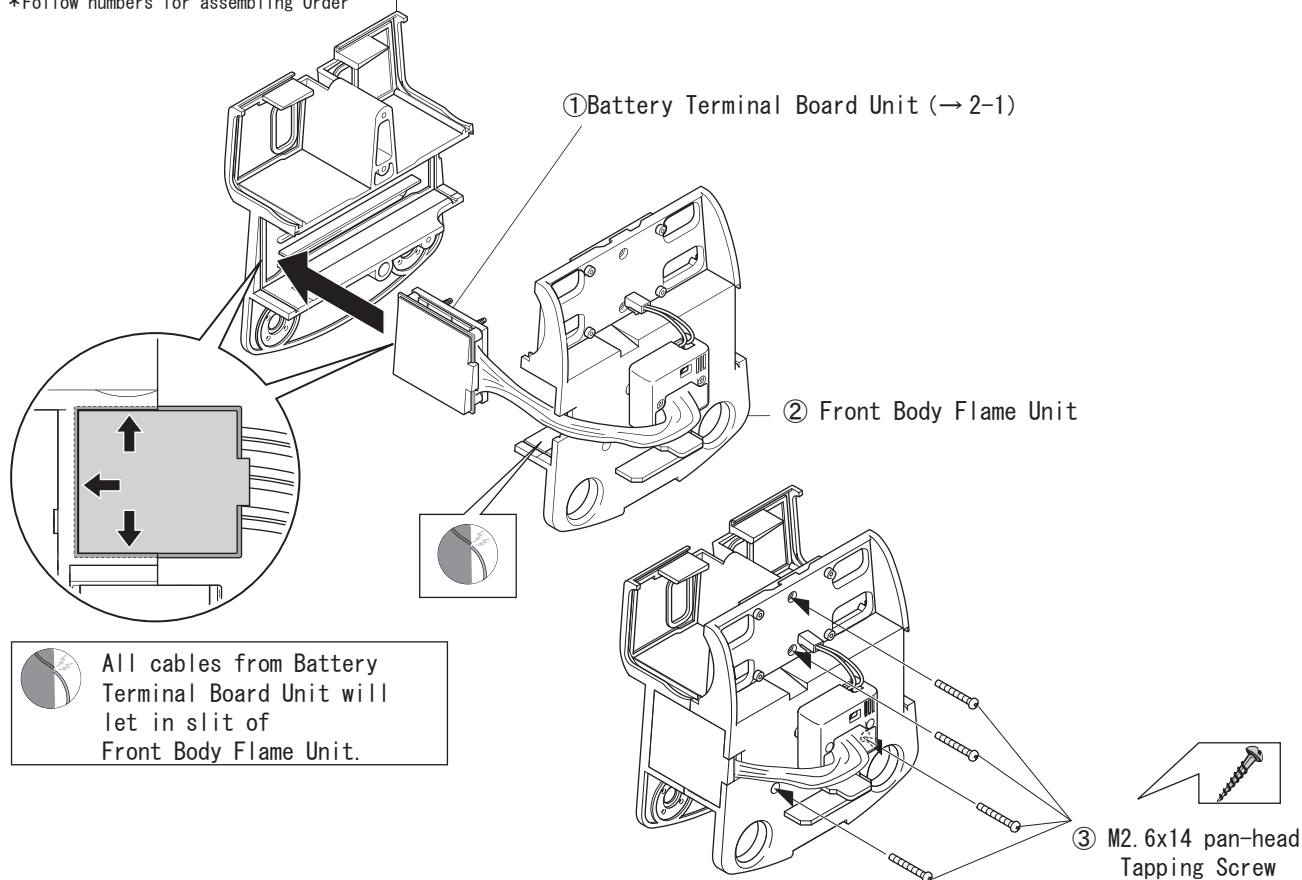

### アイコン解説



注意



ポイント



締め込み注意



方向注意

組み立て順番



挟み込み注意

2

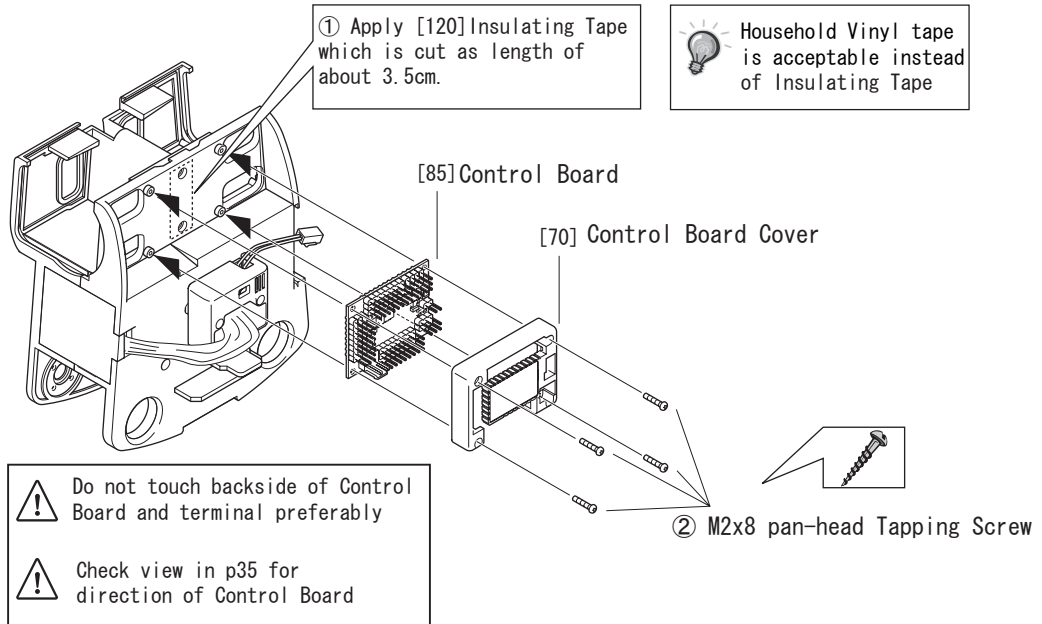

3

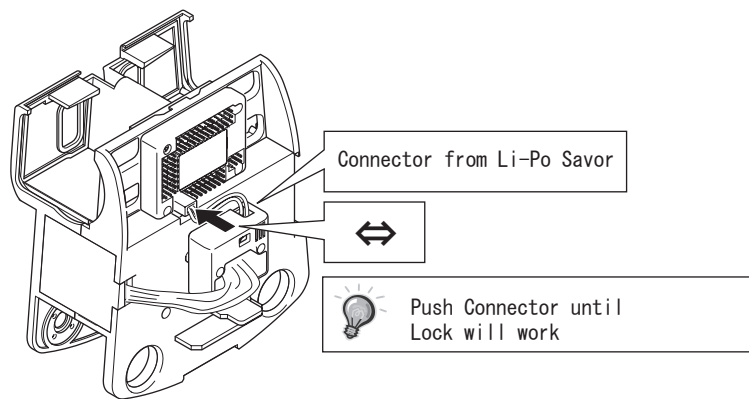

アイコン解説



注意



ポイント



締め込み注意

<{@各方向注意

^ 組み立て順番



挟み込み注意

## 2-3 Assembling of Servo Motor and Wiring

Parts/Units from previous operation/step

None

New Parts for this step

- |                              |                              |
|------------------------------|------------------------------|
| [1] Servo Motor x 17         | [119] Servo Lead (360mm) x 2 |
| [113] Servo Lead (90mm) x 2  | [75] Servo CH Label          |
| [114] Servo Lead (140mm) x 2 |                              |
| [79] Servo Lead (150mm) x 1  |                              |
| [80] Servo Lead (180mm) x 2  |                              |
| [115] Servo Lead (210mm) x 2 |                              |
| [116] Servo Lead (240mm) x 2 |                              |
| [117] Servo Lead (250mm) x 2 |                              |
| [118] Servo Lead (340mm) x 2 |                              |

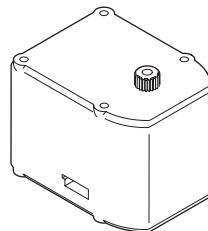

Servo Motor

1

Apply Servo CH Label to Servo Lead as below instruction.

Check "Check Sheet for Servo Lead Length" for length of Servo Lead (120mm~230mm)

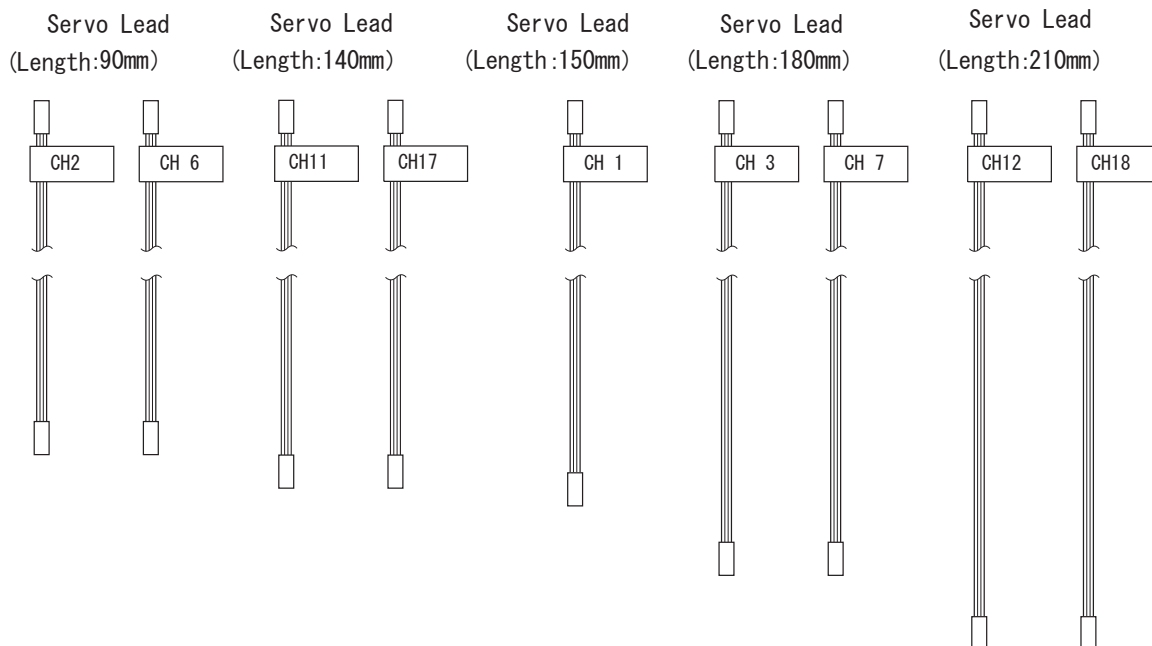

Servo Lead (100mm) will be used in OperationS4 "Setting of Gyro Sensor", so keep it.

### アイコン解説



注意



ポイント



締め込み注意



← 方向注意

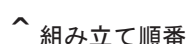

組み立て順番



挟み込み注意

Servo Lead  
(Length:240mm)

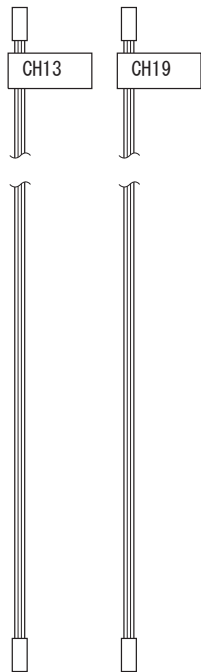

Servo Lead  
(Length:250mm)

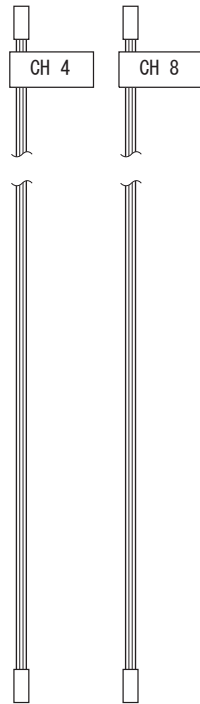

Servo Lead  
(Length:340mm)

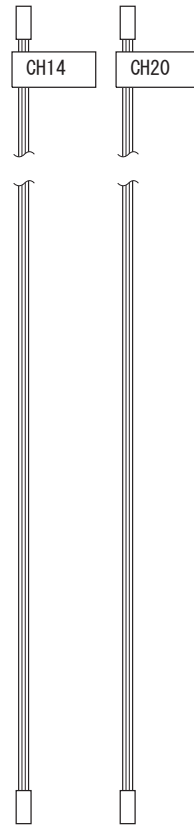

Servo Lead  
(Length:360mm)

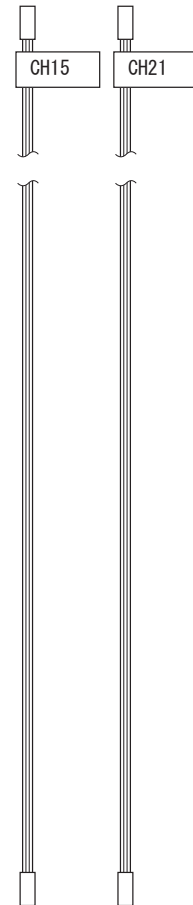

2

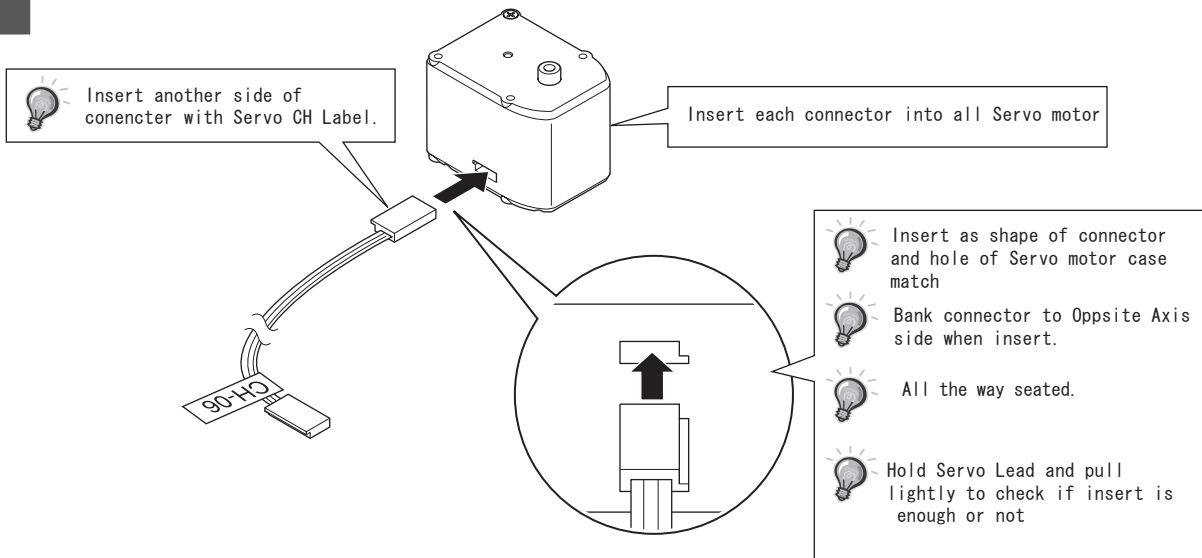

アイコン解説



注意



ポイント



締め込み注意

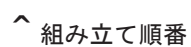

挟み込み注意

3

Remove assignment countersunk screws

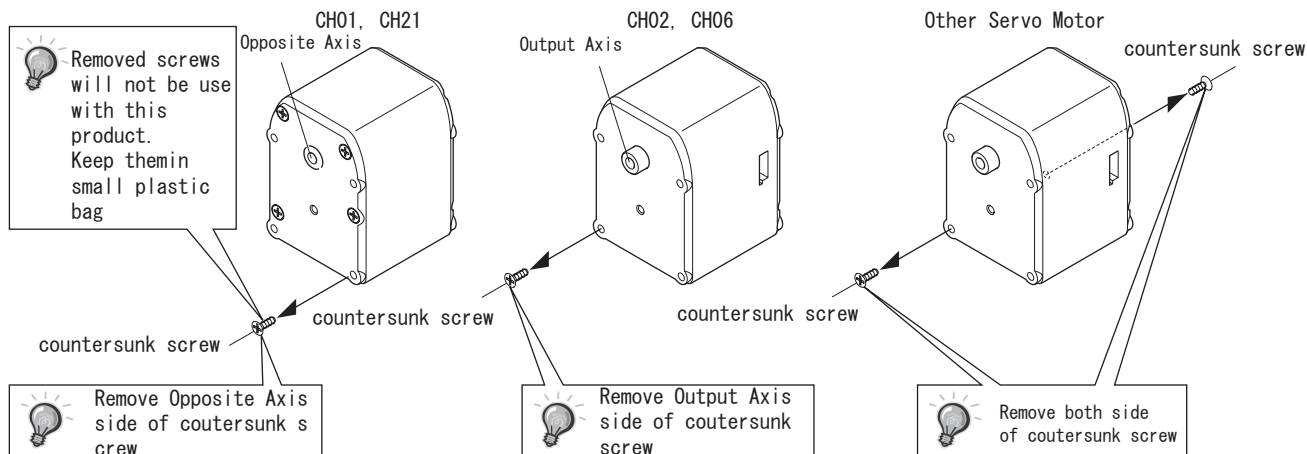

4

Insert connector into Control Board as see applied CH label on Servo Lead

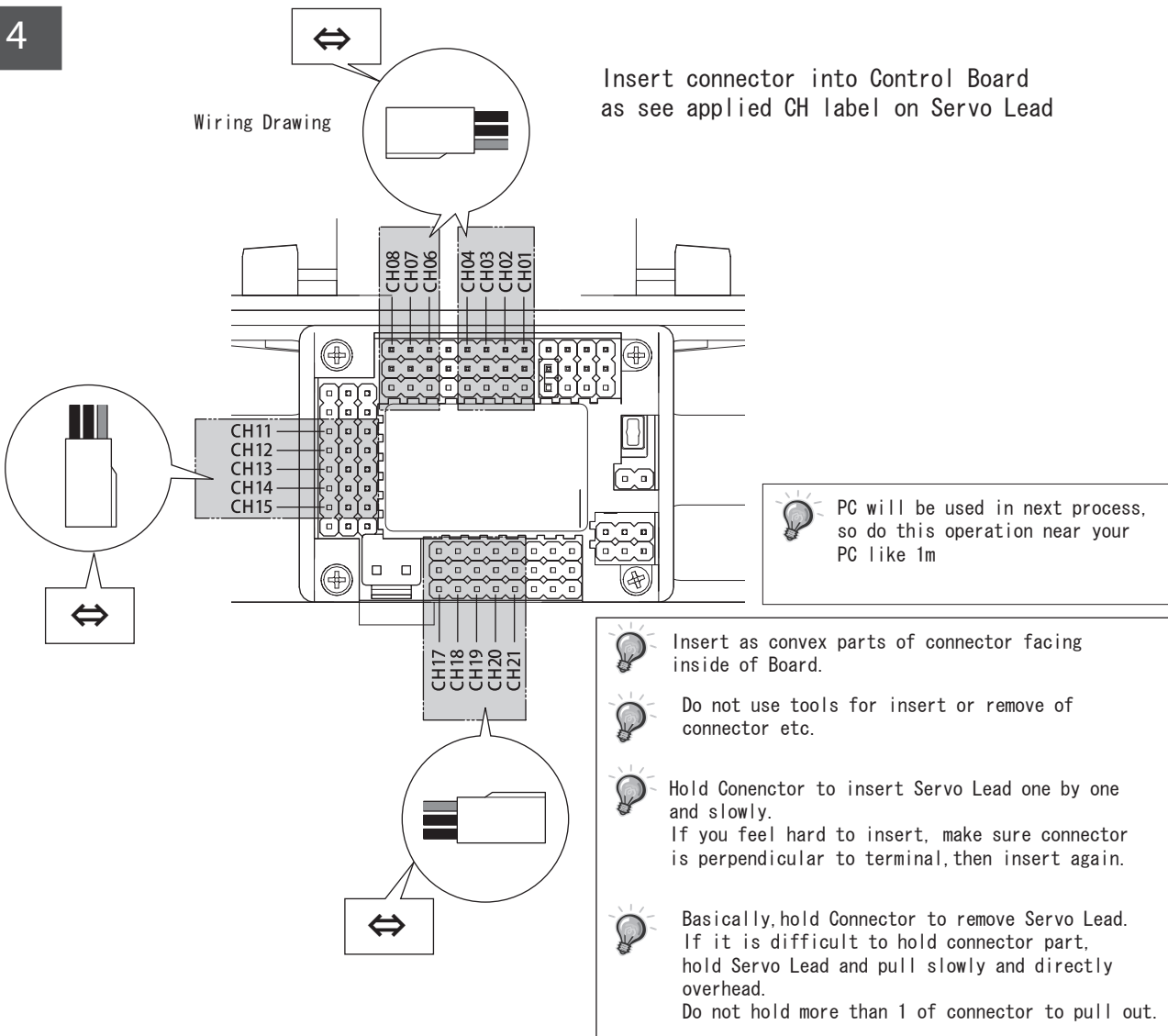

アイコン解説



注意



ポイント



締め込み注意



方向注意

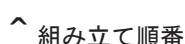

組み立て順番



挟み込み注意



## 2-4 Setting Nutral Position of Servo Motor

Parts/Units from previous operation/step

Li-Po Battery x 3(1-1)  
 Serial USB Adaptor x 1(1-3)  
 Temporarily assembled Body Flame Unit(2-2)  
 CH 1 ~ CH17 Servo Motor (2-3)

New Prats for this step

[65] Battry Hatch x 1  
 [112] Serial Extension Cable x 1  
 [120] Insulating Tape

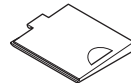

Battry Hatch

 Process of Setting Nutral Potion of Servo Motor is work of setting Nutral Position = setting basing point of action from condition of shipment. This process means basing point of aseemblng and this will affect performace of MANOI, so this should be done completely without skipping. After this process is done, Nutral position ,may be moved by some reason, in that casedo this process again to set nutral position.

1

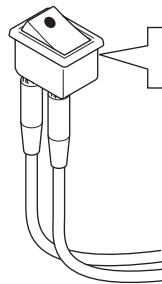

Make sure Power Switch is OFF

2

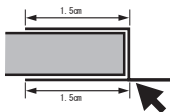
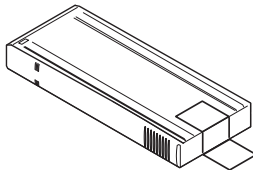

Place Tab and line of underside as straight line

Apply Insulating Tape which is cut about 6cm to one of Li-Po Battery Pack as photo and view.



Apply as tab is an extension of Underside of Battery(side of no MANOI Logo)



If Insulating Tape is cut longer, it will be hard to peel off.



If use longer cut tape, make sure it will not touch terminal and guide.



When the tape starts losing adhesionr, change to new one. Household Vynel tape is acceptable for this.



Apply the tape to one battery pack only. If apply to all of 3 battery packs, it may cause situation of Battry Hatch can not get close-fitting or hard to remove batteries from body because of too tight.

### アイコン解説



注意



ポイント



締め込み注意

<{@顎方向注意

^ 組み立て順番



挟み込み注意

3

\*Follow numbers for assembling order

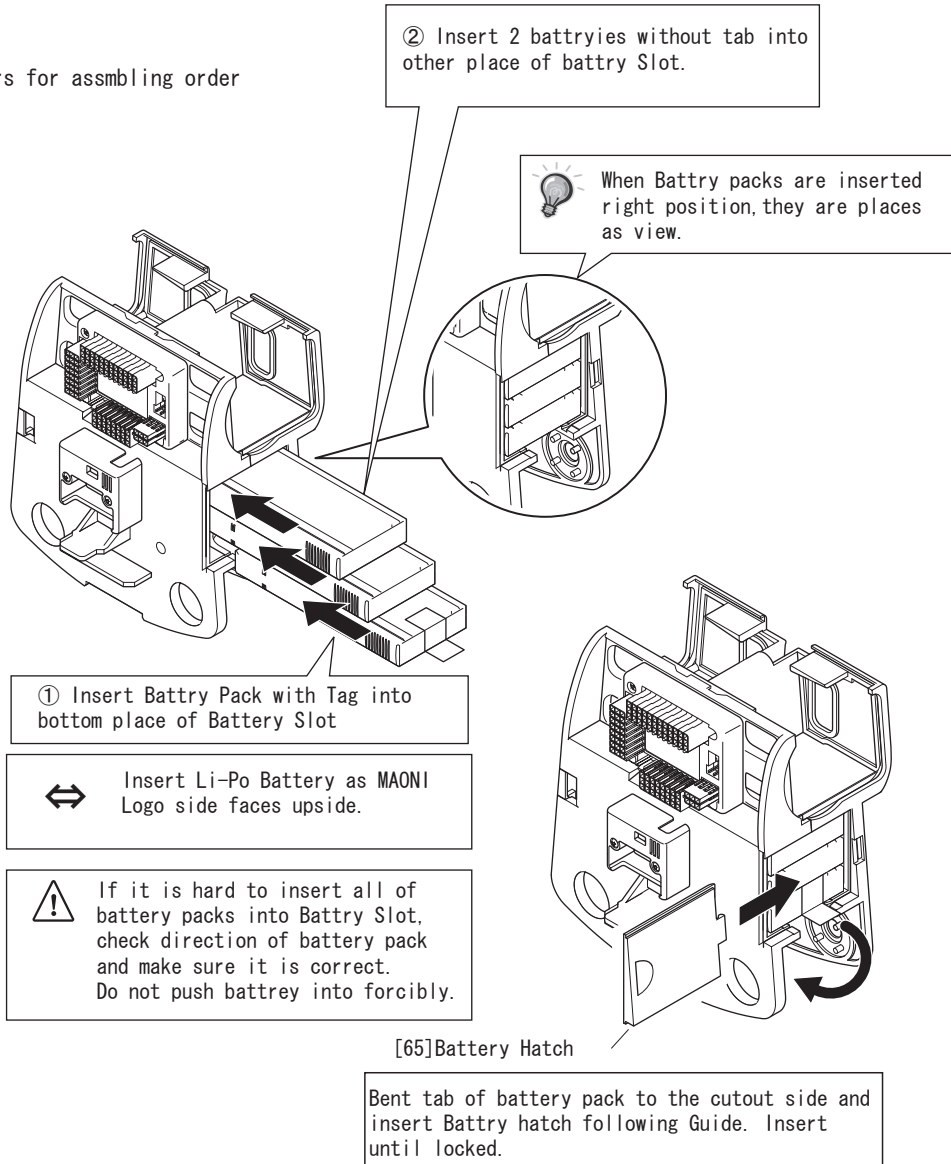

4

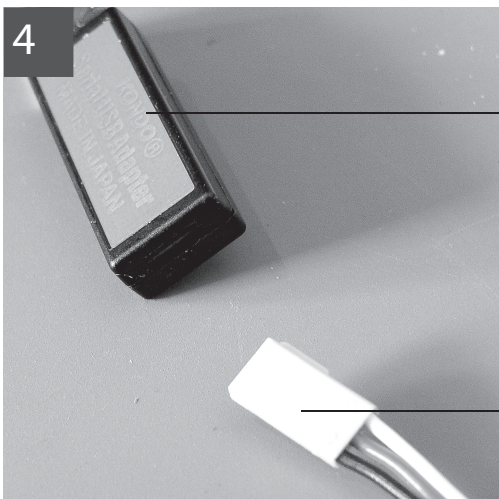

\*作業番号順に組み立てます。

① Serial USB Adaptor

Insert Serial Extension Cable into Serial USB Adaptor

⇔ Match cutout parts of Serial USB Adaptor and convex parts of Serial Extension cable.

Serial Extension cable

アイコン解説



注意



ポイント



締め込み注意



方向注意

組み立て順番



挟み込み注意

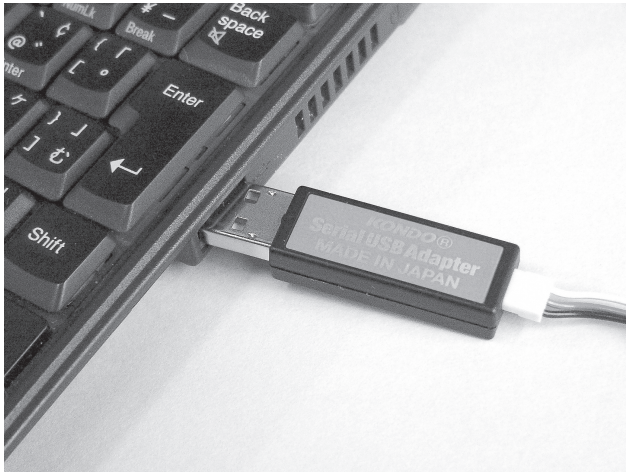

② Connect Serial USB Adaptor into USB Port which was set in Operattion 1-3

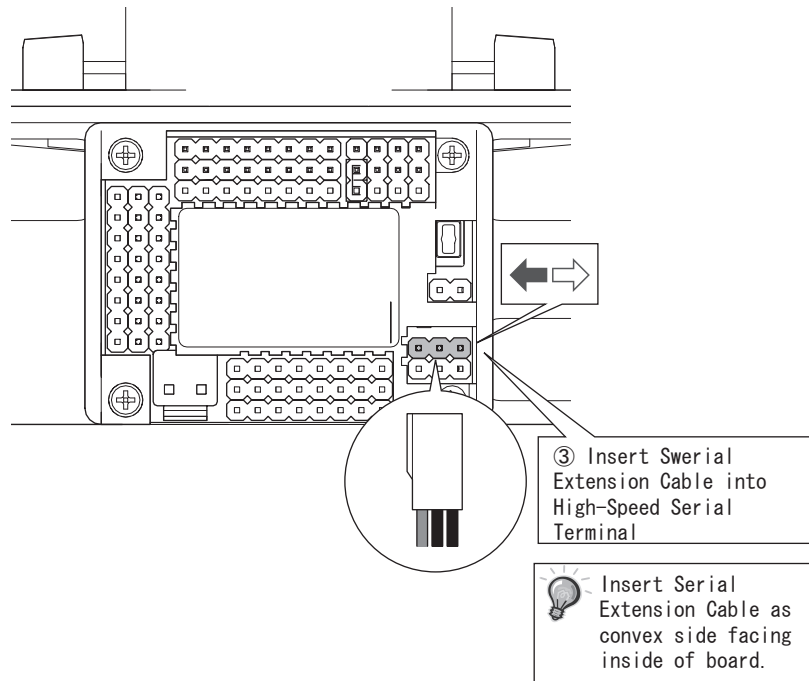

5



Turn PCon and double-click on "HTH3\_070205.exe" which was installed at Opeartion 1-2.

アイコン解説



注意



ポイント



締め込み注意

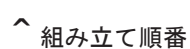

挟み込み注意

6

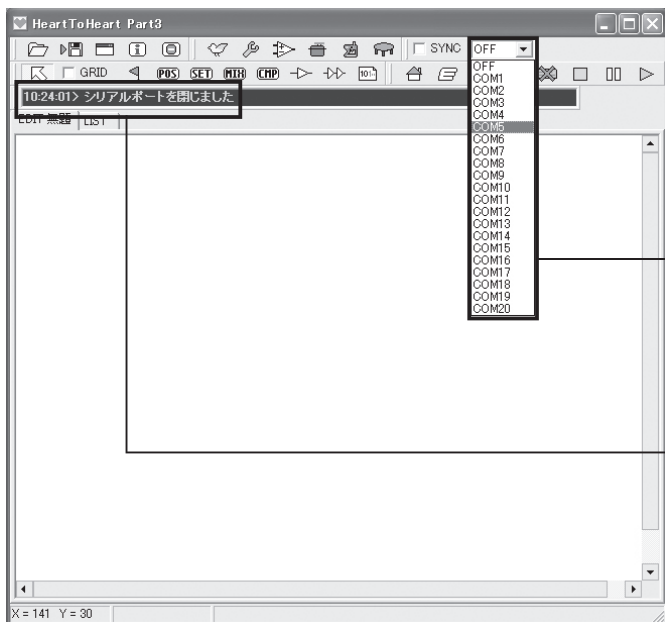

Choose pertinent COM port form "COM" at right above of HTH3 as referring COM "X" s¥which was checked in Operation 1-4.



After select COM port, message of 「COM"X"設定完了」[COM"X" is set] is displayed, and it is ok.

7

① Trun Power Switch on.



② Check on [SYNC].

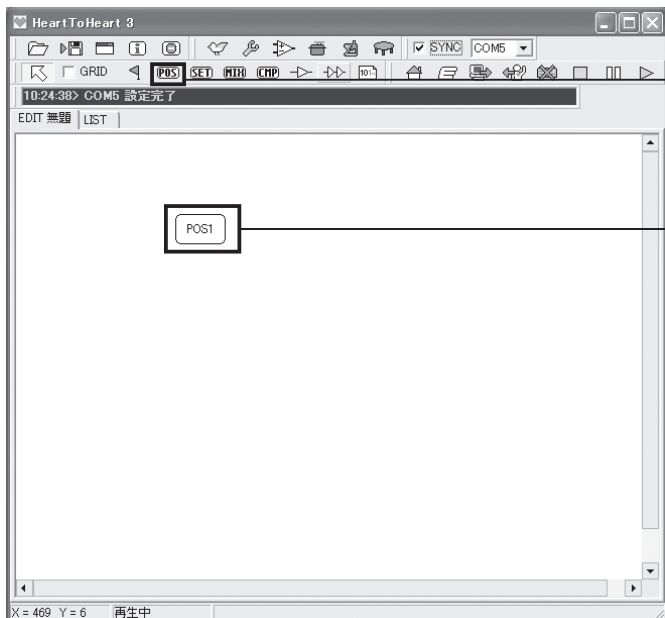

③ Choose [SYNC] of HTH3. Click on data sheet to place [POS1].

アイコン解説



注意



ポイント



締め込み注意



<{@寄方向注意

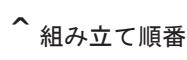

^組み立て順番



挟み込み注意

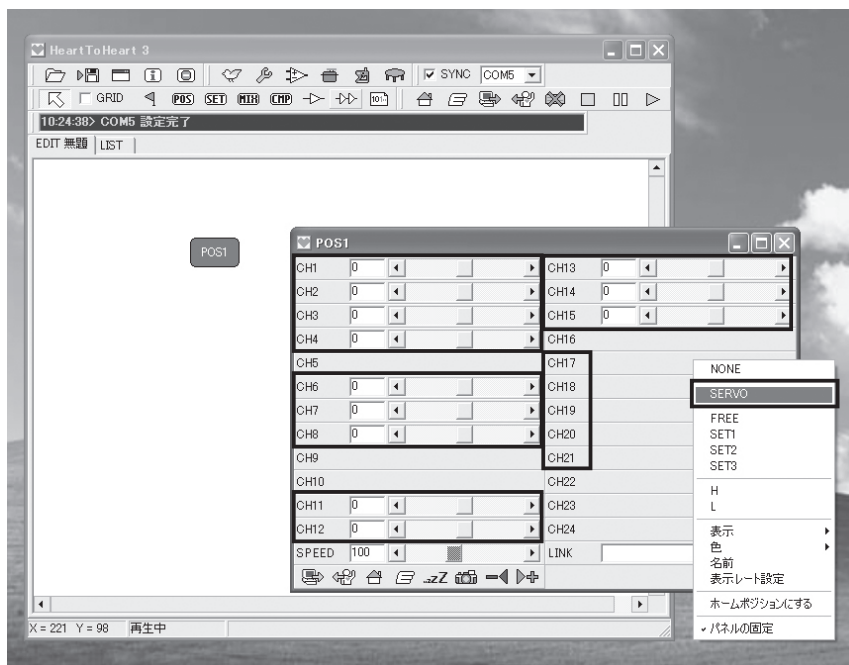

① Double-Click [POS1] to open.

② Right Click on CH1~CH4, CH6~CH8, CH11~CH15, CH7~CH21, respectively, and choose [Servo] from dialogue.



Servo motor which is chosen on [Servo] will return to Nutral Postion (Basic Position) immidately.



Some servo motors move over a little from Nutral position and others move over a lot from Nutral position, when they are shipped from the factory.

③ After check connected Ch No., move slide bar of pertinent CH to check if Output Axis of Servo Motor moves or not.



If Servo motor does not move, turn switch off and check Servo Motor, Servo lead, and terminal of Control Board well, then connected again.

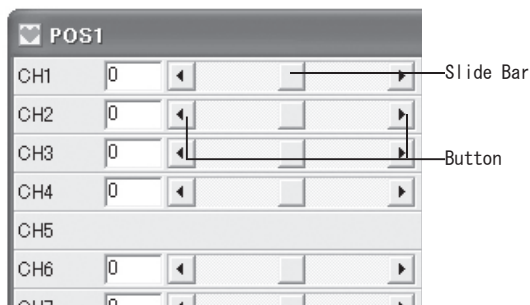

④ Use Slide Bar and Button to return numerical number to [0].



[0] is basic point.

Set nutral position of all CH, then turn power switch off.

#### アイコン解説



注意



ポイント



締め込み注意



< { @ 頭

方向注意



組み立て順番



挟み込み注意

## 2-5 Disassemble of temporarily Assembled Unit

In this process, disassemble some of temporarily assembled parts in Operation 2-2 for further steps.

以前の工程から引き継ぐ部品 / ユニット

temporarily assembled Body Flame (2-4)

新しく使用する部品

None

1

\*Follow numbers for disassembled order.

### ① Remove Battery Hatch



Put finger at reentrant part and pull out

### ② Remove Li-Po Battery



Remove all of 3 battery packs. First, pull tab of battery at the lowest part. Put finger into space of the lowest part which is empty now to slide batter pack out like push a little up the battery pack.

2

Remove all connectors which are connected with Control Board.

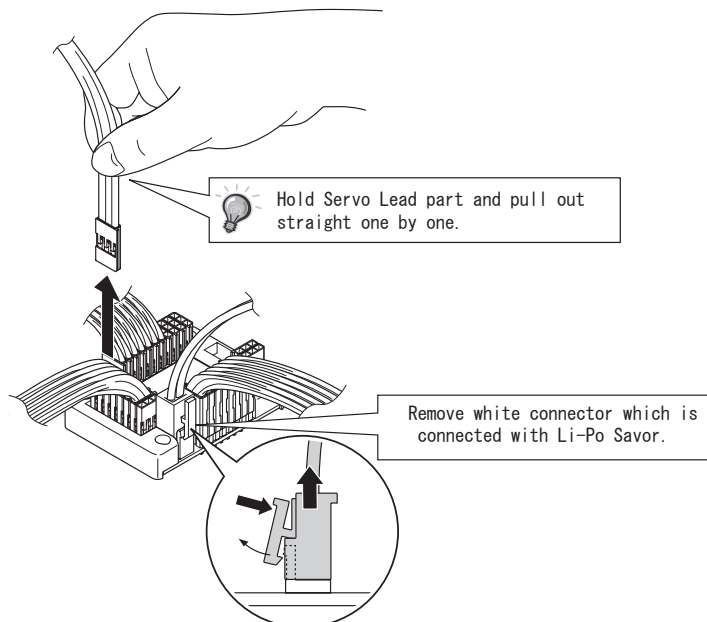

#### アイコン解説



注意



ポイント



締め込み注意



<

@

方向注意



組み立て順番



挟み込み注意

3

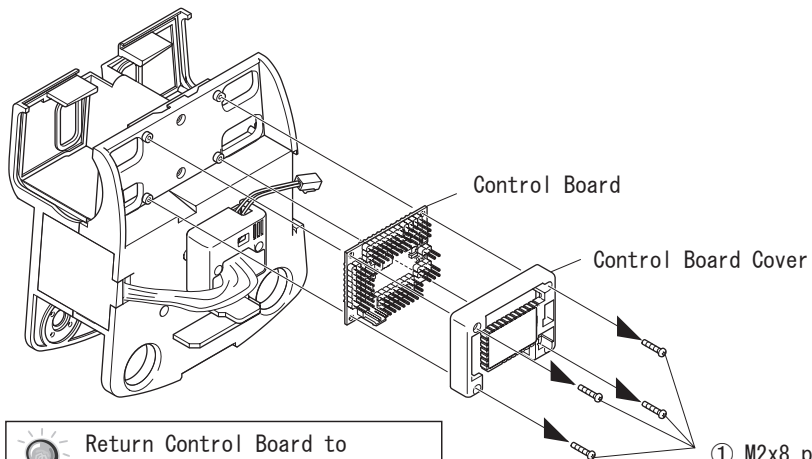

💡 Return Control Board to prevention bag of static electricity and keep it until next time it will be used.

💡 Return removed screws to original plastic bag or keep it with memo of its length and keep it until next time it will be used. Keep screws and Control Board separately.

- ① M2x8 pan-head Tapping Screw
- ② Remove insulating tape

4

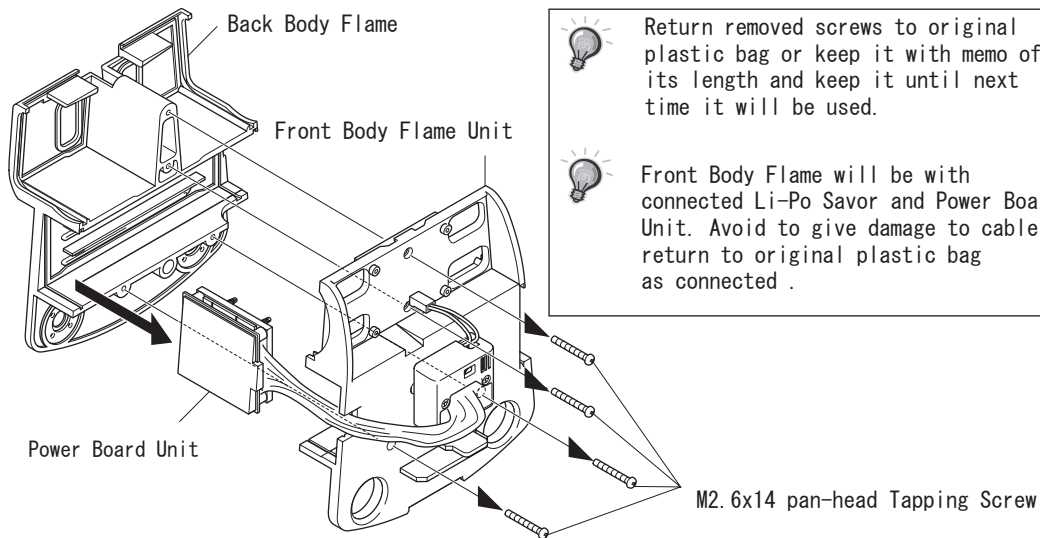

💡 Return removed screws to original plastic bag or keep it with memo of its length and keep it until next time it will be used.

💡 Front Body Flame will be with connected Li-Po Savor and Power Board Unit. Avoid to give damage to cable, return to original plastic bag as connected .

アイコン解説



注意



ポイント



締め込み注意

< { @ ■ 方向注意

^ 組み立て順番



挟み込み注意



# 工程 03 Assembling Right Arm (Pack 3)

## 3-1 Assembling Right Joint Unit

Parts/Units from previous operation/step

None

New Parts for this step

- [2] Arm Joint x 2
- M2 x 6 pan-head Machine Screw x 4
- M2 Nut x 4

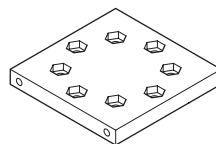

Arm Joint

1

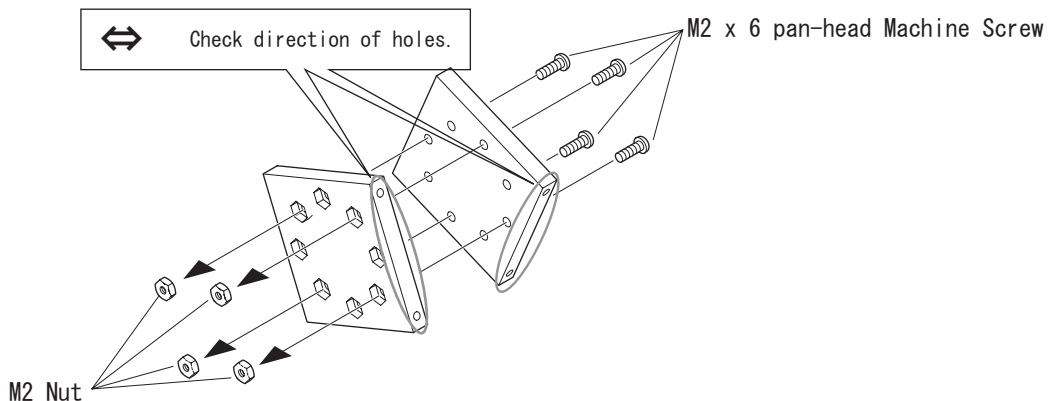

2

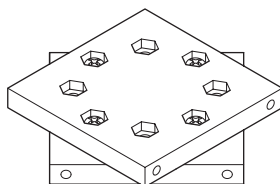

Final Drawing

### アイコン解説



注意



ポイント



締め込み注意

< @ 方向注意

^ 組み立て順番



挟み込み注意

## 3-2 Assembling Right Elbow

Parts/Units from previous operation/step

「CH8」 Servo Motor (→2-4)  
Right Joint Unit(3-1)

New Parts for this step

[3] Front Arm Plate x 1

[4] Rear Arm Plate x 1

M2 x 16 countersunk Machine Screw x 4  
M2 x 10 countersunk Tapping Screw x 8

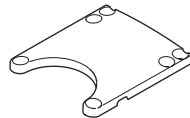

Front Arm Plate

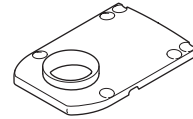

Rear Arm Plate

1



M2 x 10 countersunk Tapping Screw

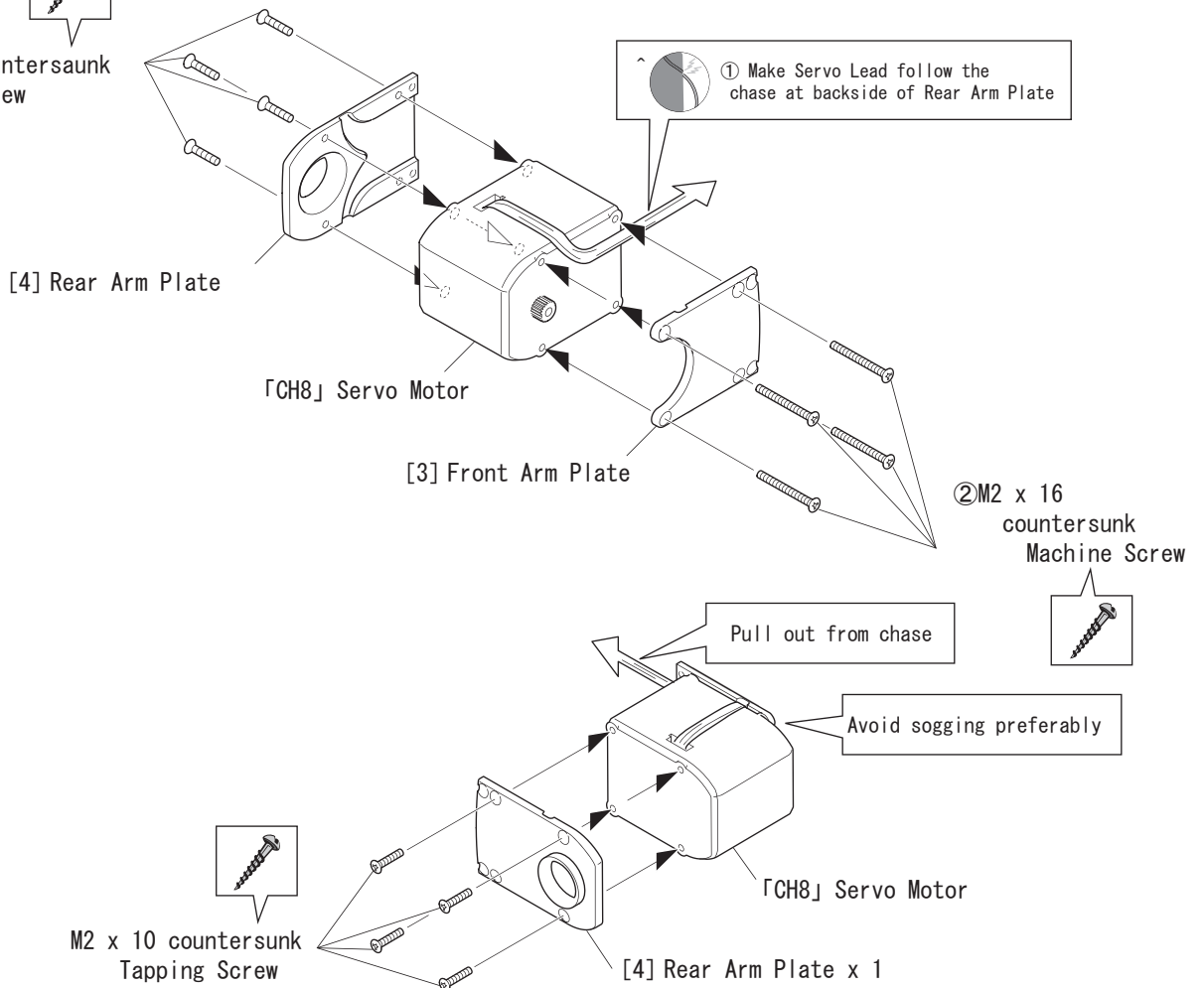

アイコン解説



注意



ポイント



締め込み注意

< [ @ 顎 ] 方向注意

^ 組み立て順番



挟み込み注意

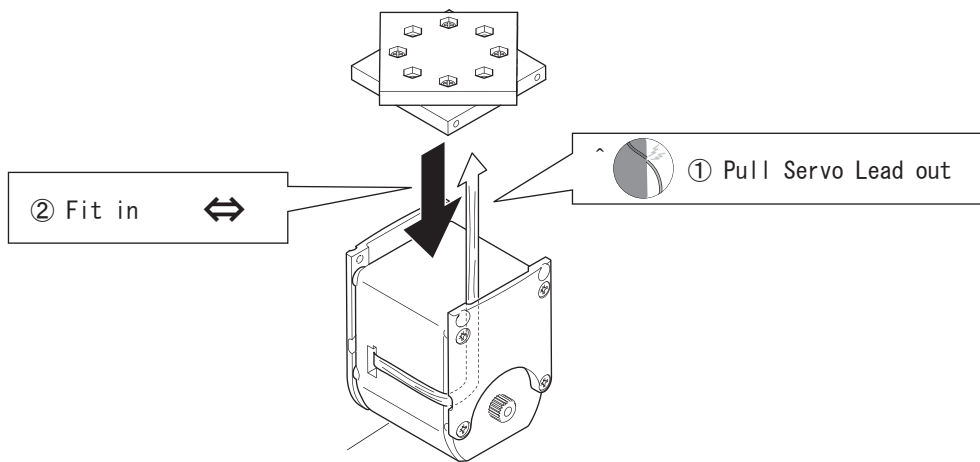

The one assembled in 1

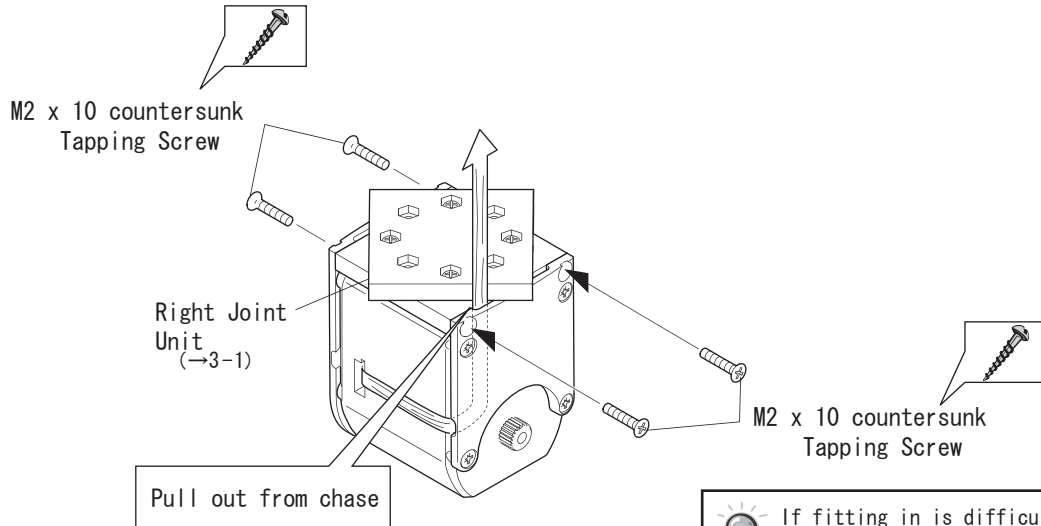

Backside

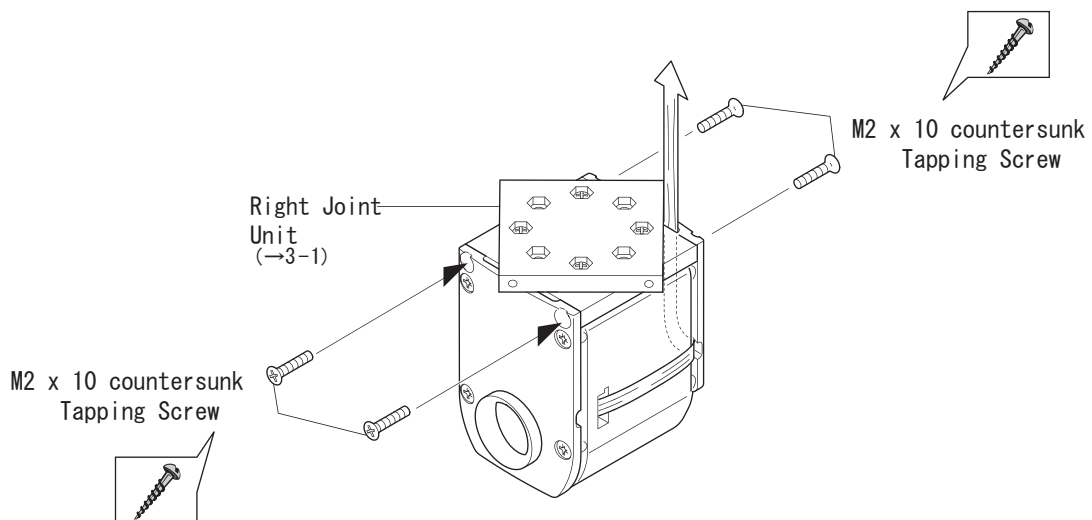

アイコン解説



注意



ポイント



締め込み注意

< @ 方向注意

^ 組み立て順番



挟み込み注意

### 3-3 Assembling of Right Upper Arm

Parts/Units from previous operation/step

「CH7」 Servo Motor (→ 2-4)

「Right Elbow」Unit (→ 3-2)

New Parts for this step

[5] Front Arm Flame x 1

[6] Rear Arm Flame x 1

[7] Arm Side Cover x 1

M2 x 16 countersunk Machine Screw x 4

M2 x 10 countersunk Tapping Screw x 8

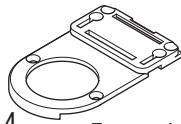

Front Arm Flame

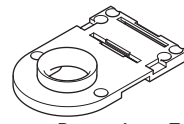

Rear Arm Flame

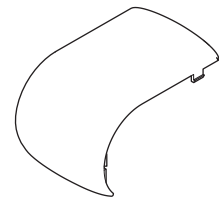

Arm Side Cover

1

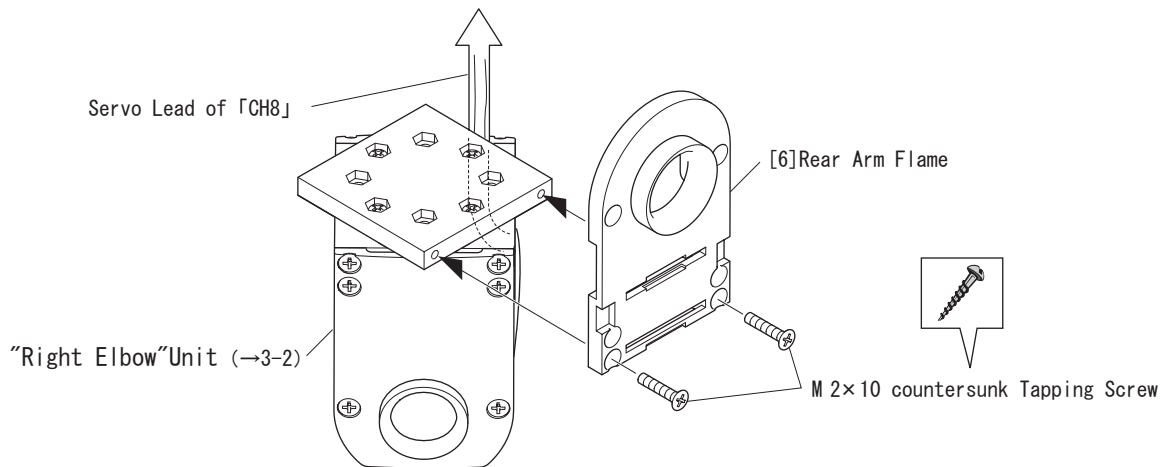

2

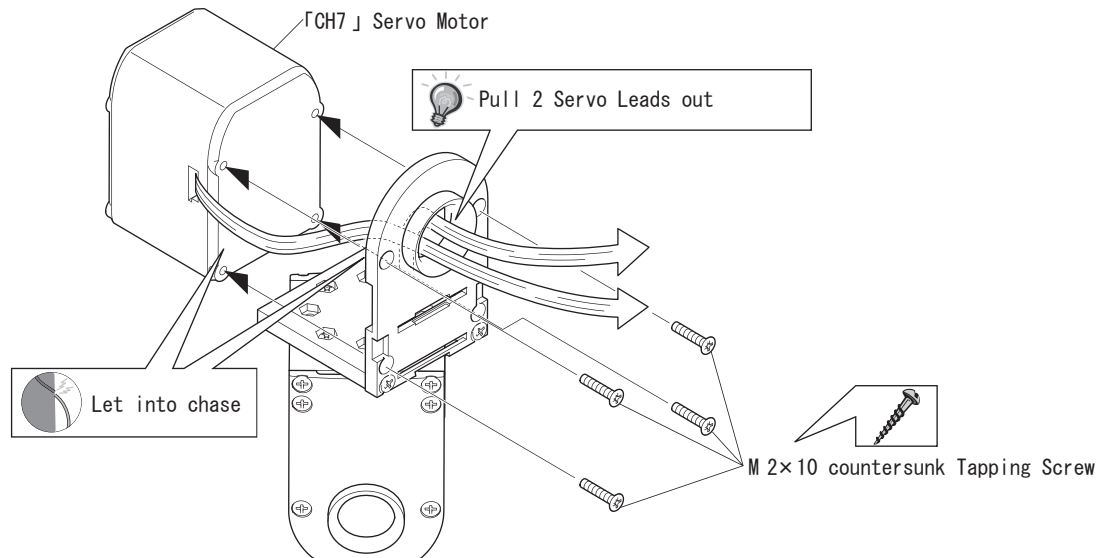

アイコン解説



注意



ポイント



締め込み注意



◀ 顎方向注意

^ 組み立て順番



挟み込み注意

3

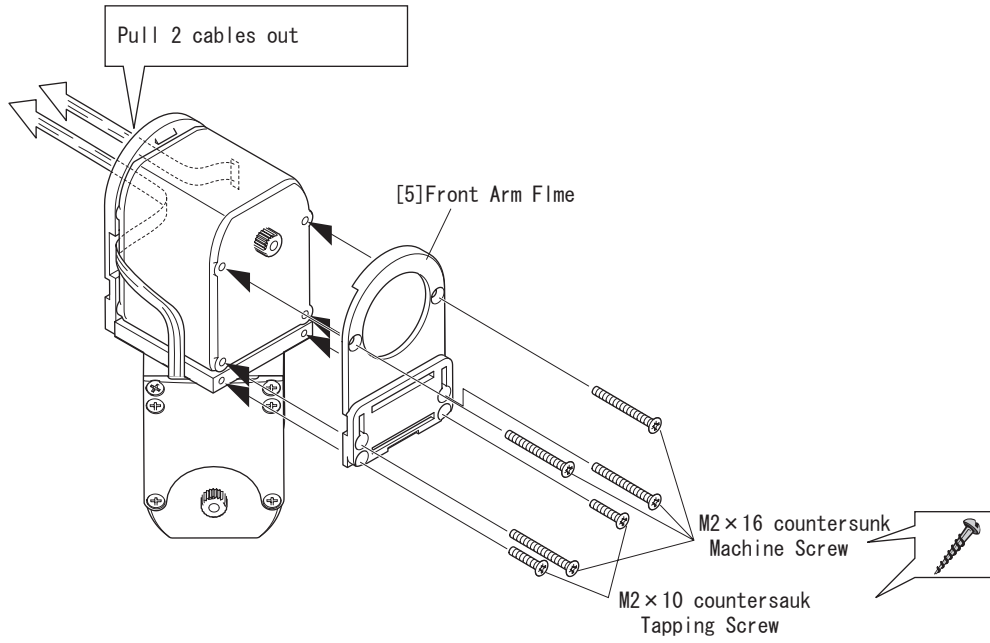

4

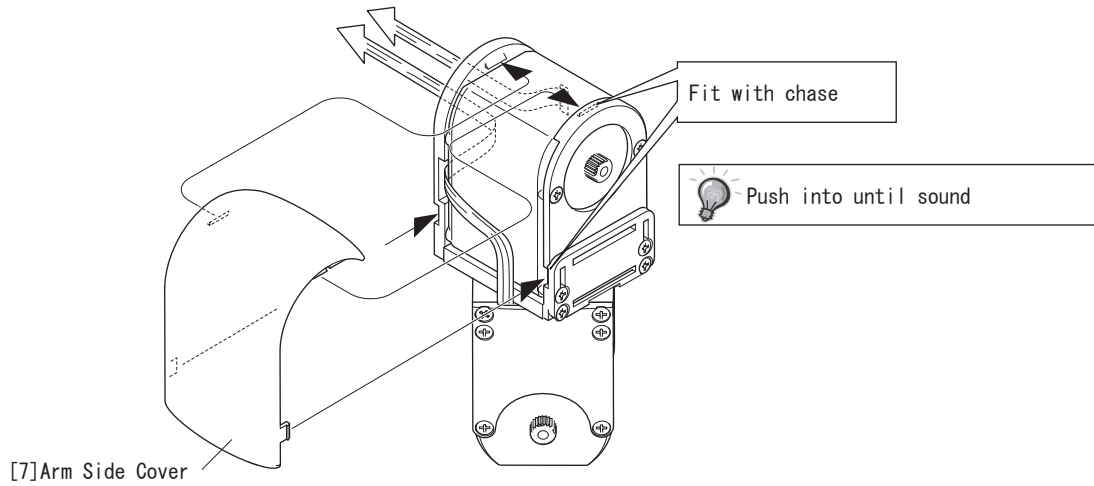

アイコン解説



注意



ポイント



締め込み注意



方向注意

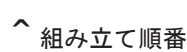

組み立て順番



挟み込み注意

## 3-4 Assembling Right Hand

Parts/Units from previous operation/step

"Right Elbow+Right Upper Arm" Unit (→3-3)

New Parts for this step

[73] Low Height Servo Horn x 1

[8] Front Hand Right x 1

[9] Rear Hand Right x 1

M2 x 5 countersunk Tapping Screw x 4

M2.6 x 10 pan-head Tapping Screw x 3

M3 x 8 Blind Tapping Screw x 1



Low Height Servo Horn

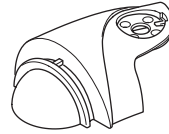

Front Hand Right

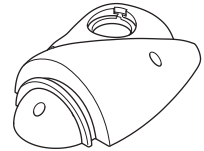

Rear Hand Right

Selicon Grease

1

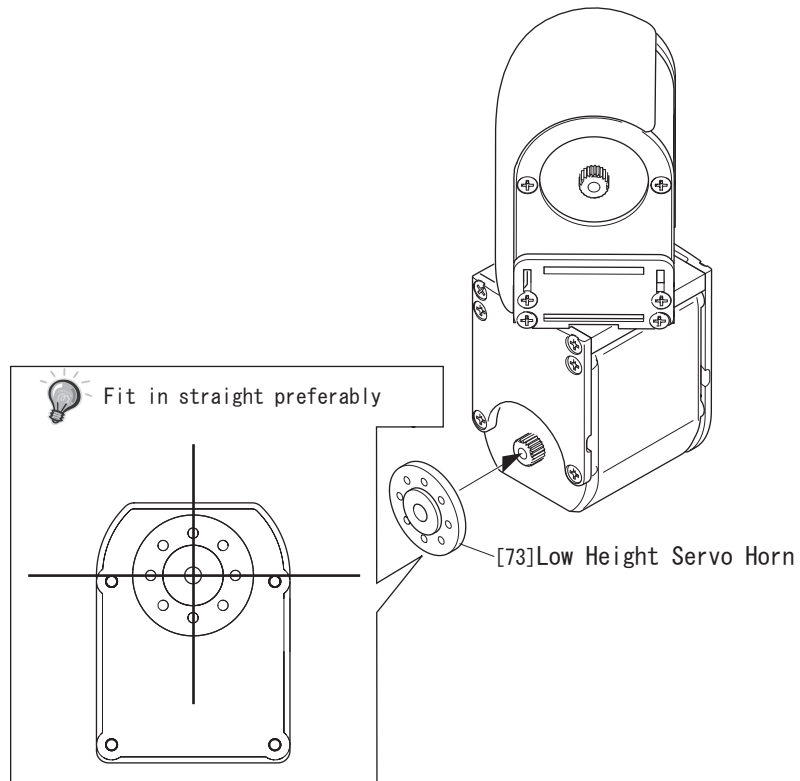

アイコン解説



注意



ポイント



締め込み注意

<[@顎方向注意

^ 組み立て順番



挟み込み注意

2

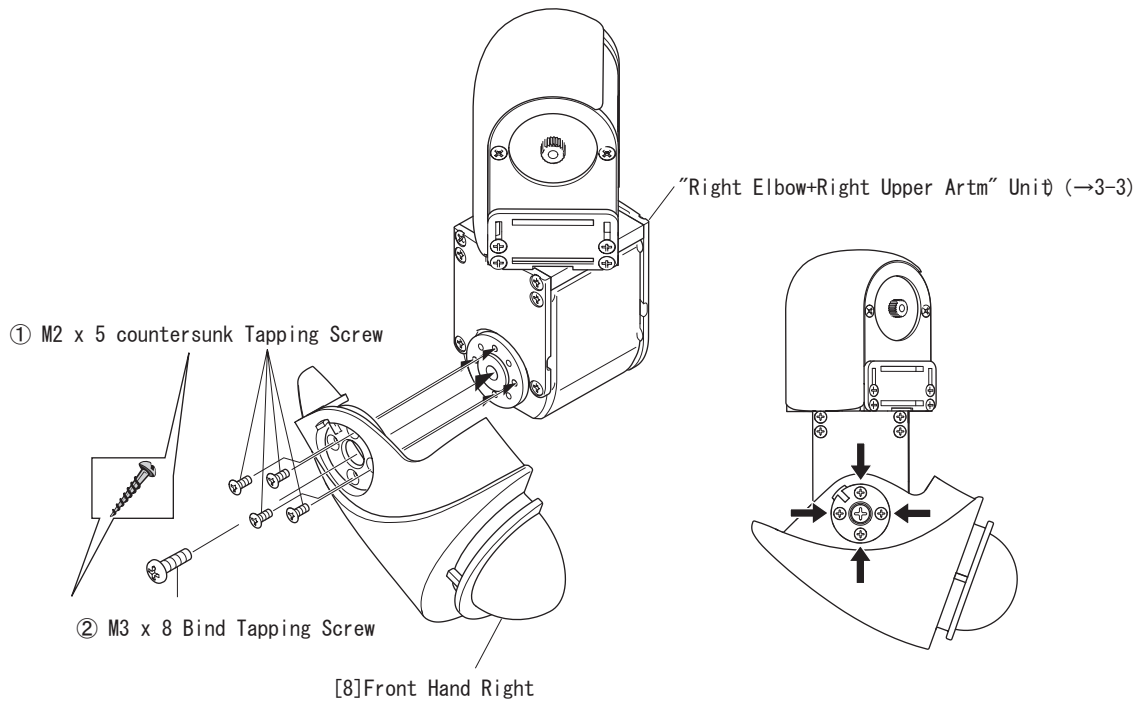

3

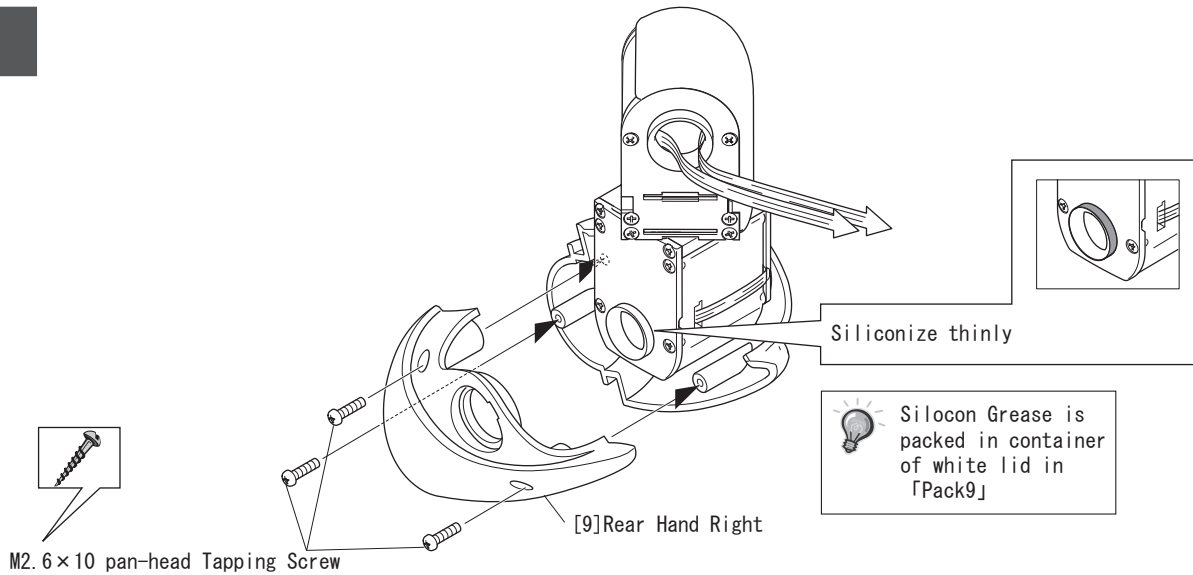

### Silicon Grease

Use cotton swab etc to siliconize thinly.

Too much grease will be load at siliconized place and will cause poor performnce.

Be careful with Below mattes.

1. Keep the grease away from children
2. Wash away by soap etc when the grease is on skin
3. See doctor when the grease is in eyes or swallow it.

### アイコン解説



注意



ポイント



締め込み注意

< { @ 方向注意

^ 組み立て順番



挟み込み注意



## 3-5 Assembling Right Shoulder

Parts/Units from previous operation/step

「CH6」 Servo Motor (2-4)

“Right Arm” Unit (→ 3-4)

New Parts for this step

[73] Low Height Servo Horn x 2

[11] Front Arm Guide x 1

[12] Rear Arm Guide x 1

[13] Shoulder Base x 1

[10] Arm Base x 1

M2 x 5 countersunk Tapping Screw x 4

M2 x 20 countersunk Machine Screw x 4

M2.6 x 10 countersunk Tapping Screw x 4

M3 x 8 Bind Tapping Screw x 2



Low Height Servo Horn

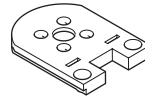

Front Arm Guide

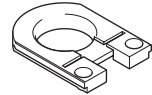

Rear Arm Guide

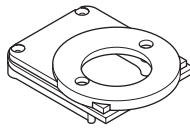

Shoulder Base

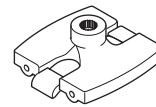

Arm Base

1

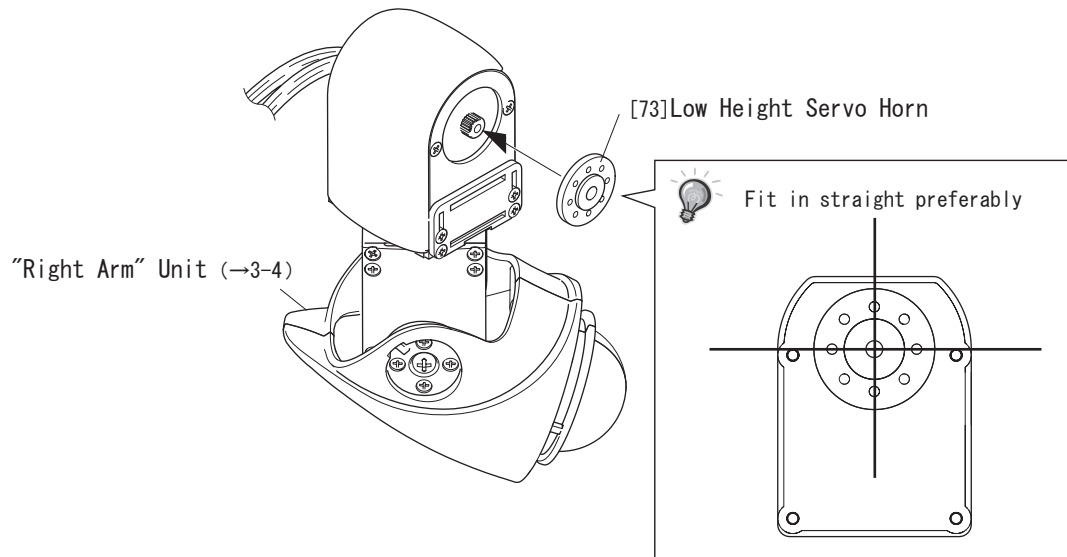

アイコン解説



注意



ポイント



締め込み注意



<[@喜方向注意



組み立て順番



挟み込み注意

2

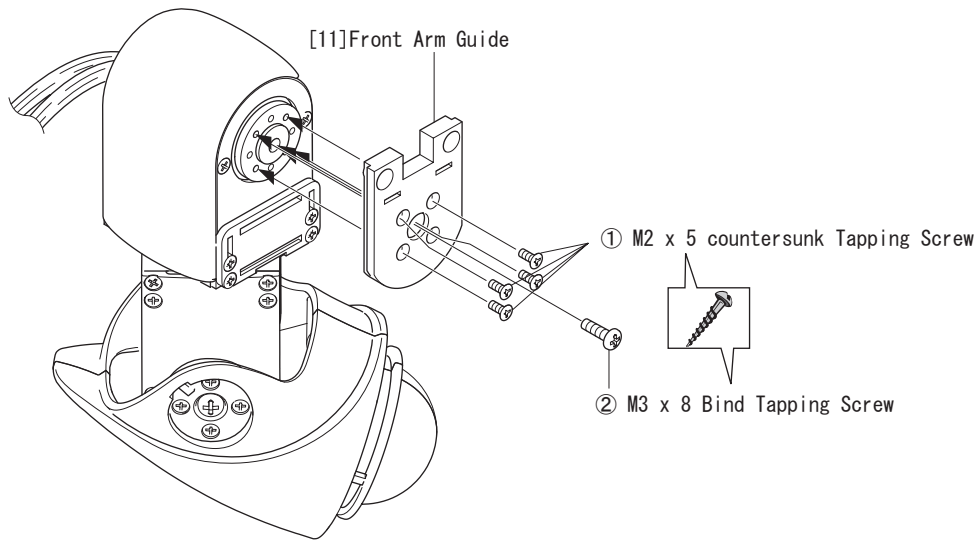

3

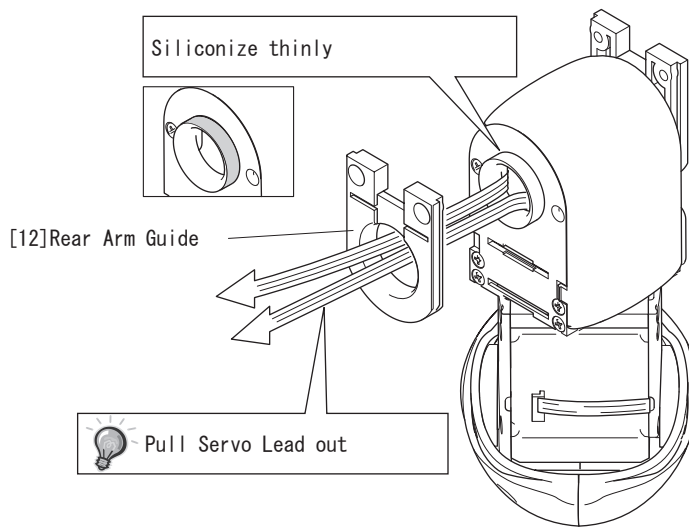

4

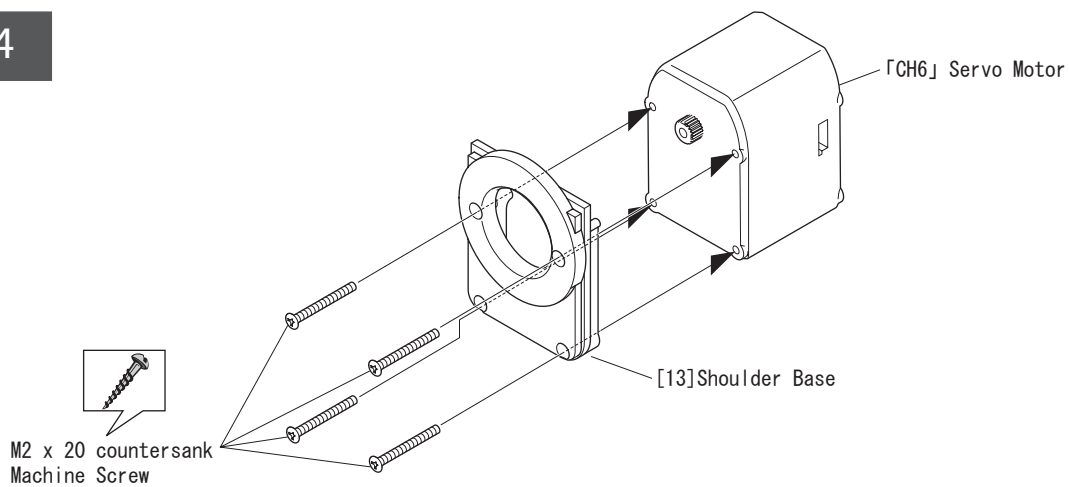

アイコン解説



注意



ポイント



締め込み注意



方向注意

組み立て順番



挟み込み注意

安全のための  
注意事項

付属製品に  
ついて

組み立て

ソフトウェア  
の設定

MANO  
遊び方

での

オプションパー  
ツの取り付け

故障かなと  
思ったら

ユーザー相談  
室のご案内

用語集

パーツ販売  
リスト

展開図

5

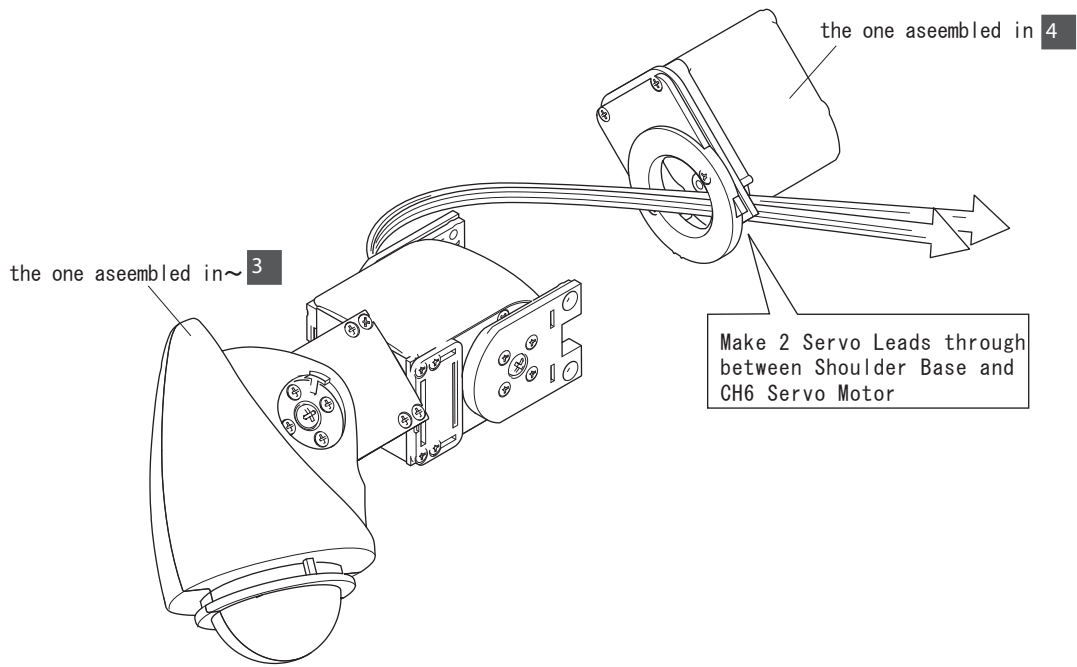

6

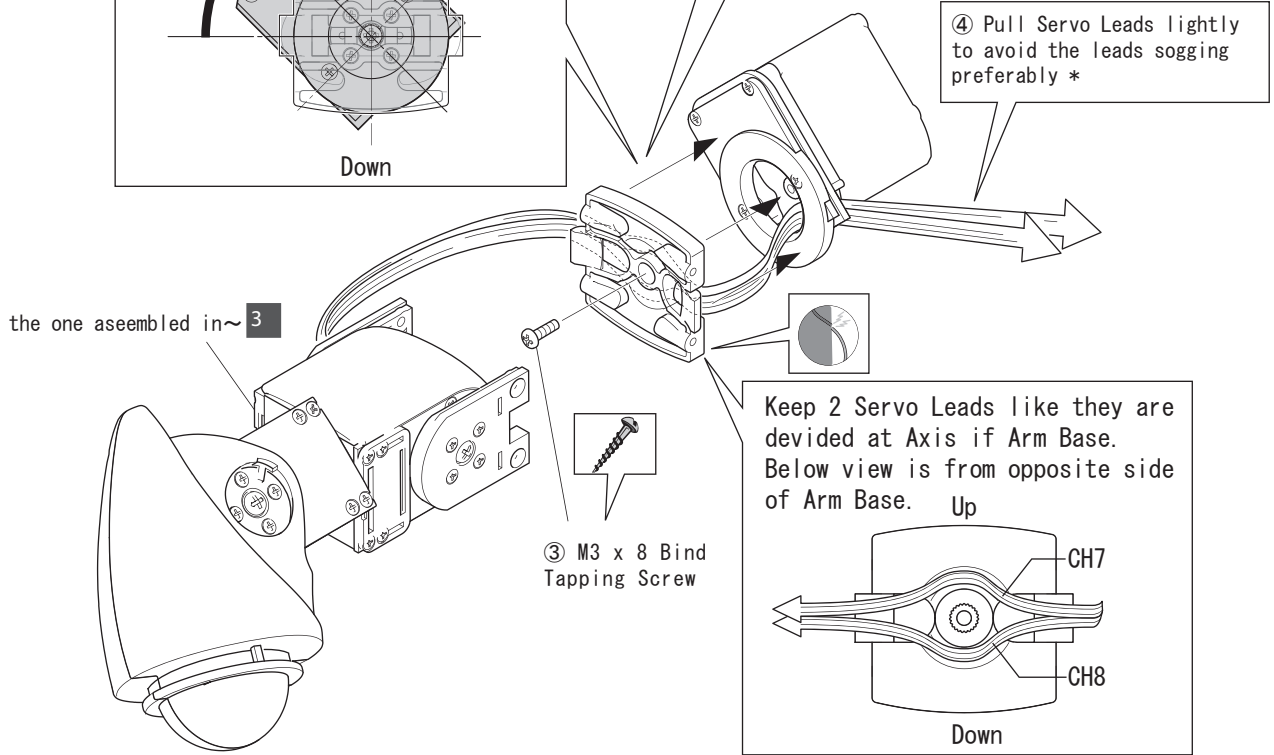
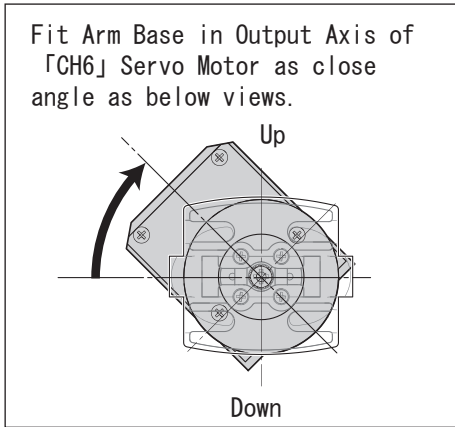

アイコン解説



注意



ポイント



締め込み注意

< { @ 喜 方向注意

^ 組み立て順番



挟み込み注意

7

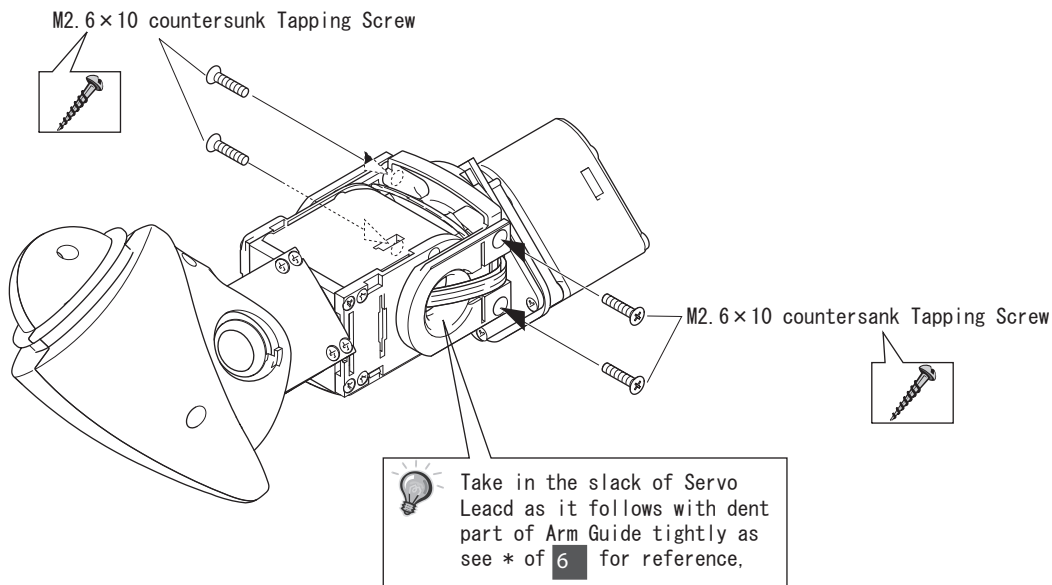

安全のための  
注意事項

付属製品に  
ついて

組み立て

ソフトウェア  
の設定

MANO  
での  
遊び方

オプションパー  
ツの取り付け

故障かなと  
思ったら

ユーザー相談  
室のご案内

用語集

パーツ販売  
リスト

展開図

アイコン解説



注意



ポイント



締め込み注意



方向注意

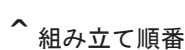

組み立て順番



挟み込み注意

## 3-6 Attaching Covers (Right Arm)

Parts/Units from previous operation/step

"Right Arm+Right Shoukder" Unit (→ 3-5)

New Prats for this step

- [14] Arm Cover x 2
- [15] Arm Screw Cover x 2
- [16] Hand Cap x 2
- [17] Knuckle Right

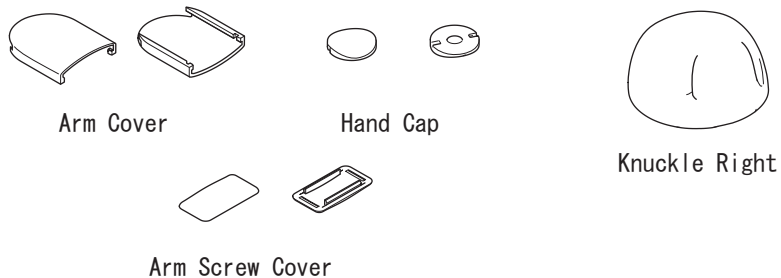

1

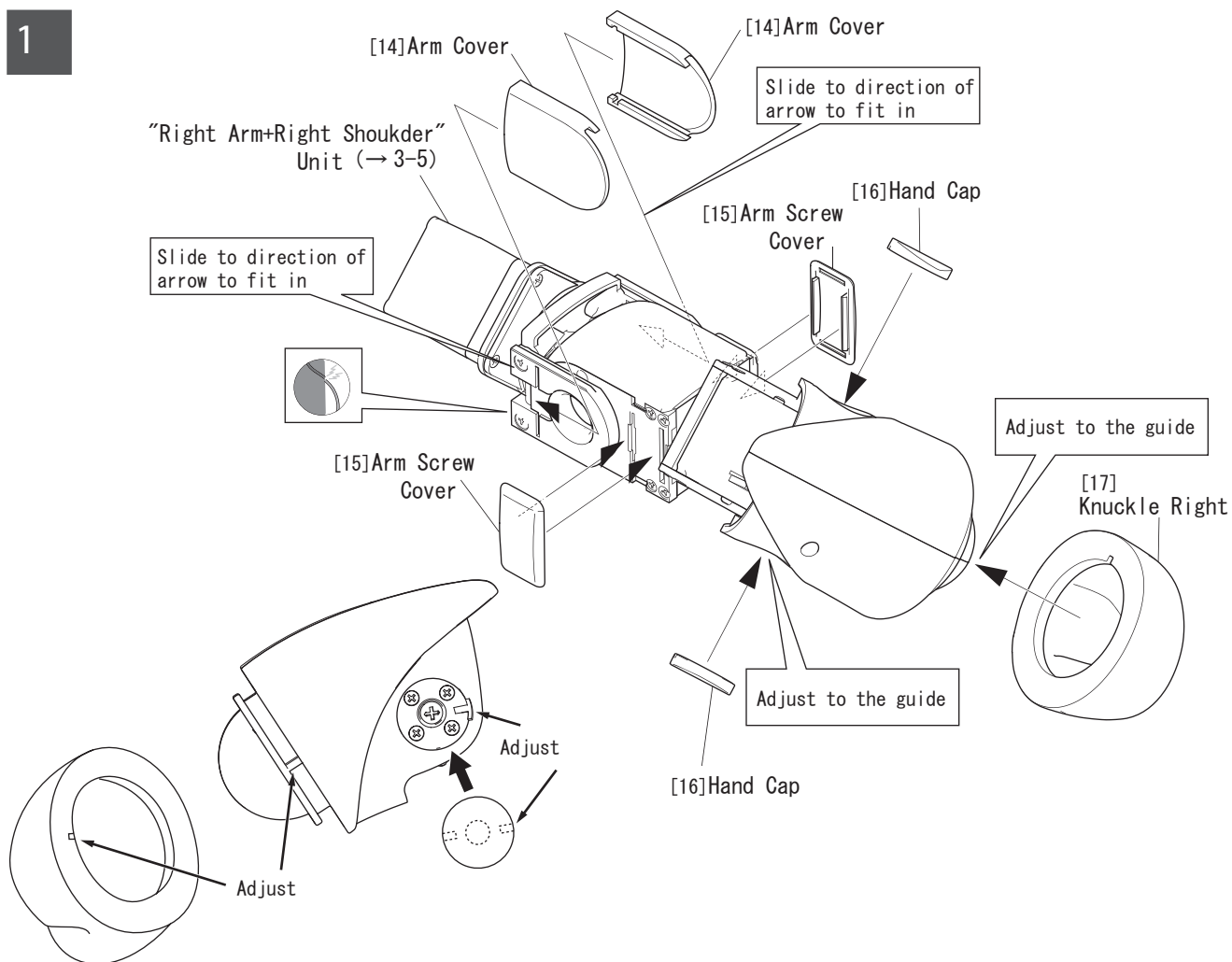

アイコン解説



注意



ポイント



締め込み注意

< @ 喜 方向注意



組み立て順番



挟み込み注意

### 3-70operation 3 Final Drawing

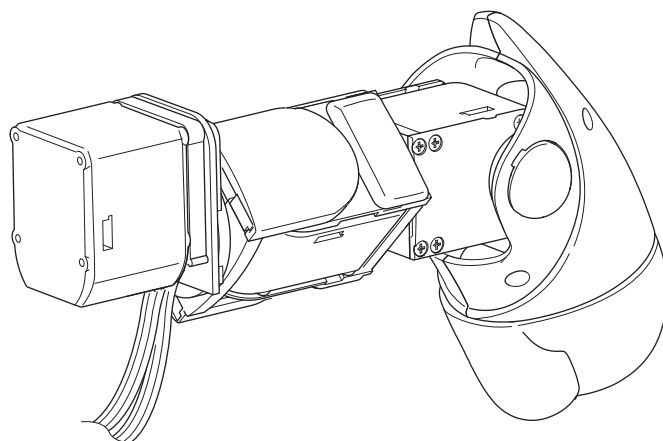
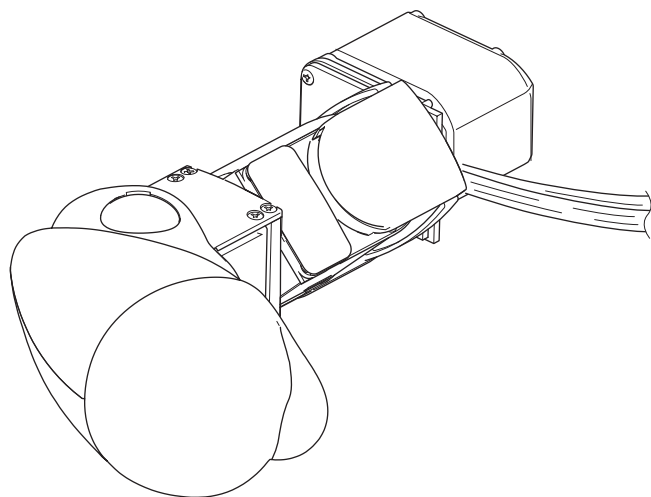

安全のための  
注意事項

付属製品に  
ついて

組み立て

ソフトウェア  
の設定

MANUAL  
での  
遊び方

オプションパー  
ツの取り付け

故障かなと  
思ったら

ユーザー相談  
室のご案内

用語集

パーツ販売  
リスト

展開図

#### アイコン解説



注意



ポイント



締め込み注意



方向注意



組み立て順番



挟み込み注意

# 工程 04 Assembling Left Arm (Pack 4)

## 4-1 Assembling Left Joint Unit

Parts/Units from previous operation/step

None

New Parts for this step

[2] Arm Joint x 2  
M2 x 6 pan-head Machine Screw x 4  
M2 Nut x 4

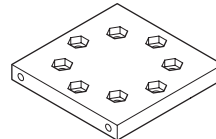

Arm Joint

1

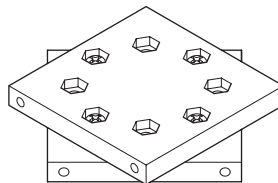
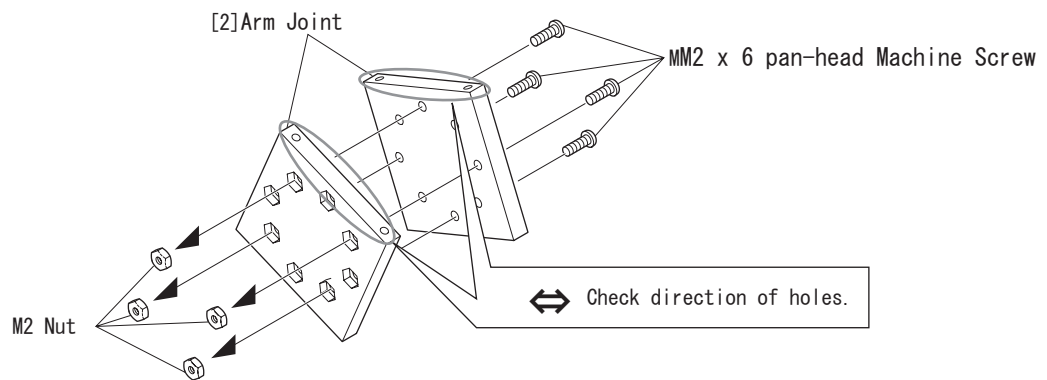

アイコン解説



注意



ポイント



締め込み注意

< @ 顎 方向注意



組み立て順番



挟み込み注意



## 4-2 Assembling Left Elbow

Parts/Units from previous operation/step

「CH14」 Servo Motor (→2-4)  
Left Joint Unit(3-1)

New Parts for this step

[3] Front Arm Plate x 1

[4] Rear Arm Plate x 1

M2 x 16 countersunk Machine Screw x 4

M2 x 10 countersunk Tapping Screw x 8①

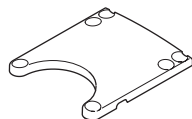

Front Arm Plate

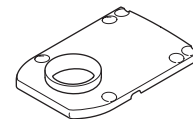

Rear Arm Plate

1

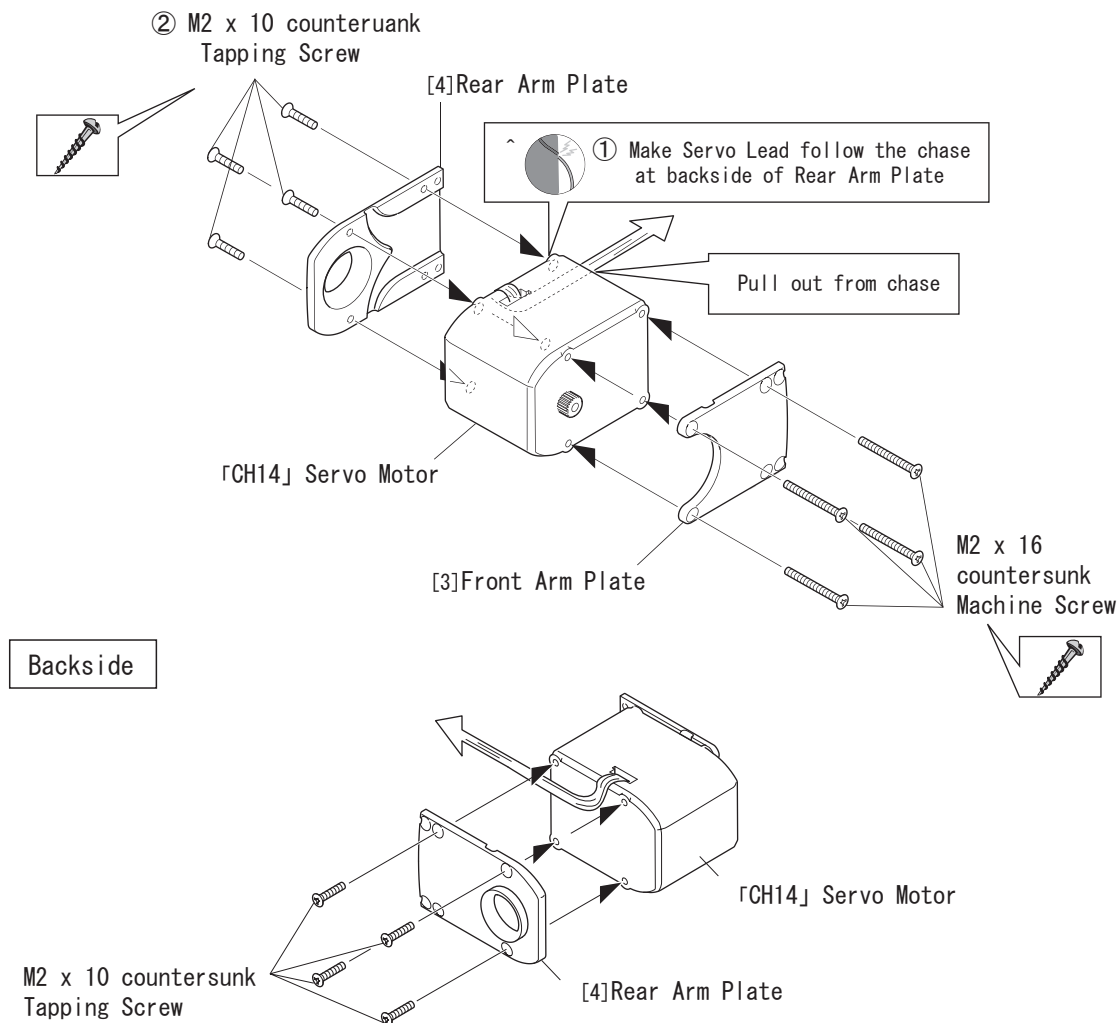

アイコン解説



注意



ポイント



締め込み注意

< { @ 喜 方向注意

^ 組み立て順番



挟み込み注意

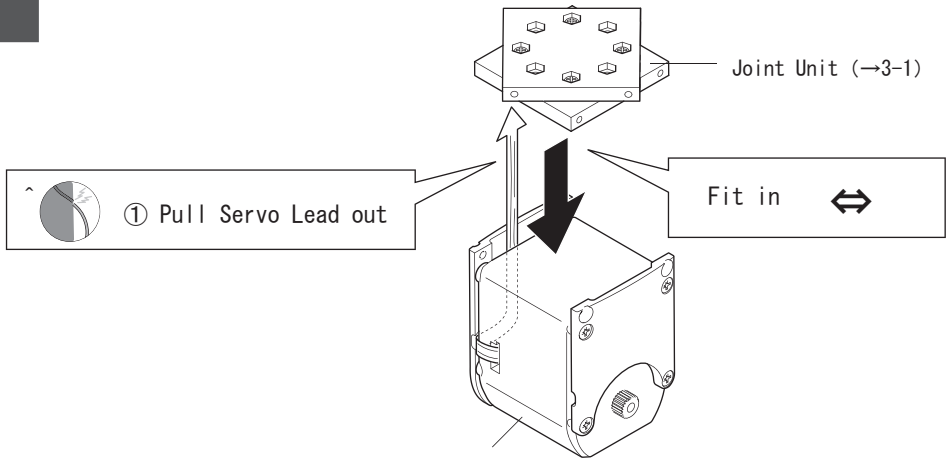

The one assembled in 1

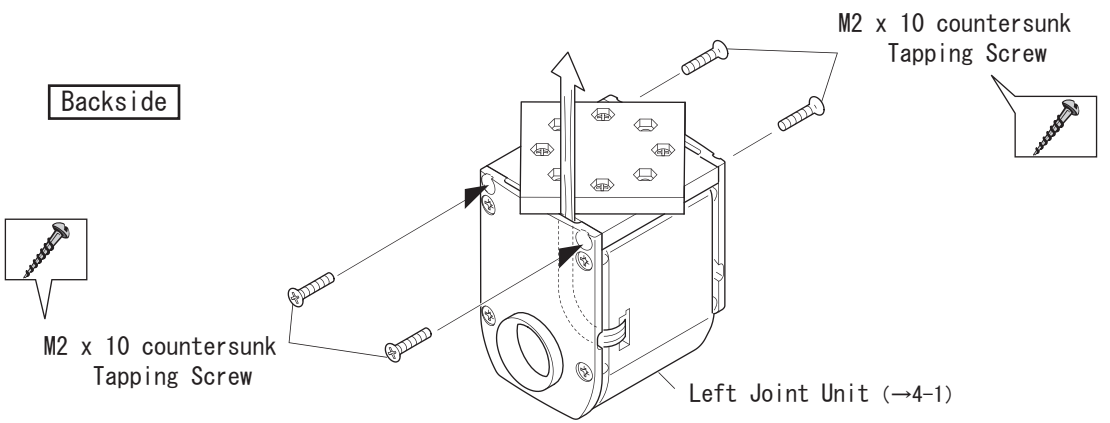
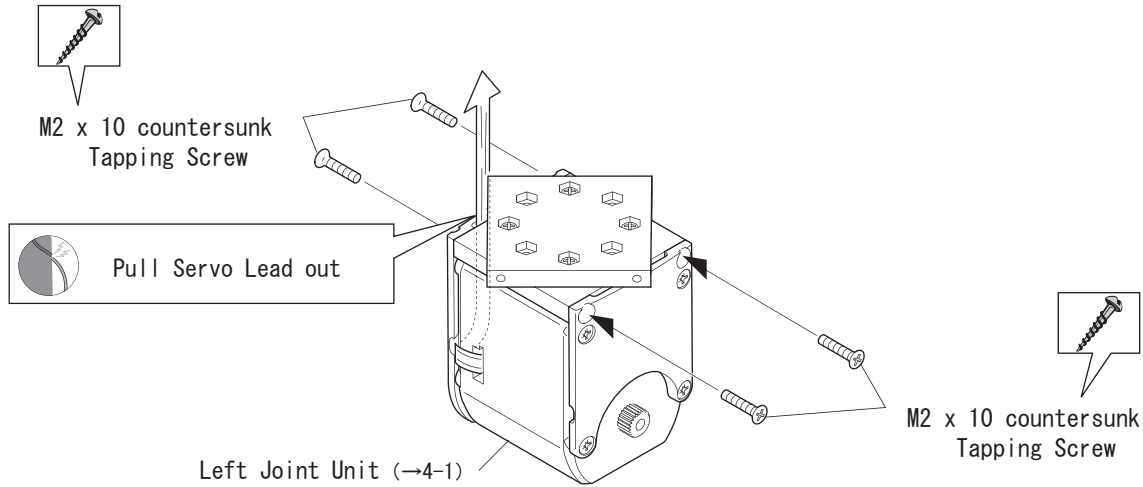

アイコン解説

-  注意
-  ポイント
-  締め込み注意
-  方向注意
-  組み立て順番
-  挟み込み注意

## 4-3 Assembling of Left Upper Arm

Parts/Units from previous operation/step

「CH3」 Servo Motor (→ 2-4)

“Left Elbow”Unit (→ 4-2)

New Parts for this step

[5] Front Arm Flame x 1

[6] Rear Arm Flame x 1

[7] Arm Side Cover x 1

M2 x 16 countersunk Machine Screw x 4

M2 x 10 countersunk Tapping Screw x 8

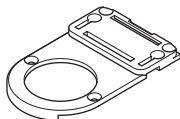

Front Arm Flame

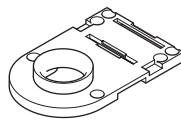

Rear Arm Flame

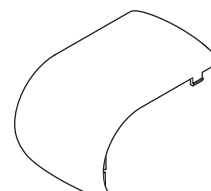

Arm Side Cover

1

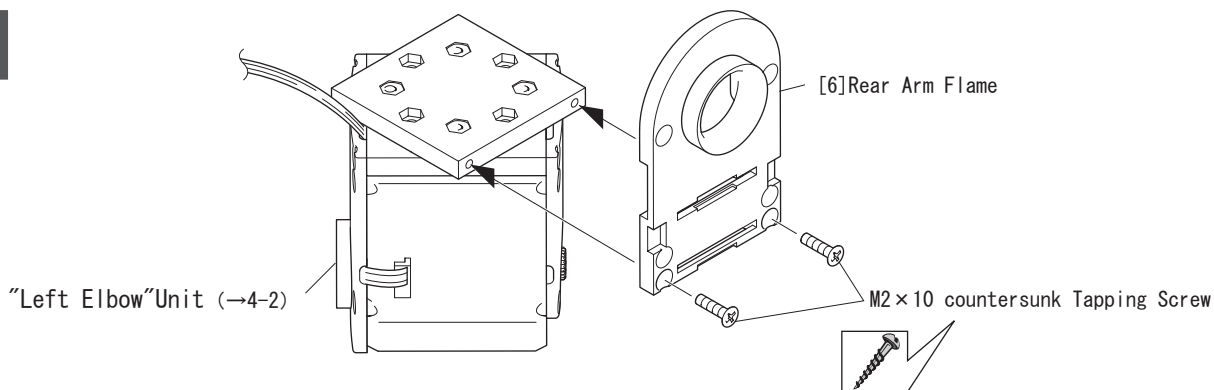

### アイコン解説



注意



ポイント



締め込み注意



方向注意

組み立て順番



挟み込み注意

2

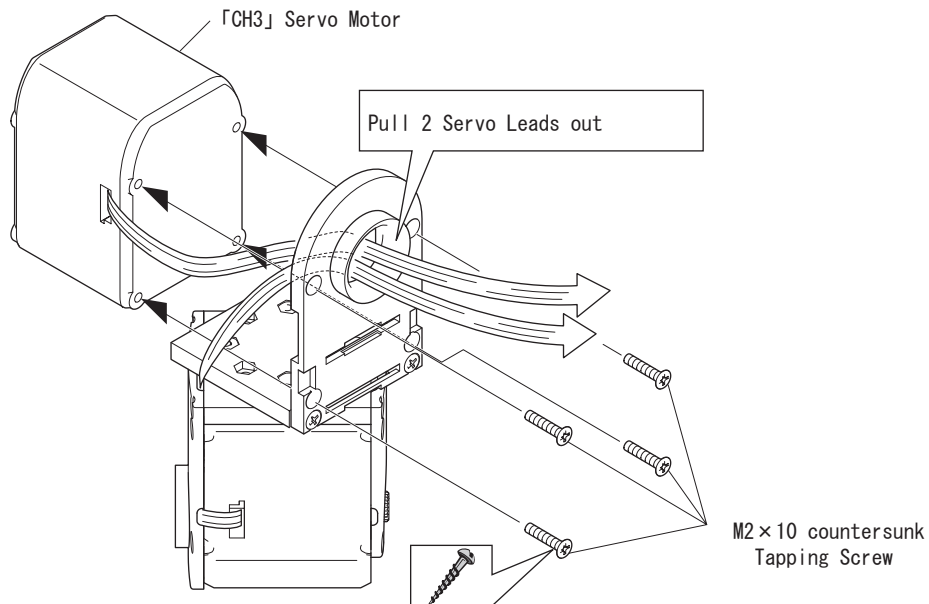

3

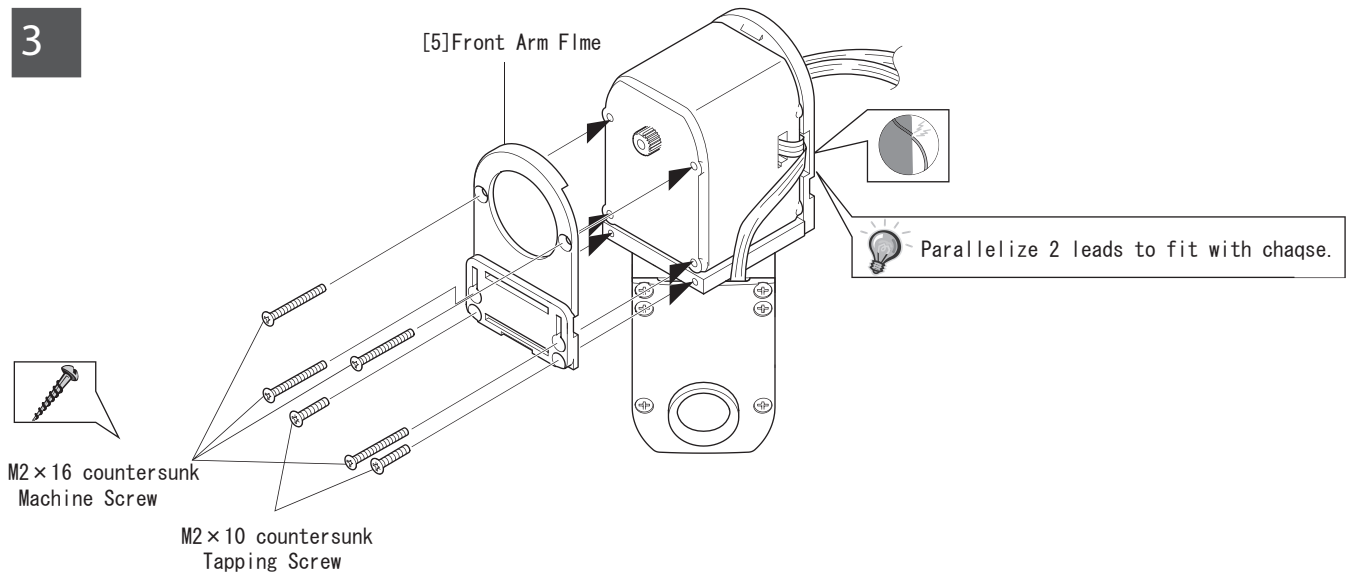

4

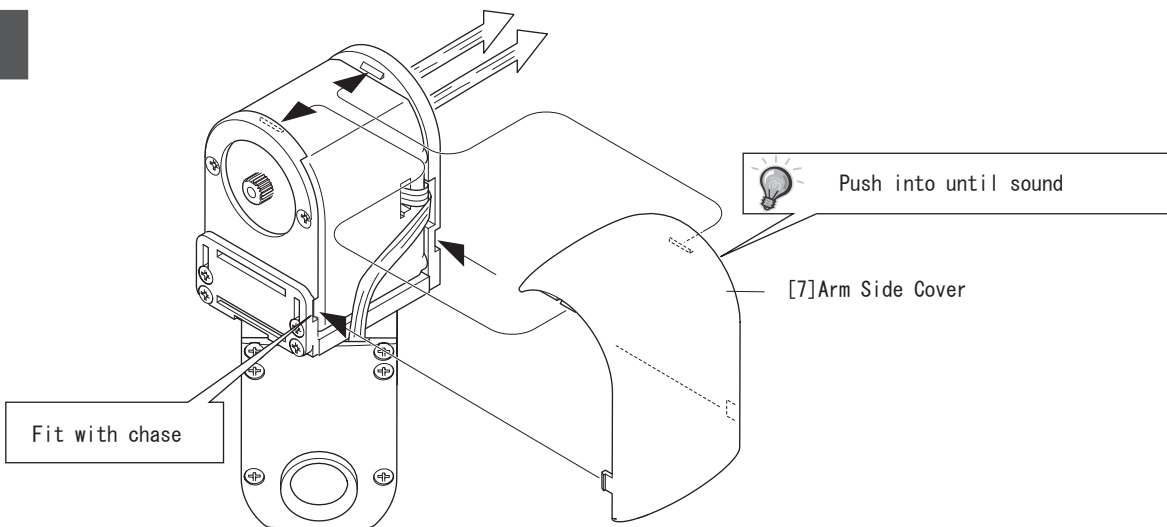

アイコン解説



注意



ポイント



締め込み注意



◀ [A] 方向注意

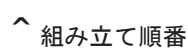

↑ 組み立て順番



挟み込み注意

## 4-4 Assembling Left Hand

Parts/Units from previous operation/step

"Right Elbow+Right Upper Arm" Unit (→3-3)

New Parts for this step

[73] Low Height Servo Horn x 1

[8] Front Hand Right x 1

[9] Rear Hand Right x 1

M2 x 5 countersunk Tapping Screw x 4

M2.6 x 10 pan-head Tapping Screw x 3

M3 x 8 Bind Tapping Screw x 1

Selicon Grease



Low Height Servo Horn

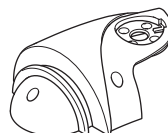

Front Hand Right

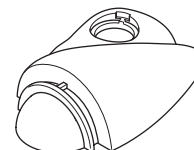

Rear Hand Right

1

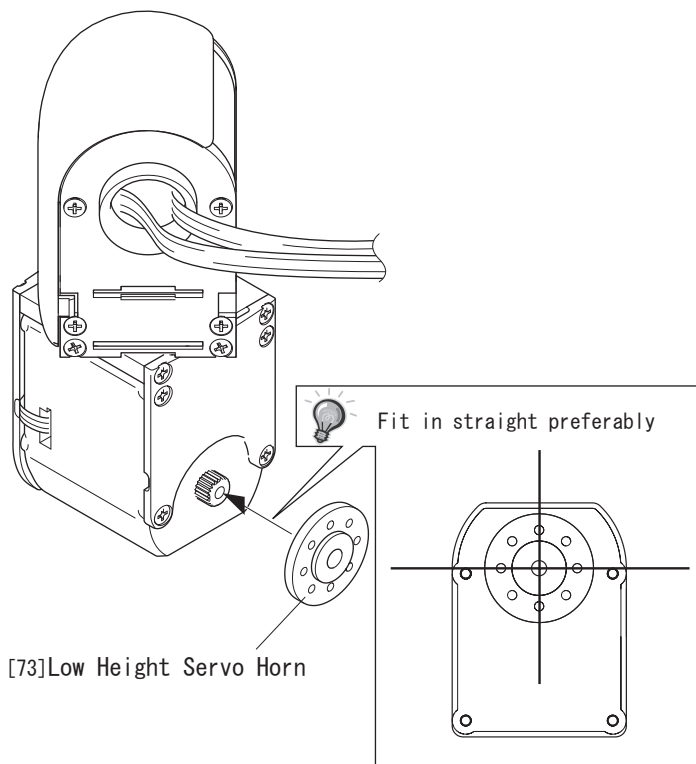

[73]Low Height Servo Horn

アイコン解説



注意



ポイント



締め込み注意

<{@喜方向注意

^組み立て順番



挟み込み注意

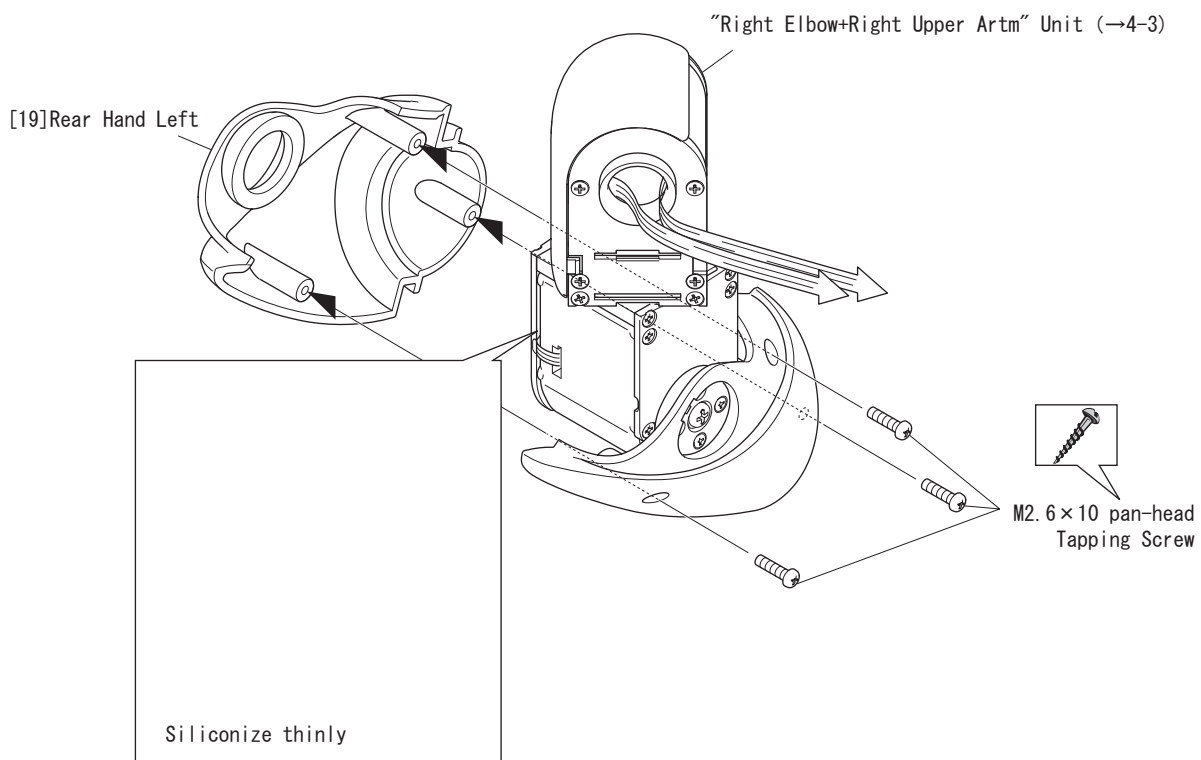
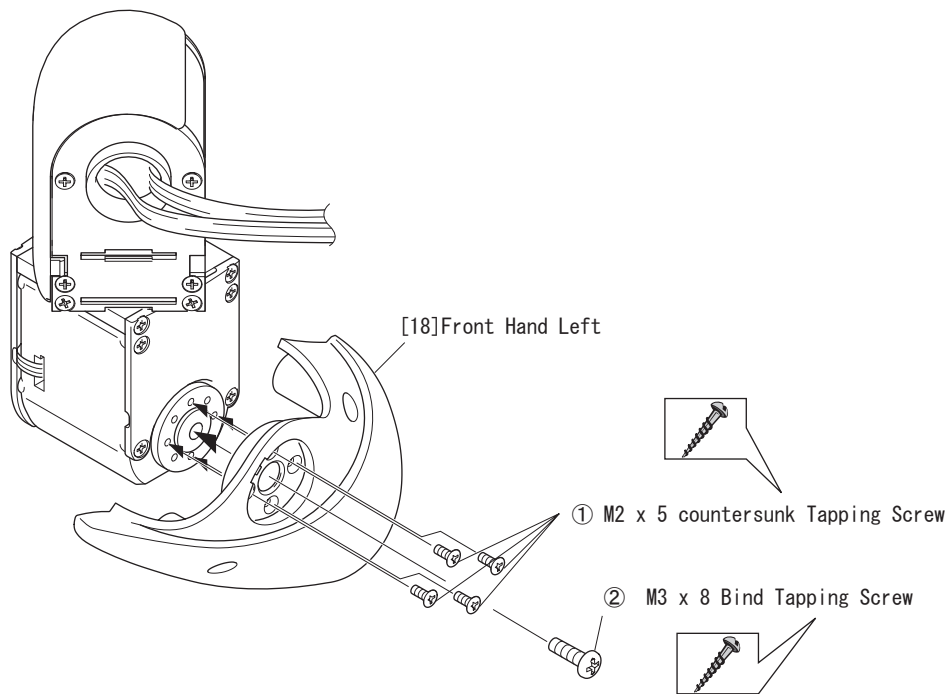

アイコン解説



注意



ポイント



締め込み注意

<{@喜方向注意



組み立て順番



挟み込み注意

## 4-5 Assembling Left Shoulder

Parts/Units from previous operation/step

「CH2」 Servo Motor (2-4)

“Left Arm” Unit (→4-4)

New Parts for this step

[73] Low Height Servo Horn x 2

[11] Front Arm Guide x 1

[12] Rear Arm Guide x 1

[13] Shoulder Base x 1

[10] Arm Base x 1

M2 x 5 countersunk Tapping Screw x 4

M2 x 20 countersunk Machine Screw x 4

M2.6 x 10 countersunk Tapping Screw x 4

M3 x 8 Bind Tapping Screw x 2



Low Height Servo Horn

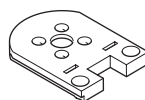

Front Arm Guide

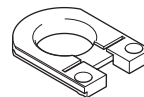

Rear Arm Guide

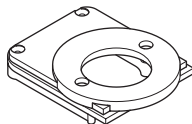

Shoulder Base

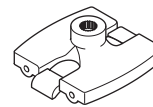

Arm Base

1

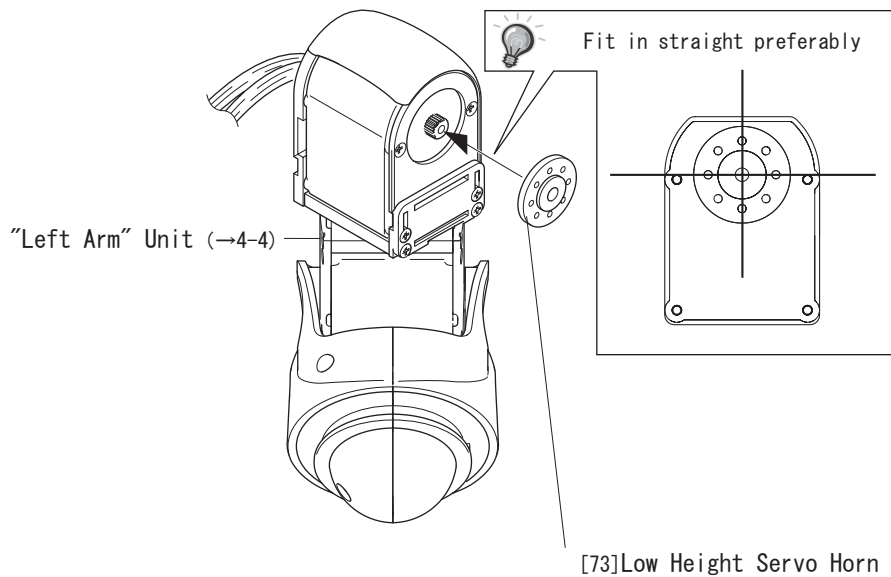

アイコン解説



注意



ポイント



締め込み注意



方向注意

組み立て順番



挟み込み注意



2

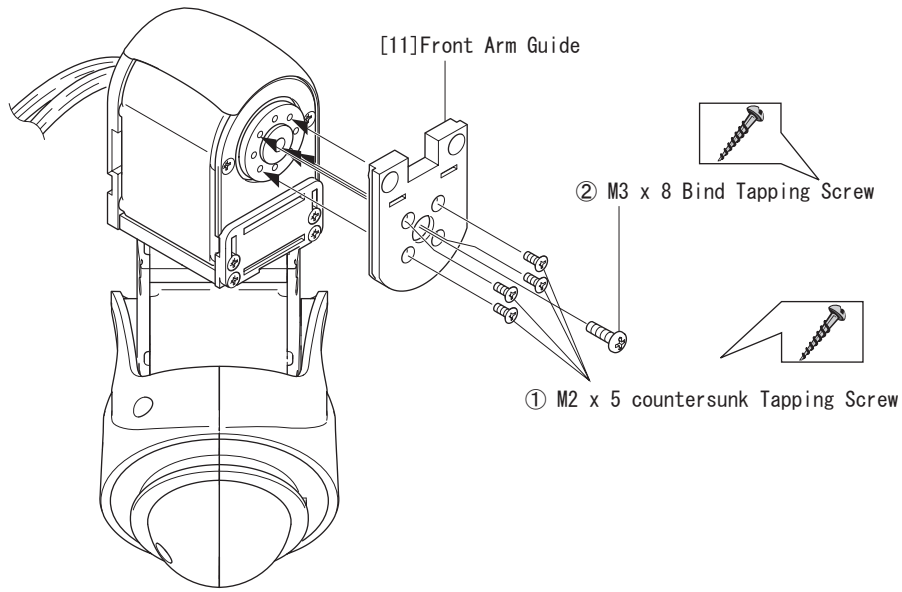

3

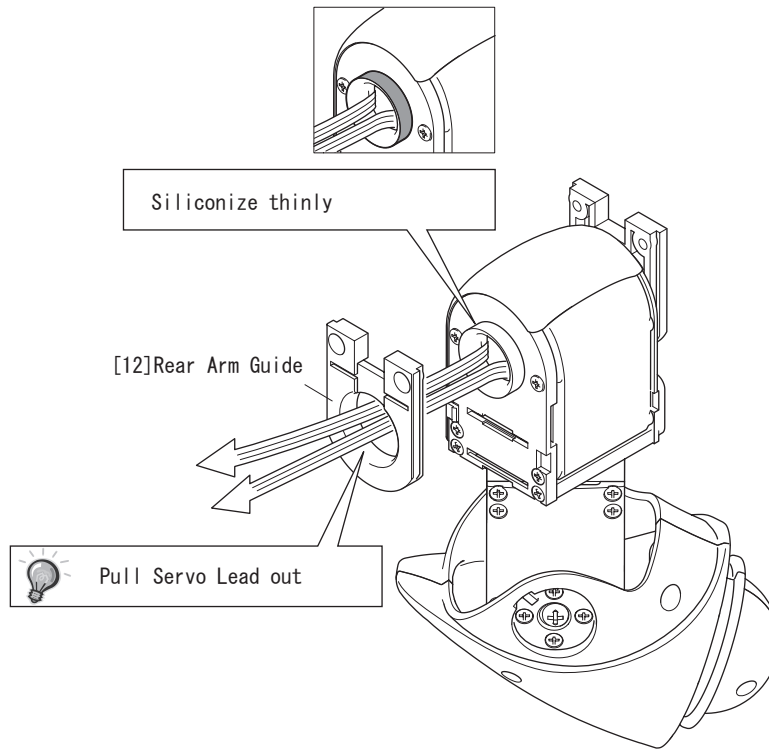

アイコン解説



注意



ポイント



締め込み注意



< { @ 方向注意

^ 組み立て順番



挟み込み注意

4

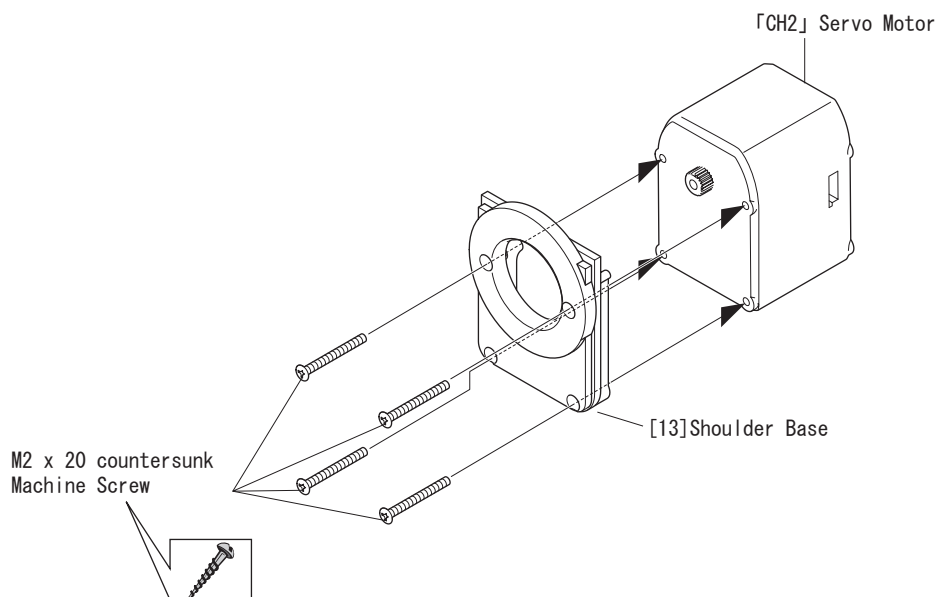

5

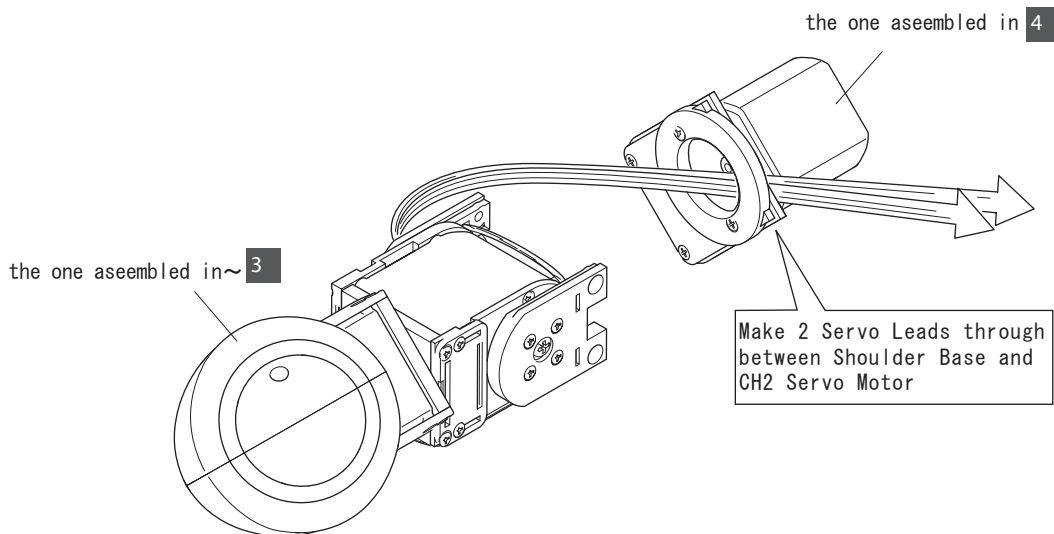

安全のための  
注意事項

付属製品に  
ついて

組み立て

ソフトウェア  
の設定

MANO  
遊び方

オプションパー  
ツの取り付け

故障かなと  
思ったら

ユーザー相談  
室のご案内

用語集

パーツ販売  
リスト

展開図

アイコン解説



注意



ポイント



締め込み注意



方向注意



組み立て順番



挟み込み注意

6

② Fit Arm Base in Output Axis of 「CH2」 Servo Motor as close angle as below views.

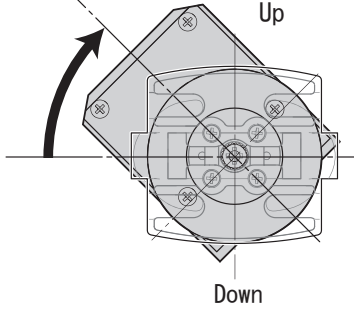

④ Pull Servo Leads lightly to avoid the leads sagging preferably \*

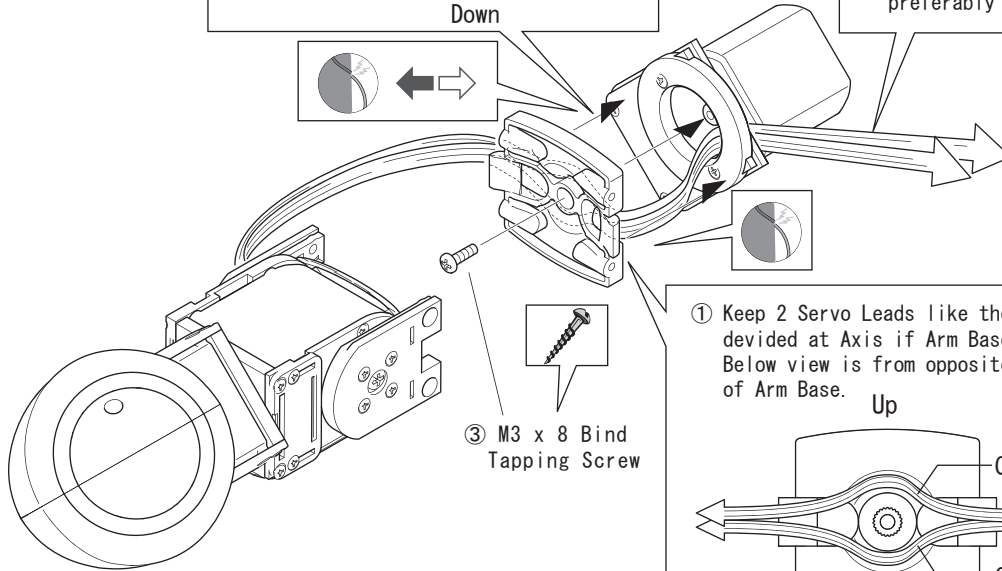

① Keep 2 Servo Leads like they are divided at Axis if Arm Base. Below view is from opposite side of Arm Base.

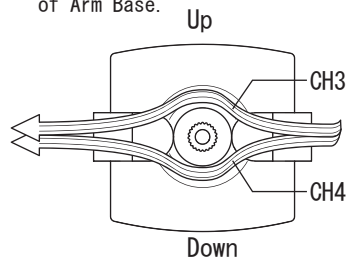

7

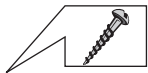

M2.6 x 10 countersunk Tapping Screw

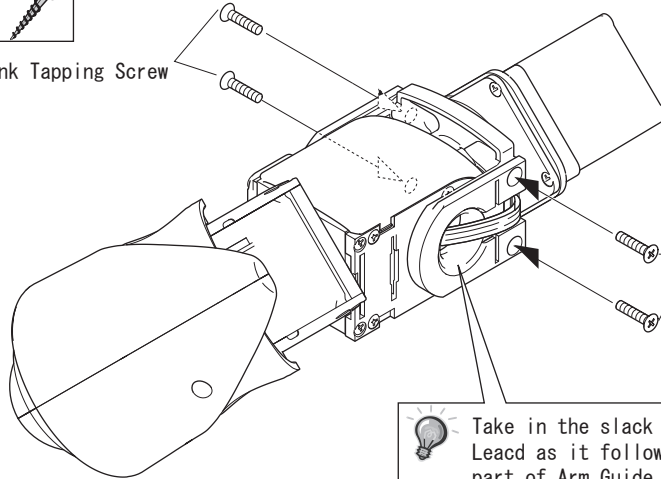

M2.6 x 10 countersunk Tapping Screw



Take in the slack of Servo Lead as it follows with dent part of Arm Guide tightly as see \* of 6 for reference,

アイコン解説



注意



ポイント



締め込み注意

< { @ 喜 方向注意

^ 組み立て順番



挟み込み注意

## 4-6 Attaching Covers (Left Arm)

以前の工程から引き継ぐ部品 / ユニット

“Right Arm+Right Shoukder” Unit (→4-5)

新しく使用する部品

- [14] Arm Cover x 2
- [15] Arm Screw Cover x 2
- [16] Hand Cap x 2
- [20] Knuckle Right

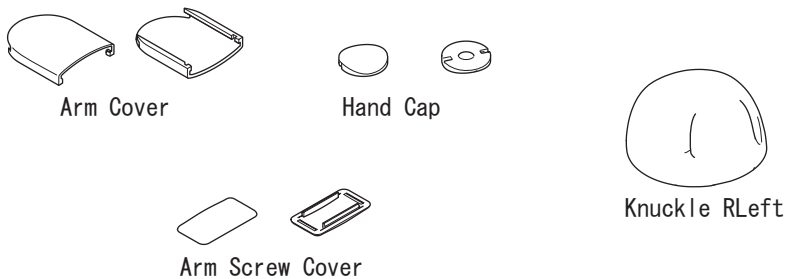

1

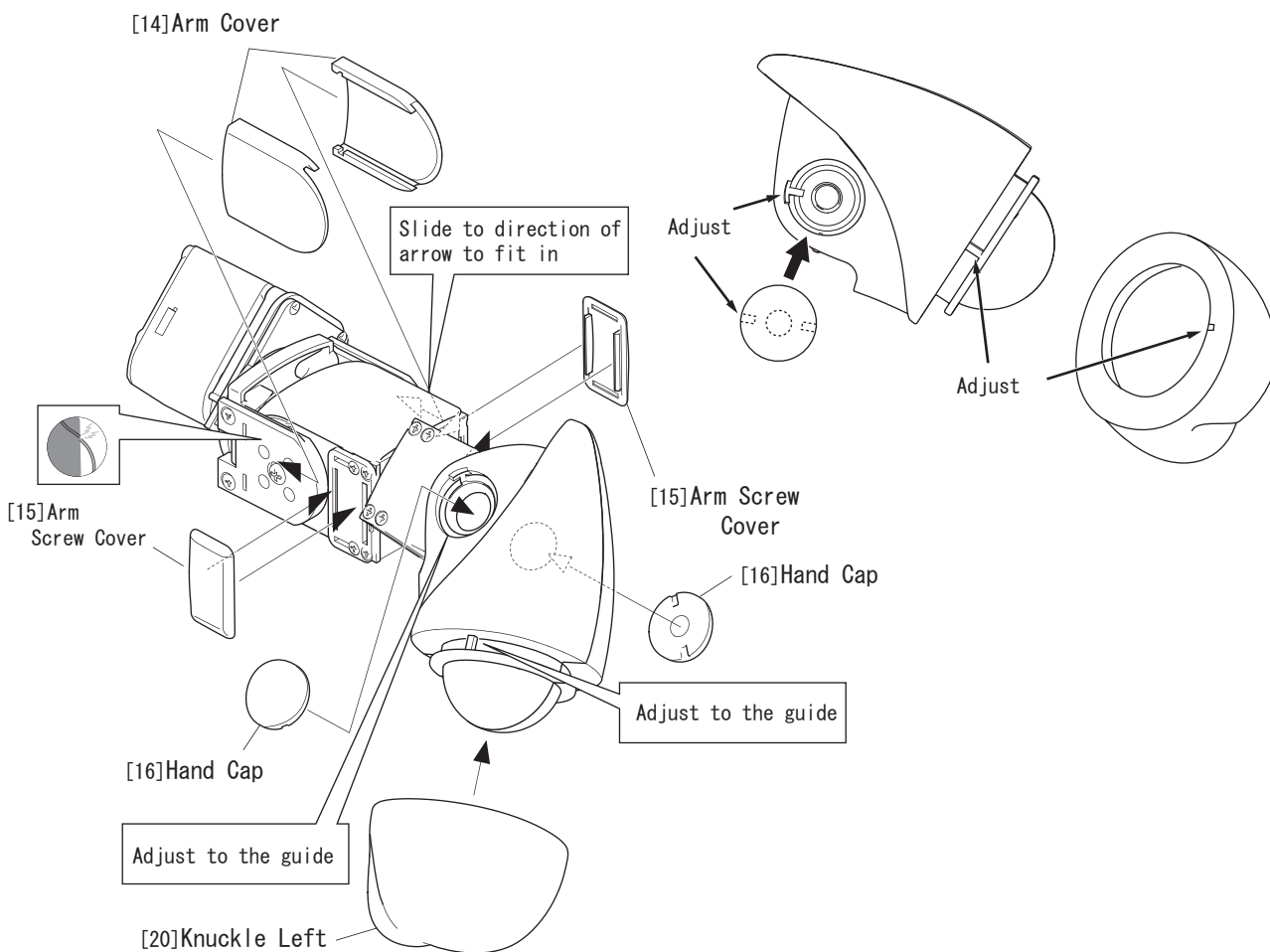

アイコン解説



注意



ポイント



締め込み注意



<

{

①

方向注意



組み立て順番



挟み込み注意

## 4-7 Operation 4 Final Drawing

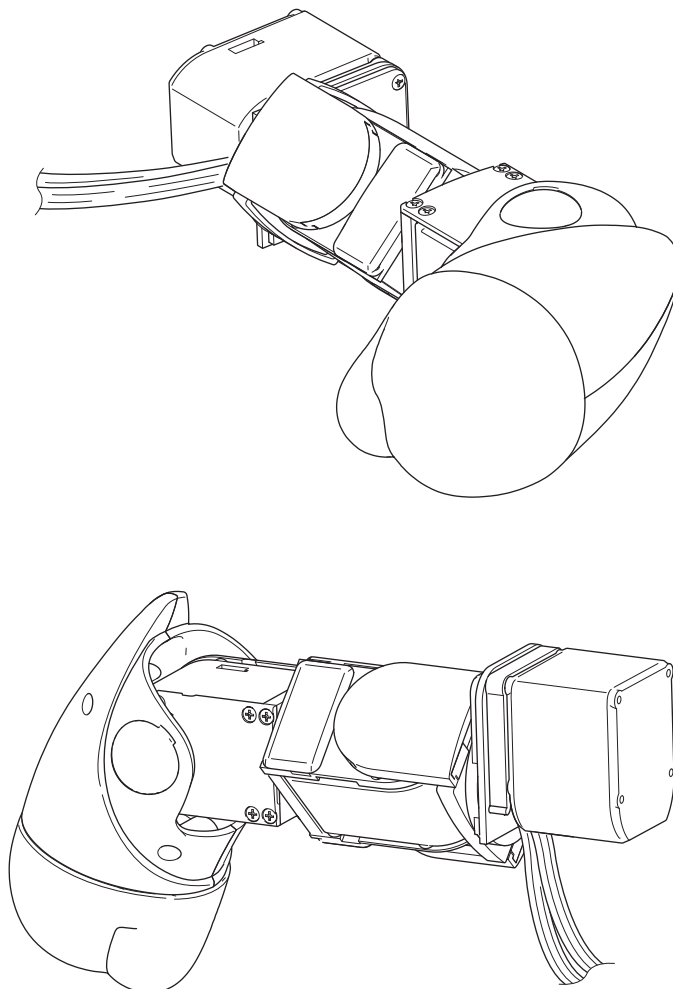

### アイコン解説



注意



ポイント



締め込み注意

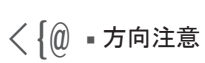

方向注意



組み立て順番



挟み込み注意

# 工程 05 Assembling Right Leg (Pack 5)

## 5-1 Assembling Right Ankle

Parts/Units from previous operation/step

「CH14」 Servo Motor (→ 2-4)

「CH15」 Servo Motor (→ 2-4)

New Parts for this step

[73] Low Height Servo Horn x 1

[21] Middle Ankle x 1

[22] Side Ankle x 1

[23] Front Ankle(Right) x 1

[24] Rear Ankle x 1

[25] Rear Ankle Joint(Right) x 1

[26] Front Ankle Joint(Right) x 1

[27] Shoe(Right) x 1

[28] Sole (Right) x 1

N2 x 5 countersunk Tapping Screw x 10

M2 x 10 countersunk Tapping Screw x 4

M2 x 16 countersunk Machine Screw x 10

M2.6 x 8 pan-head Tapping Screw x 2

M2.6 x 10 countersunk Tapping Screw x 4

M3 x 8 Bind Tapping Screw x 1



Low Height Servo Horn

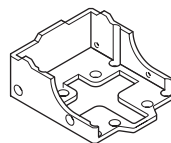

Middle Ankle

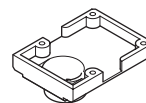

Side Ankle

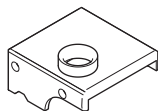

Front Ankle(Right)

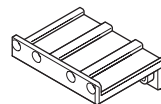

Rear Ankle

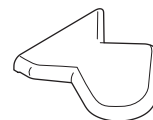

Front Ankle Joint  
(Right)

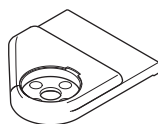

Rear Ankle Joint(Right)

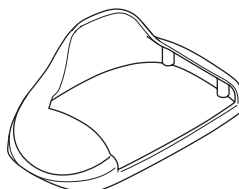

Shoe (Right)

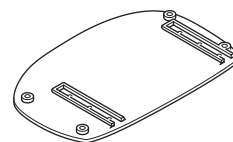

Sole (Right)

アイコン解説



注意



ポイント



締め込み注意

< @ 方向注意

^ 組み立て順番



挟み込み注意

安全のための  
注意事項

付属製品に  
ついて

組み立て

ソフトウェア  
の設定

MANUAL  
遊び方

での

オプションパー  
ツの取り付け

故障かなと  
思ったら

ユーザー相談  
室のご案内

用語集

パーツ販売  
リスト

展開図

1

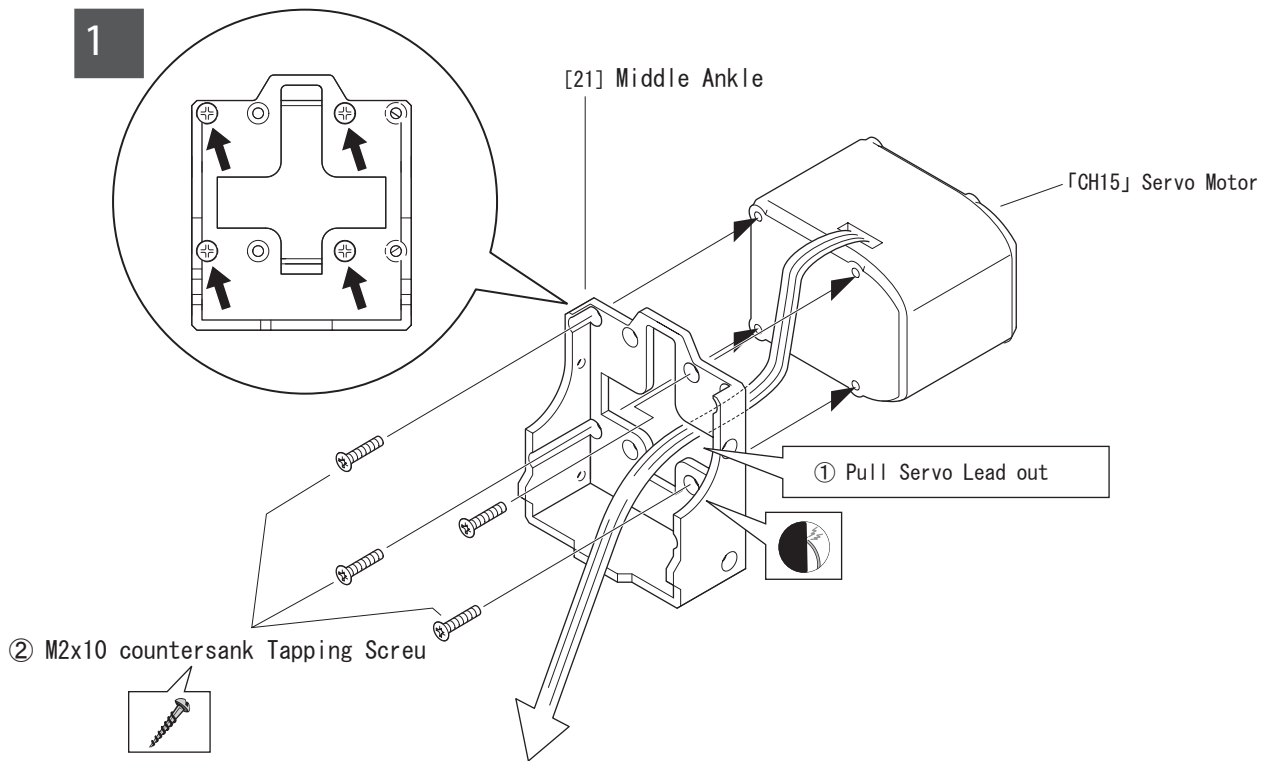

2

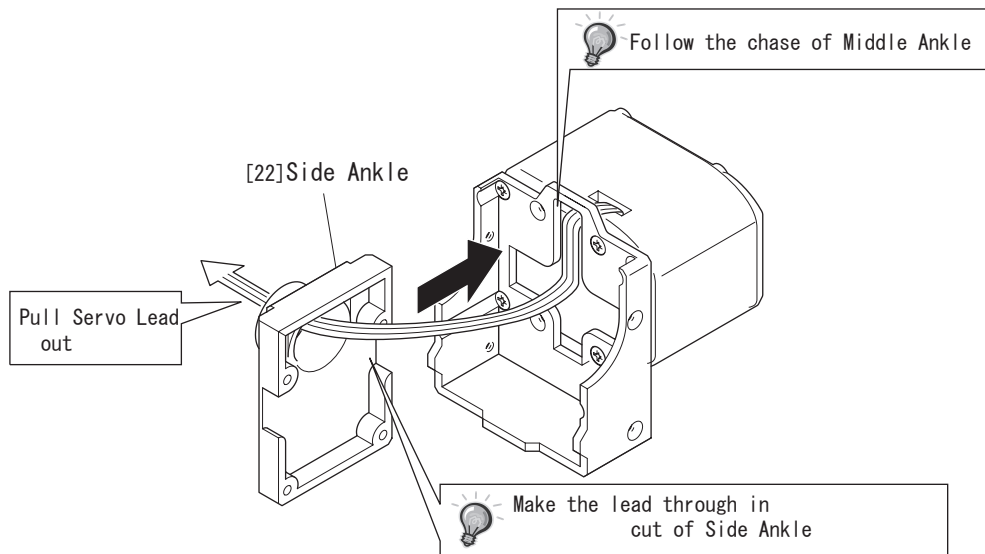

アイコン解説



注意



ポイント



締め込み注意

<{@滑方向注意

^ 組み立て順番



挟み込み注意



3

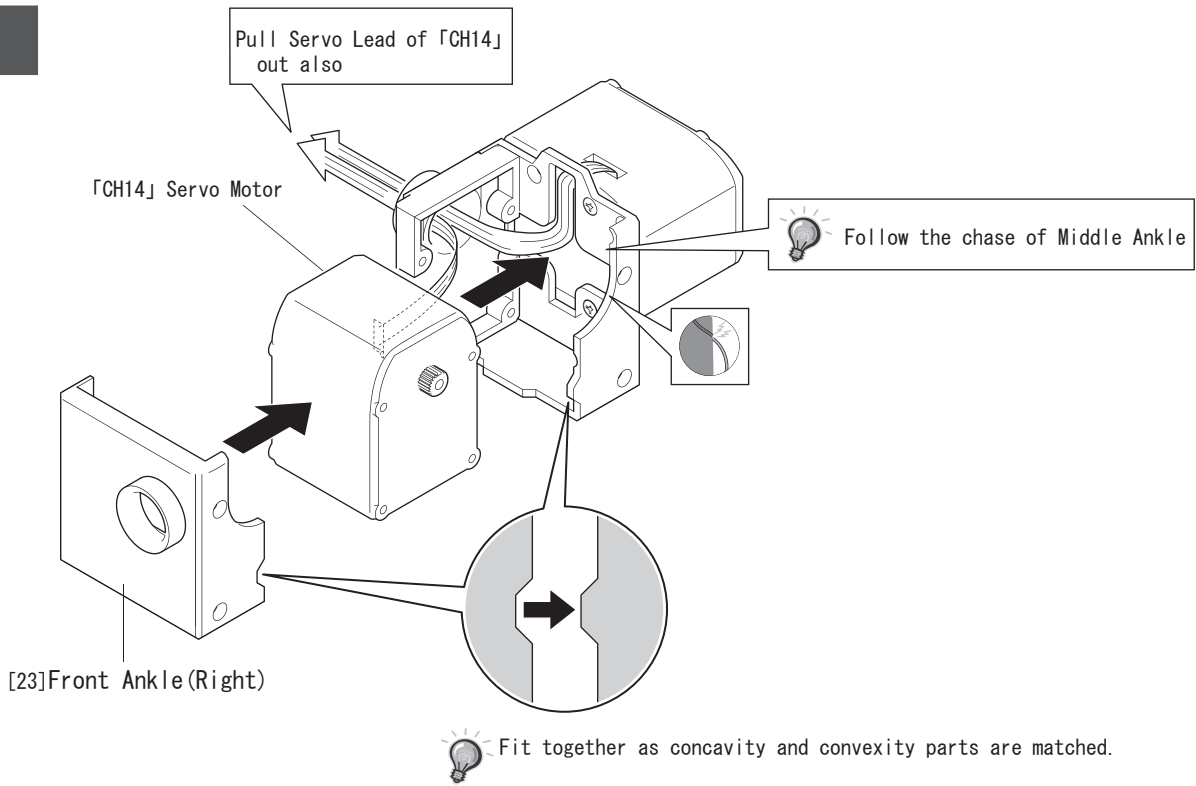

4

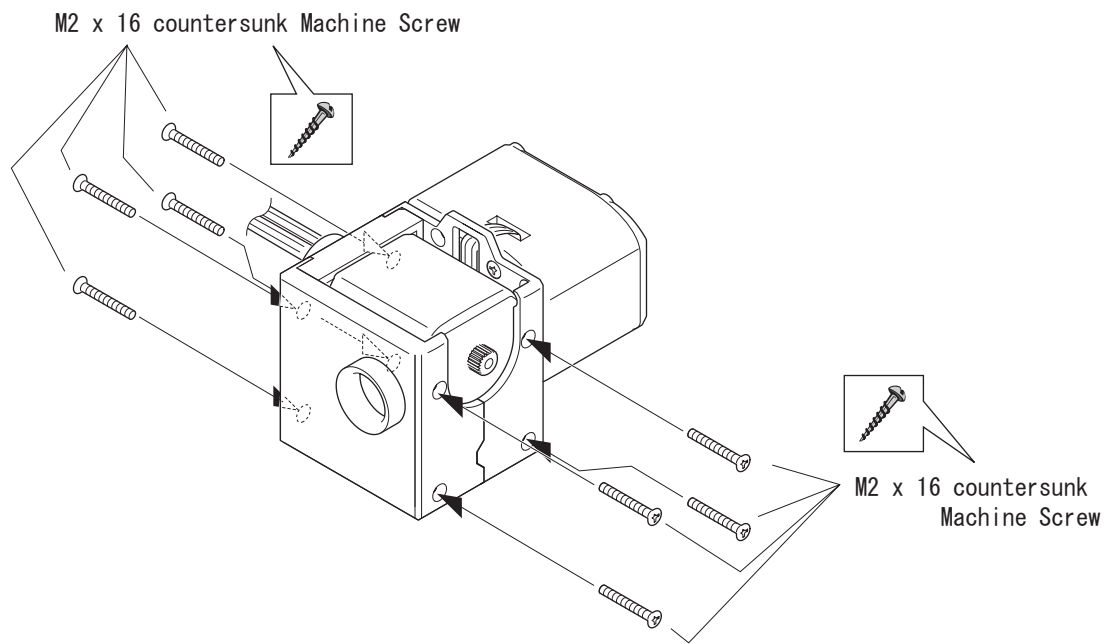

アイコン解説



注意



ポイント



締め込み注意



方向注意

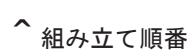

組み立て順番



挟み込み注意

安全のための  
注意事項

付属製品に  
ついて

組み立て

ソフトウェア  
の設定

MANO  
遊び方  
での

オプションパー  
ツの取り付け

故障かなと  
思ったら

ユーザー相談  
室のご案内

用語集

パーツ販売  
リスト

展開図

5

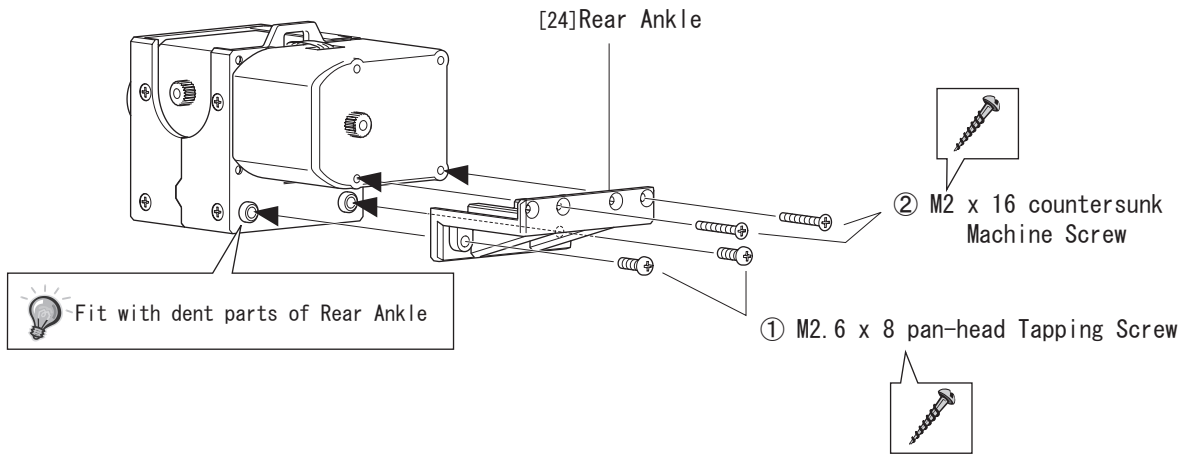

6

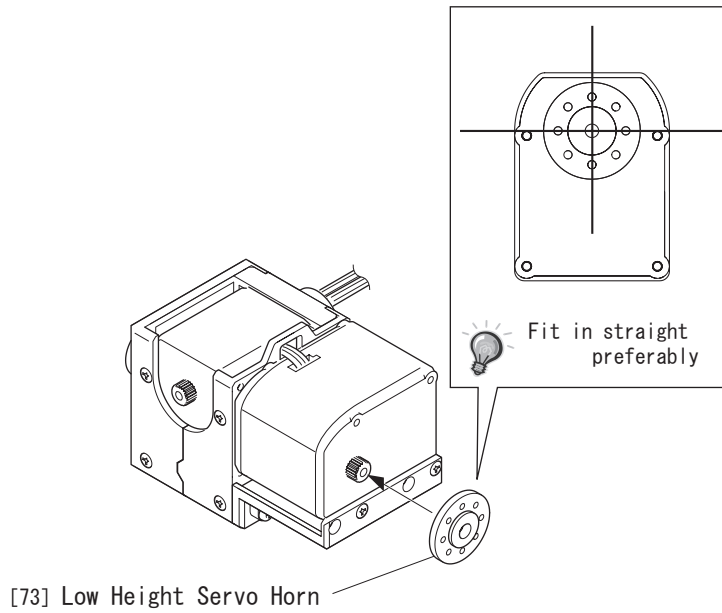

7

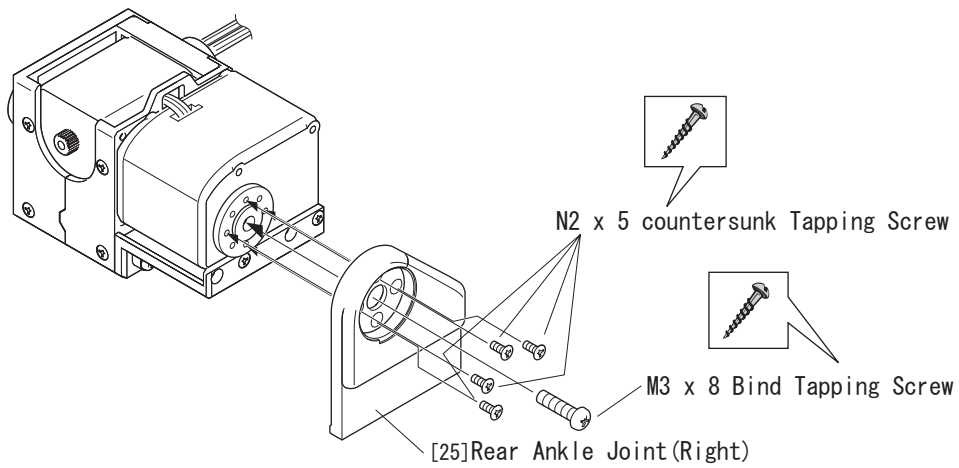

アイコン解説



注意



ポイント



締め込み注意

< { @ 方向注意

^ 組み立て順番



挟み込み注意

8

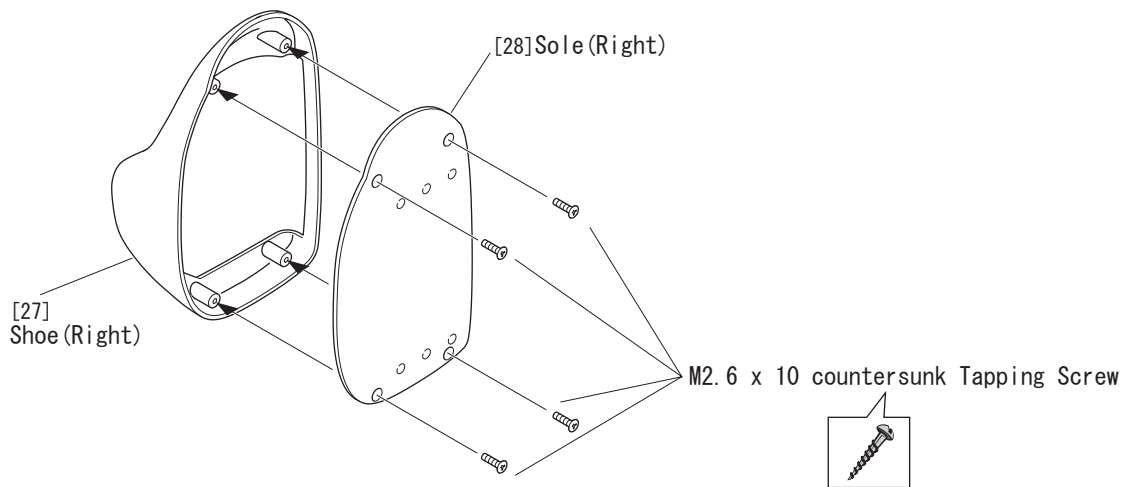

9

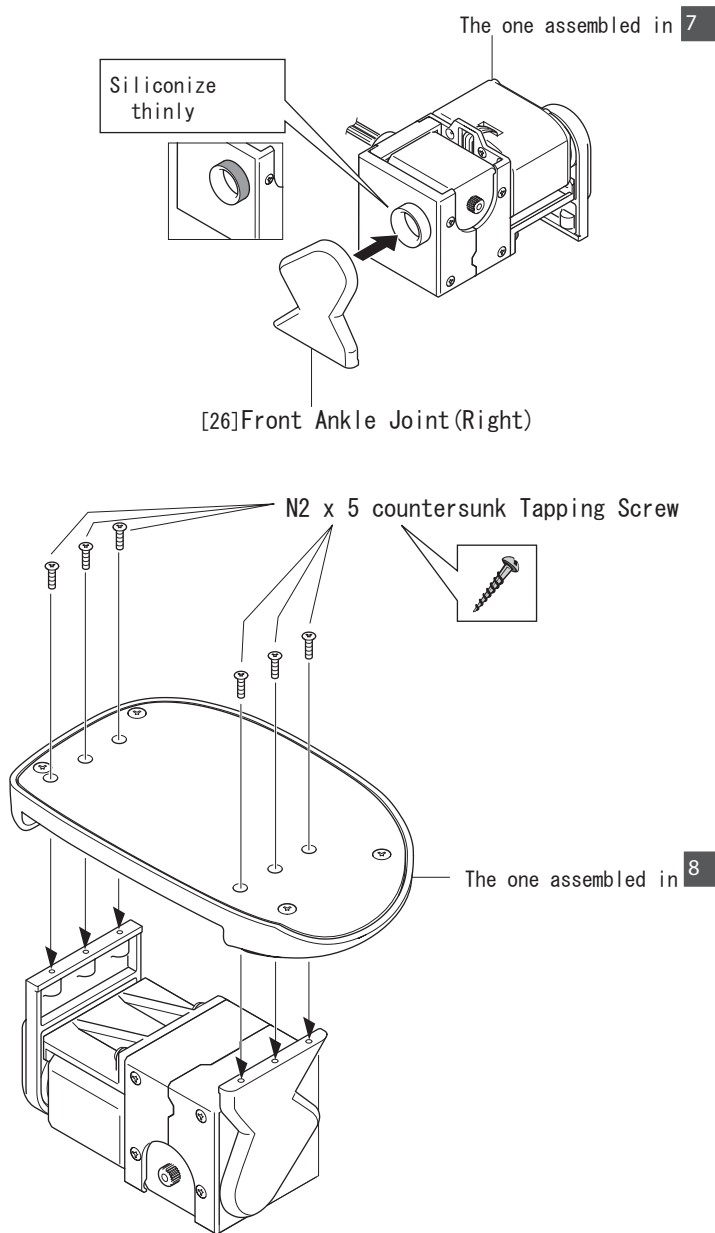

安全のための  
注意事項

付属製品に  
ついて

組み立て

ソフトウェア  
の設定

MANO  
遊び方

での

オプションパー  
ツの取り付け

故障かなと  
思ったら

ユーザー相談  
室のご案内

用語集

パーツ販売  
リスト

展開図

アイコン解説



注意



ポイント



締め込み注意



方向注意



組み立て順番



挟み込み注意

## 5-2 Assembling of Outside of Right Leg

Parts/Units from previous operation/step

"Right Ankle" Unit (→5-1)

New Parts for this step

- [29] Outside Knee (Right) x 1
- [30] Knee Cover (Right) x 1
- [31] Knee Stay x 1
- [32] Thigh Flame x 1
- M2 x 5 pan-head Tapping Screw x 4
- M2 x 8 pan-head Tapping Screw x 3

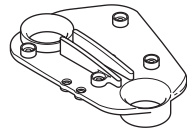

Outside Knee (Right)

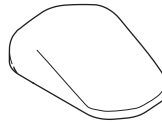

Knee Cover (Right)

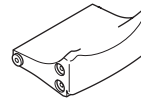

Knee Stay

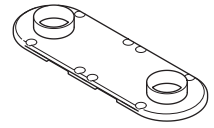

Thigh Flame

1

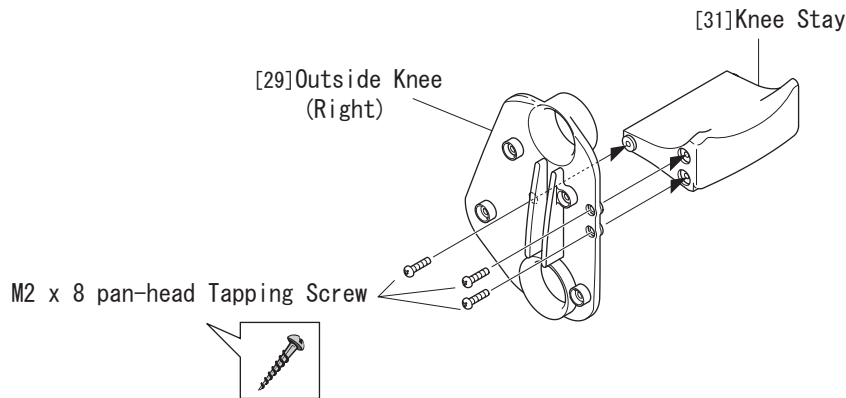

2

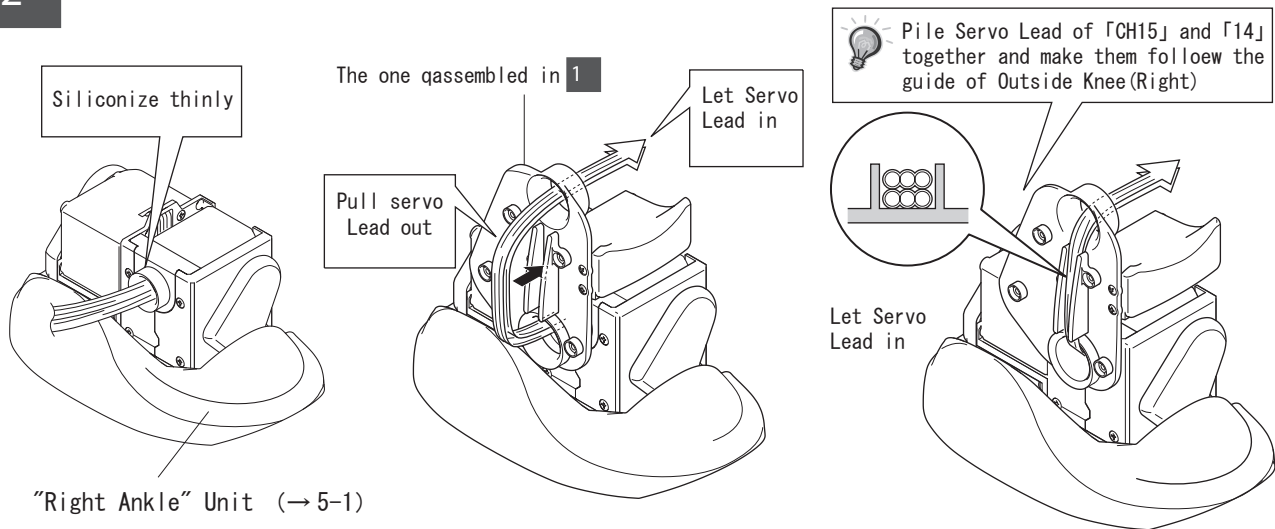

アイコン解説



注意



ポイント



締め込み注意

< @顎方向注意

^ 組み立て順番



挟み込み注意

3

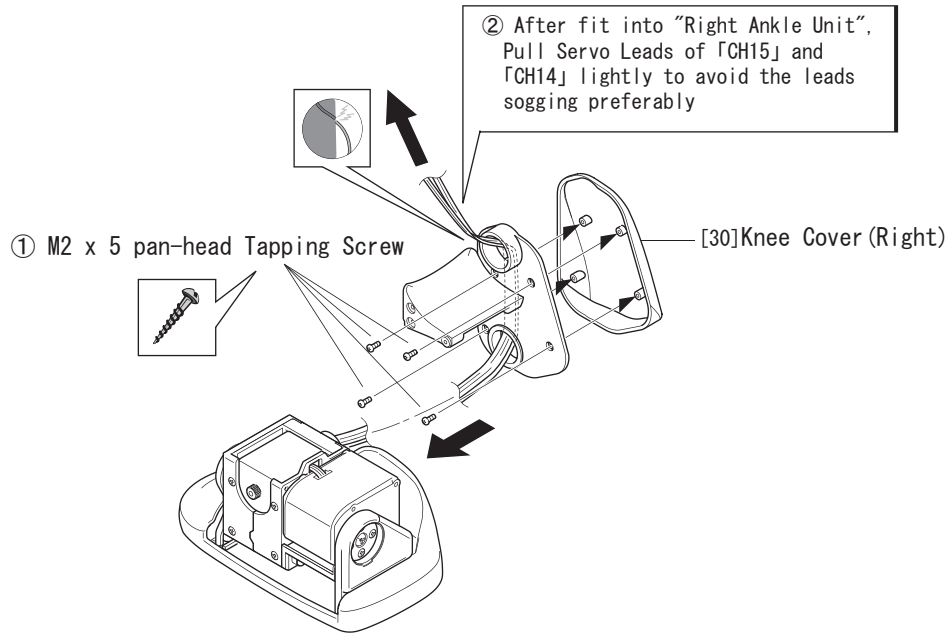

4

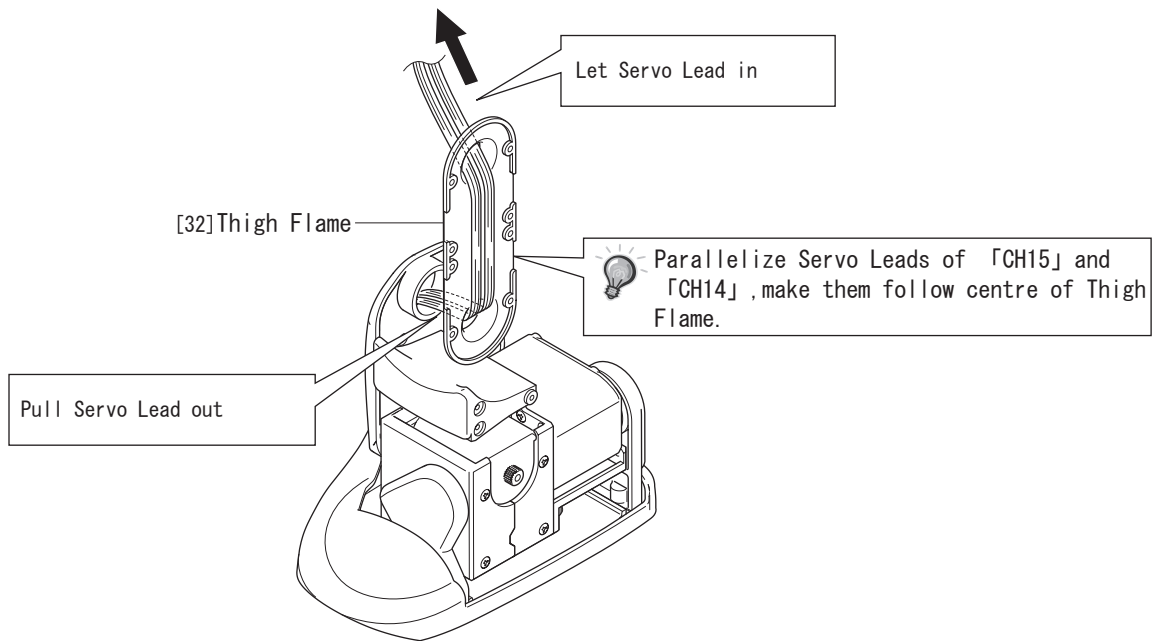

安全のための  
注意事項

付属製品に  
ついて

組み立て

ソフトウェア  
の設定

MANO-  
遊び方

での

オプションパー  
ツの取り付け

故障かなと  
思ったら

ユーザー相談  
室のご案内

用語集

パーツ販売  
リスト

展開図

アイコン解説



注意



ポイント



締め込み注意



方向注意



組み立て順番



挟み込み注意

## 5-3 Assembling of Inside of Right Leg

Parts/Units from previous operation/step

"Right Ankle"+"Outside of Right Leg" Unit (→5-2)  
「CH12」 Servo Motor (→ 2-4)

「CH13」 Servo Motor (→ 2-4)

New Parts for this step

[73] Low Height Servo Horn x 3

[33] Inside Knee(Right) x 1

[34] Front Thigh Cover(Right) x 1

[35] Rear Thigh Cover(Right) x 1

M2 x 5 pan-head Tapping Screw x 8

M2 x 10 countresunk Tapping Screw x 8

M2 x 16 countresunk Machine Screw x 8

M3 x 8 Bind Tapping Screw x 2

M2 x 8 pan-head Tapping Sfcrow x 7



Low Height  
Servo Horn

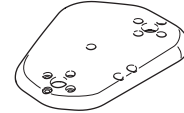

Inside Knee(Right)



Front Thigh  
Cover (Right)



Rear Thigh  
Cover (Right)

1

② M2 x 10 countresunk Tapping Screw

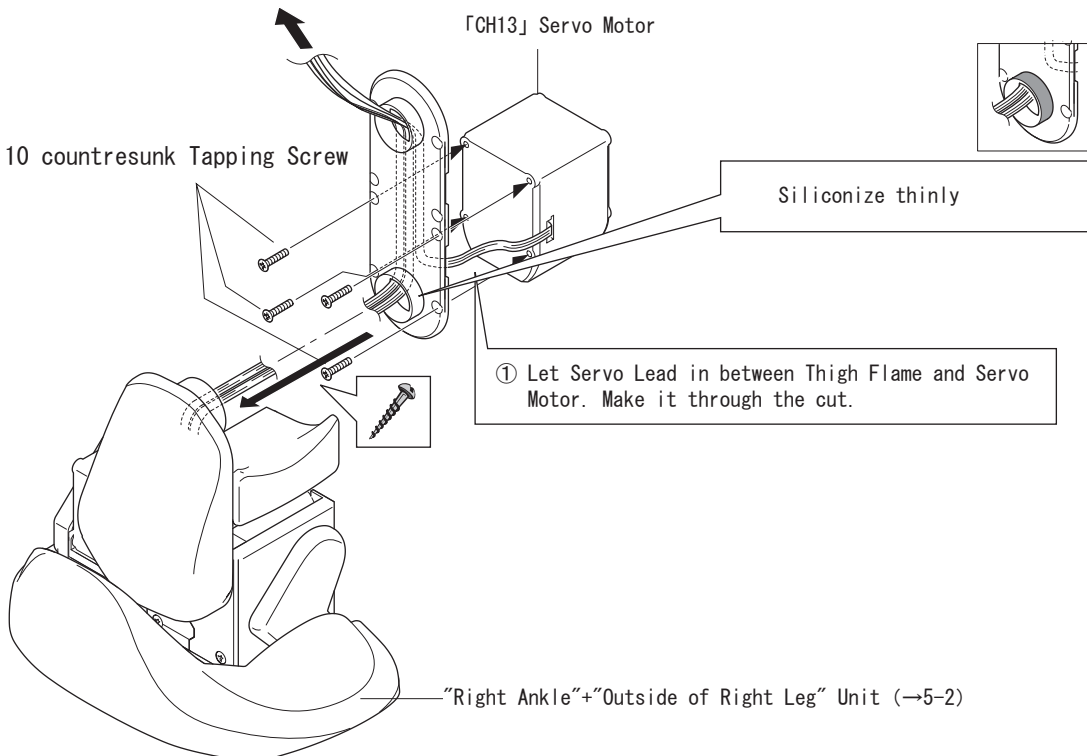

アイコン解説



注意



ポイント



締め込み注意

<[@喜方向注意

^組み立て順番



挟み込み注意

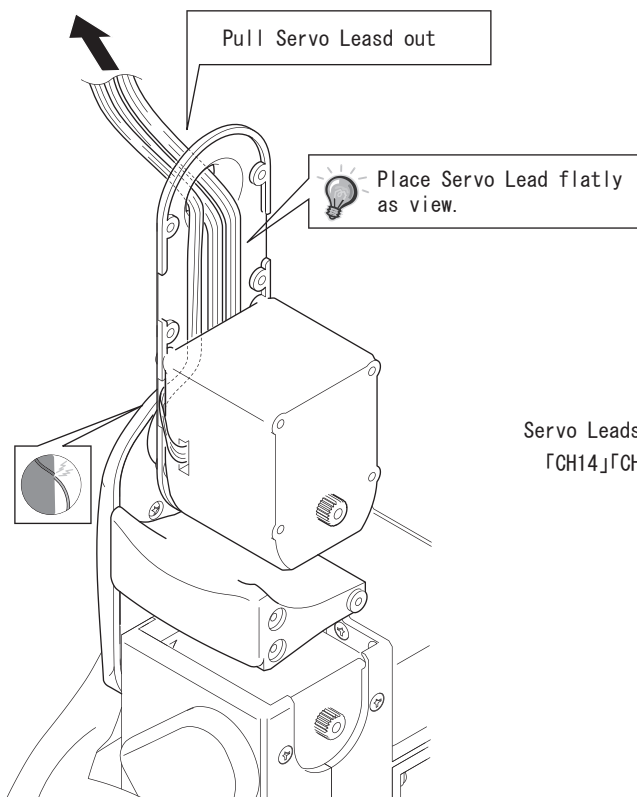

reference drawing of placement  
\*sight from upper side of the left view

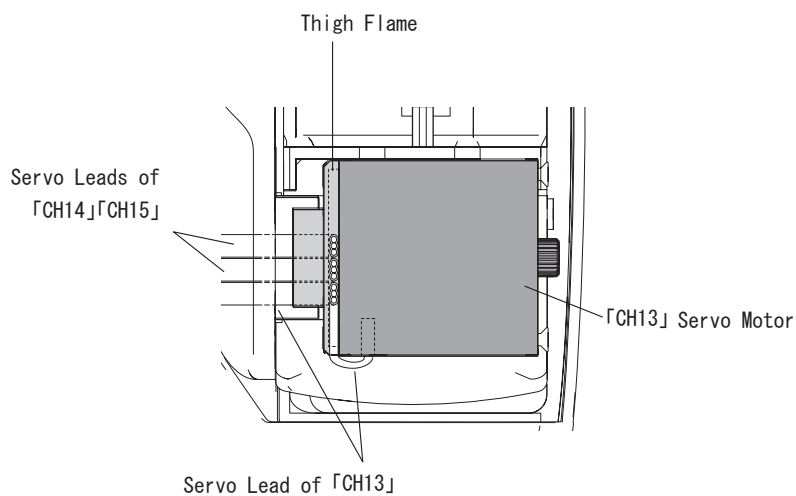

2

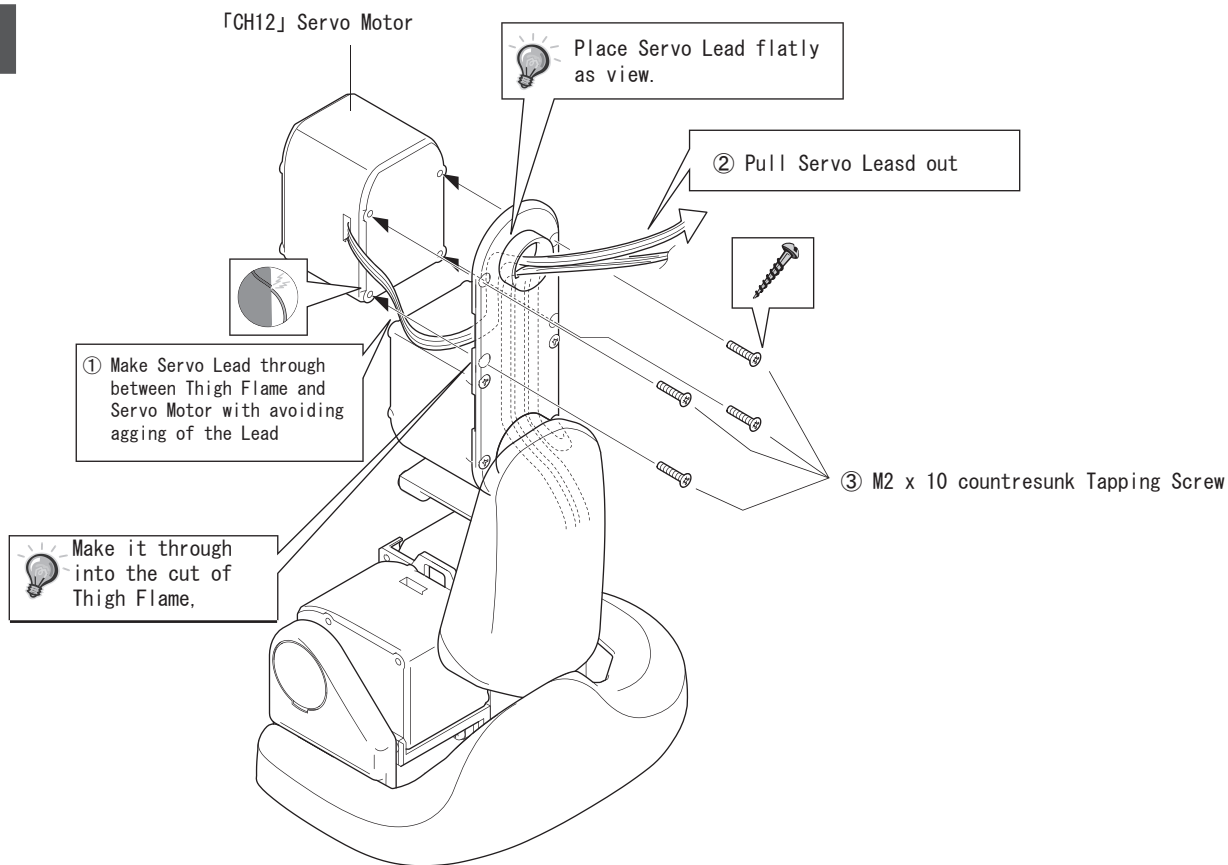

アイコン解説



注意



ポイント



締め込み注意

< { @ 喜 方向注意

^ 組み立て順番



挟み込み注意

3

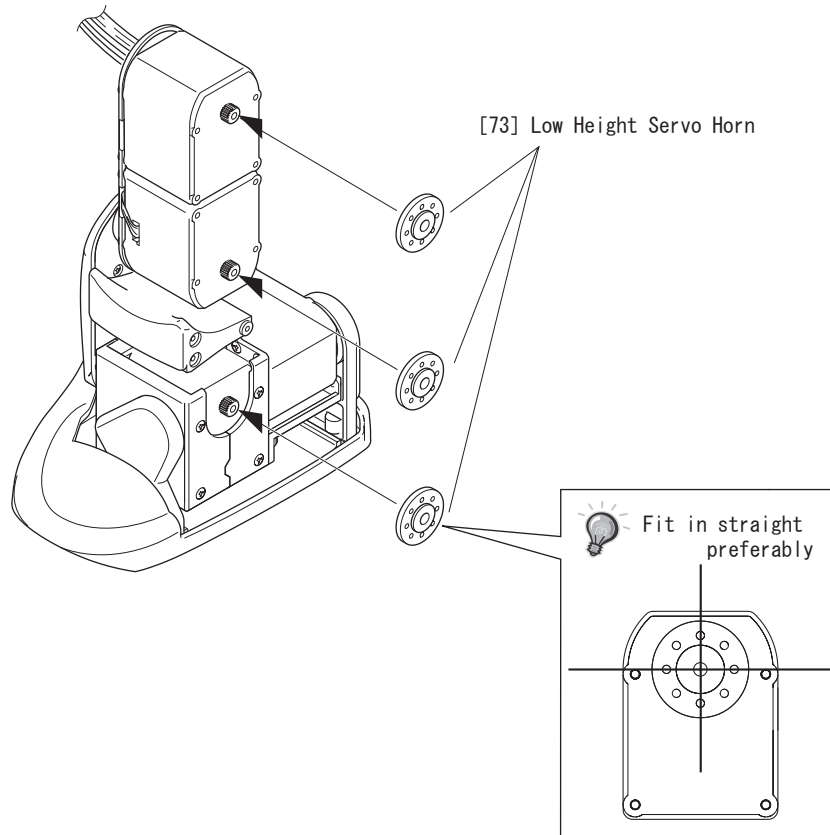

4

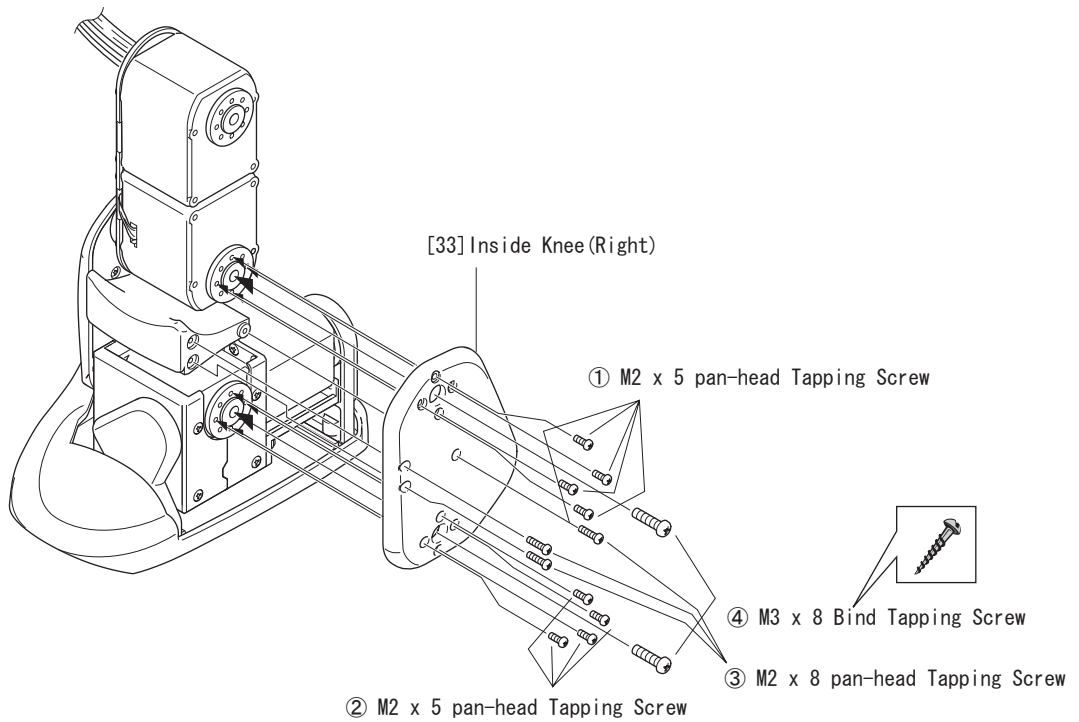

アイコン解説



注意



ポイント



締め込み注意

< { @ 質 方向注意

^ 組み立て順番



挟み込み注意



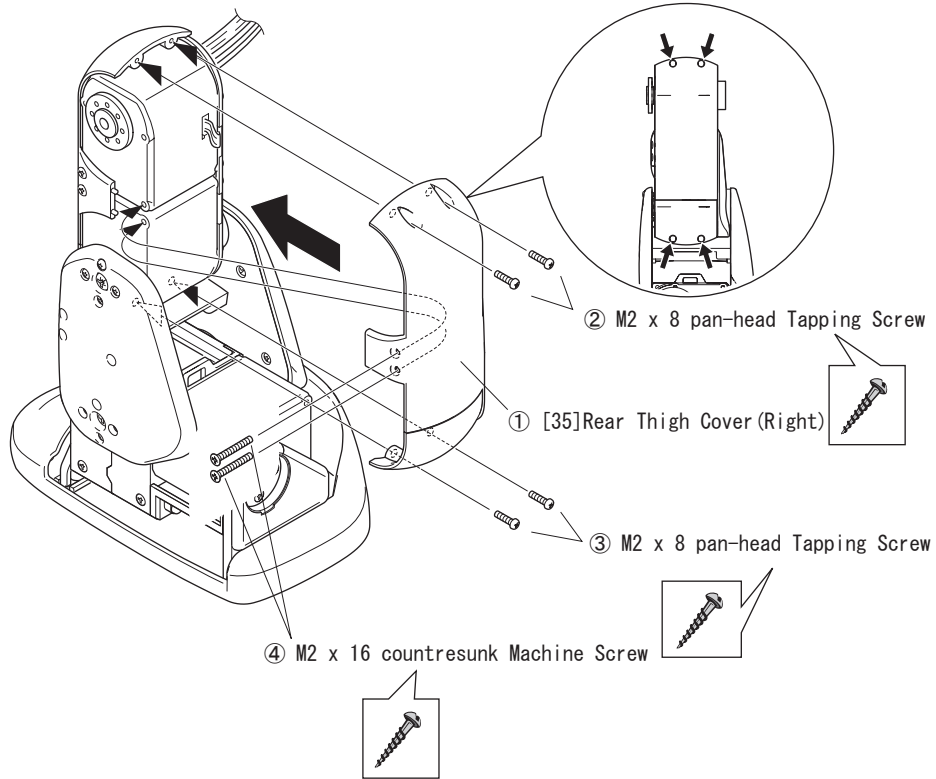
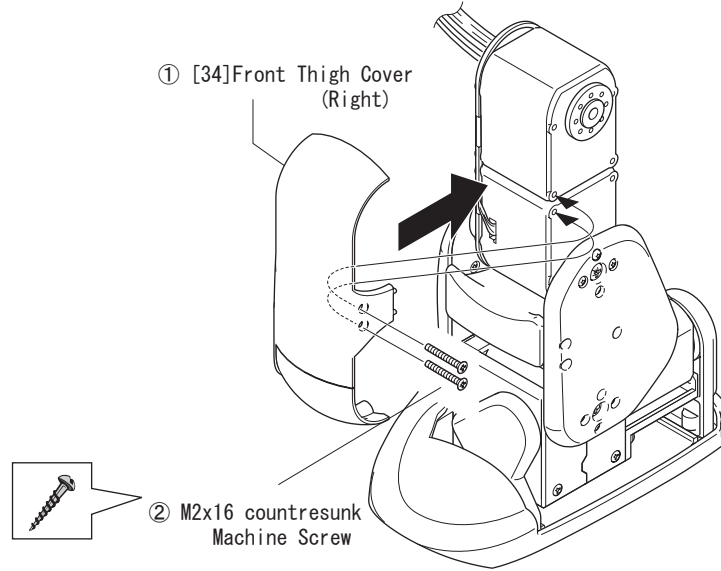

アイコン解説



注意



ポイント



締め込み注意



← @ 方向注意



^ 組み立て順番



挟み込み注意

## 5-4 Assembling of Right Hip

Parts/Units from previous operation/step

"Right Leg" Unit (→ 5-3)

「CH11」 Servo Motor (→ 2-4)

New Parts for this step

- [73] Low Height Servo Horn x 1
- [36] Front Hip Flame(Right) x 1
- [37] Inside Hip Flame x 1
- [38] Outside Hip Flame x 1
- [39] Rear Hip Flame(Right)
- M2 x 5 countersunk Tapping Screw x 4
- M2 x 10 countersunk Tapping Screw x 4
- M2 x 16 countersunk Machine Screw x 4
- M2.6 x 10 countersunk Tapping Screw x 4
- M3 x 8 Bind Tapping Screw x 1

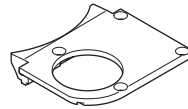

Rear Hip Flame (Right)

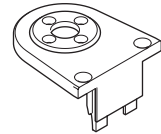

Inside Hip Flame

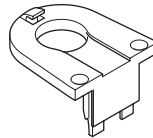

Outside Hip Flame

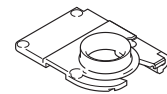

Front Hip Flame (Right)

1

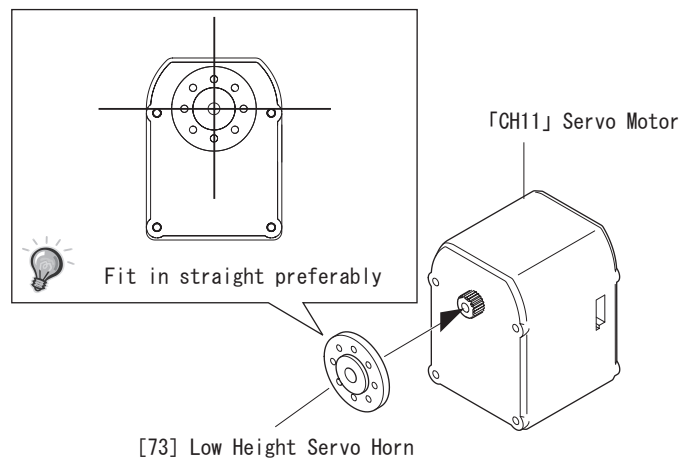

2

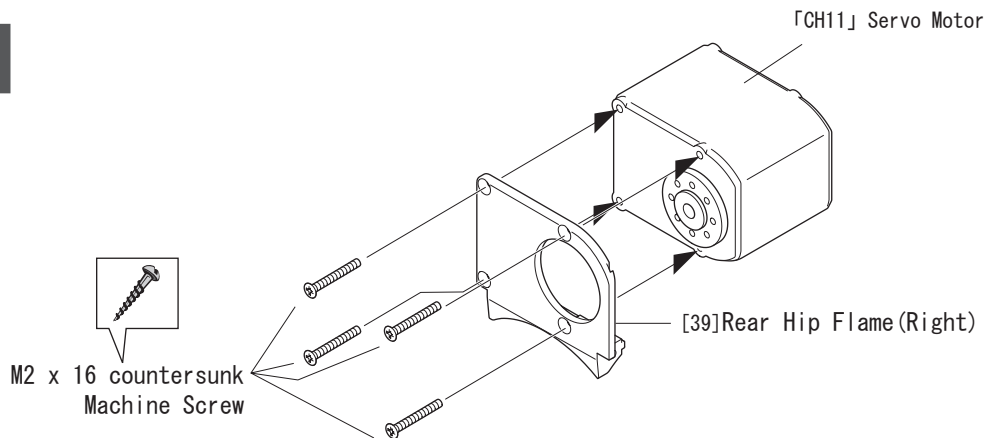

アイコン解説



注意



ポイント



締め込み注意

< @ 顎 方向注意

^ 組み立て順番



挟み込み注意

3

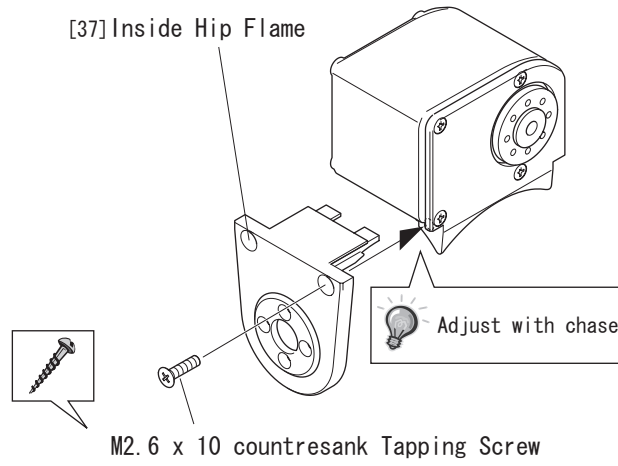

4

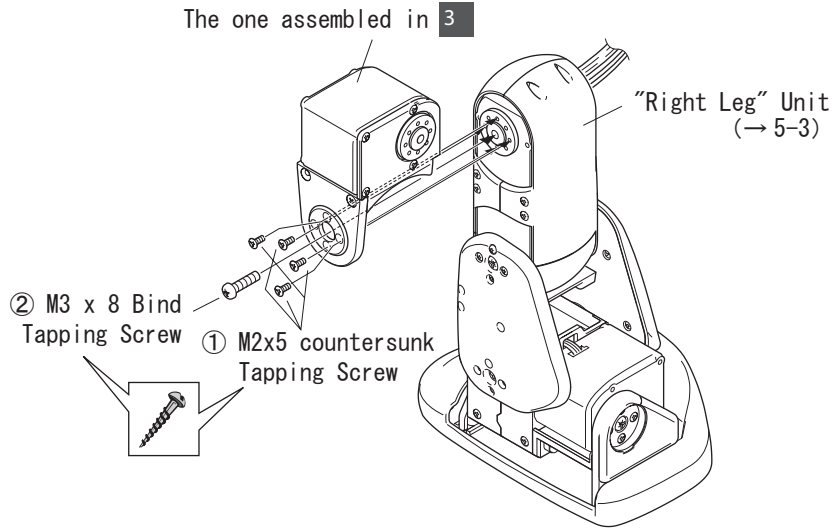

5

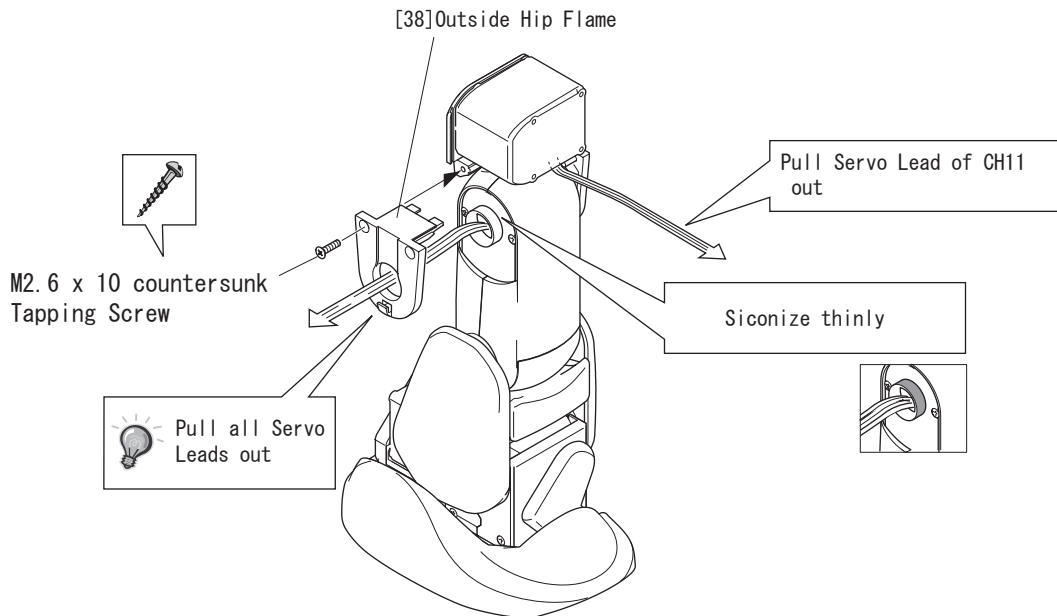

安全のための  
注意事項

付属製品に  
ついて

組み立て

ソフトウェア  
の設定

MANO  
遊び方  
での

オプションパー  
ツの取り付け

故障かなと  
思ったら

ユーザー相談  
室のご案内

用語集

パーツ販売  
リスト

展開図

アイコン解説



注意



ポイント



締め込み注意

<{@喜方向注意

^組み立て順番



挟み込み注意

6

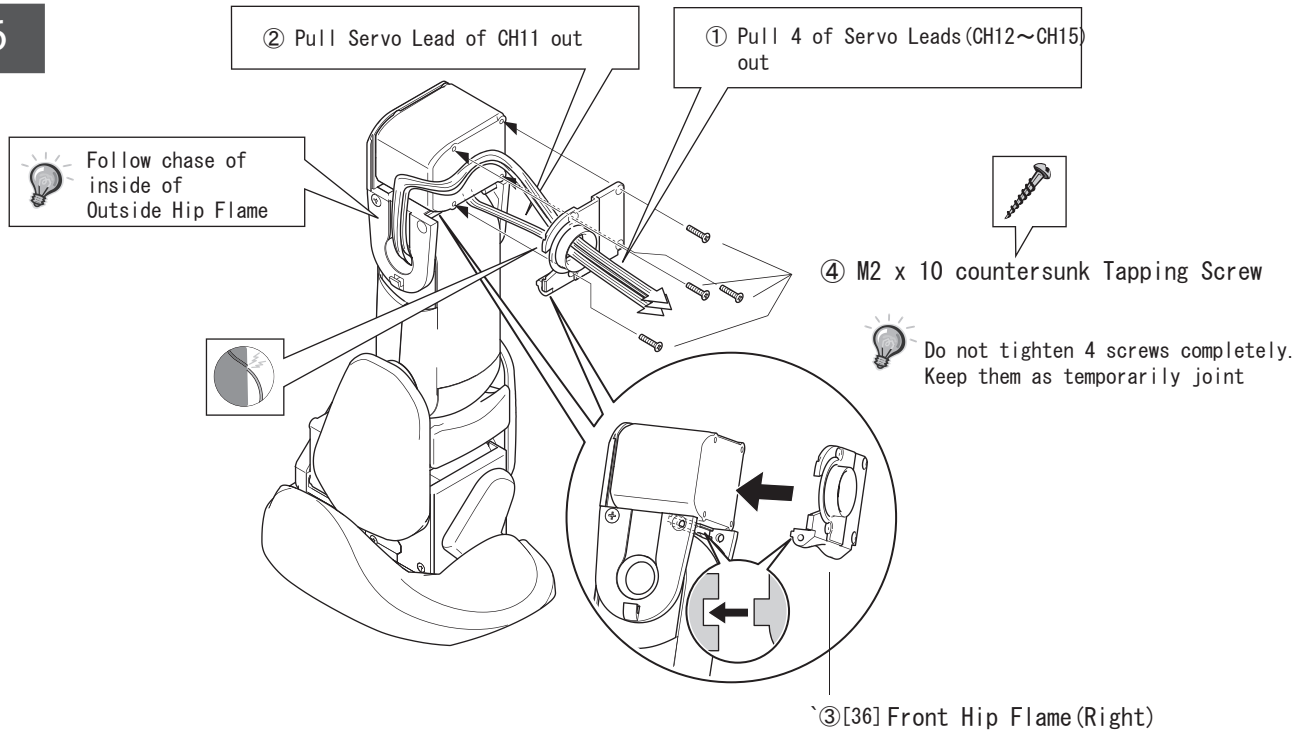

7

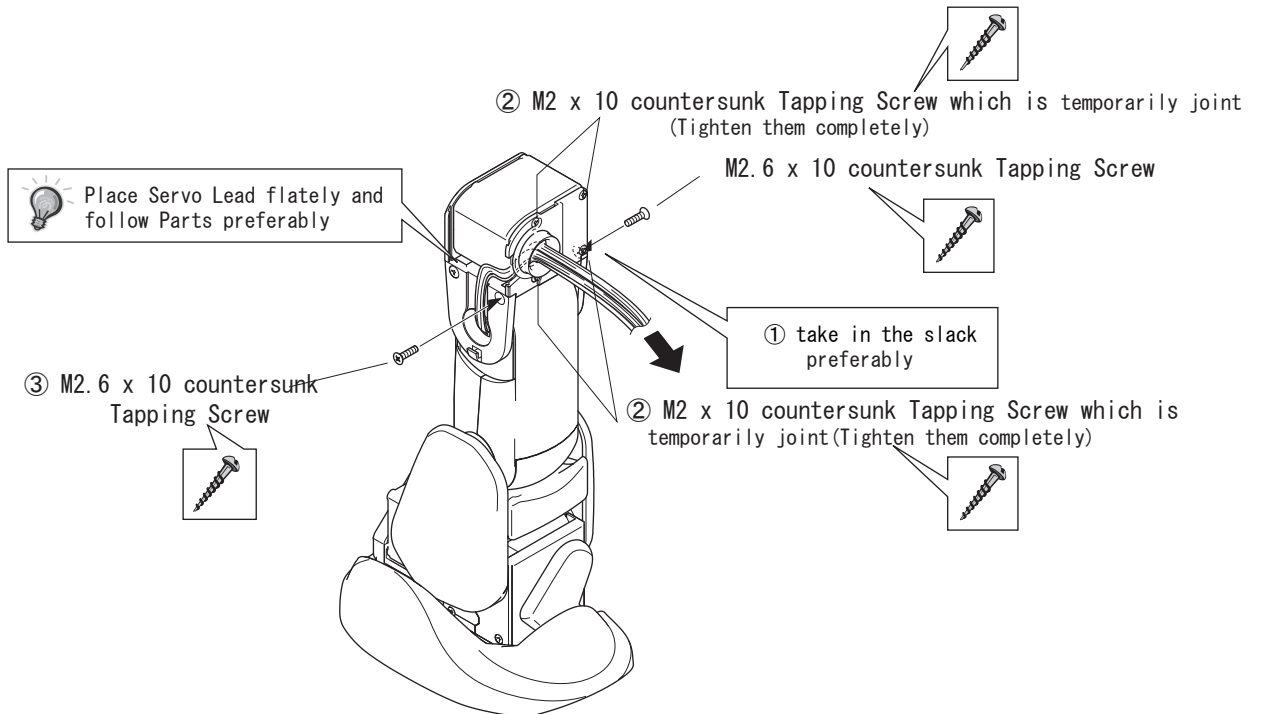

アイコン解説



注意



ポイント



締め込み注意

< { @ ■ 方向注意

^ 組み立て順番



挟み込み注意

## 5-5 Attaching of Covers(Right Leg)

Parts/Units from previous operation/step

「Righr Leg」 + 「Right Hip」 Unit (→ 5-4)

New Parts for this step

[40] Side Hip Cover x 1

[41] Ankle Cap x 1

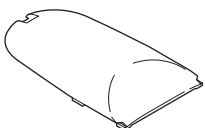

Side Hip Cover



Ankle Cap

1

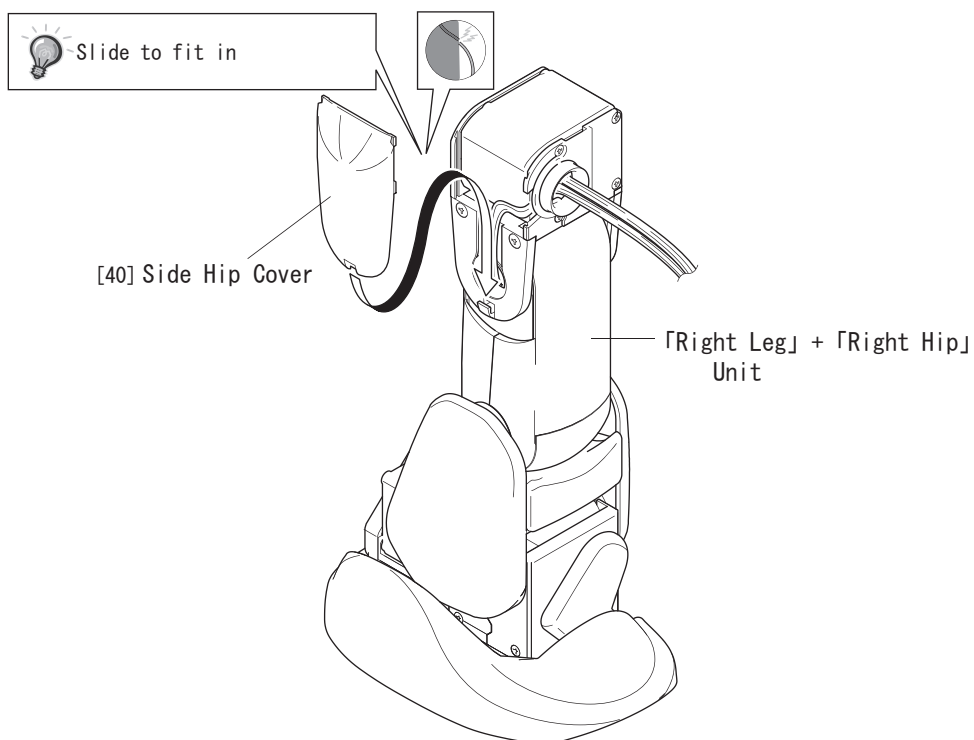

2

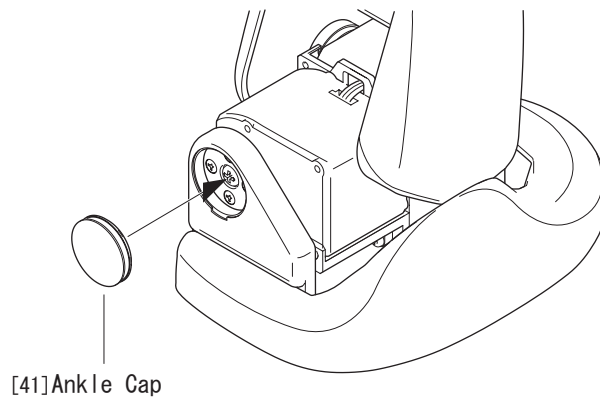

アイコン解説



注意



ポイント



締め込み注意



← {R} 方向注意

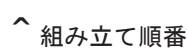

組み立て順番



挟み込み注意

## 5-6 Operation 5 Final Drawing

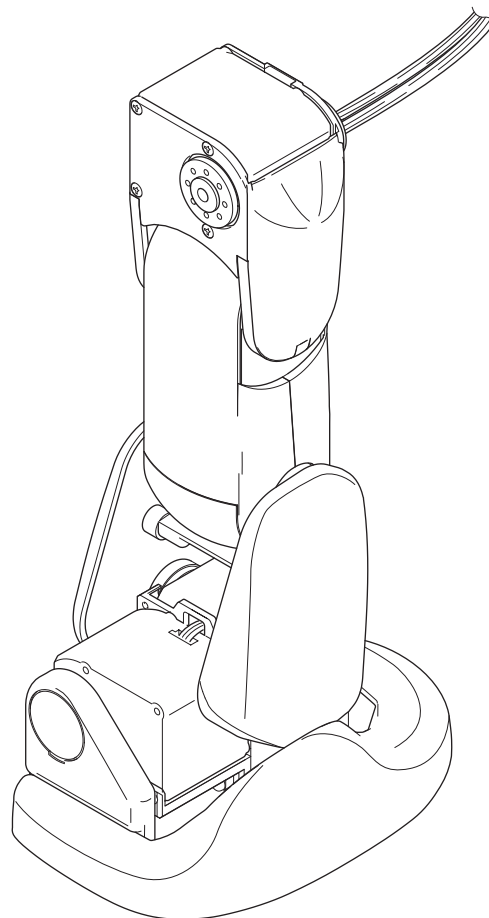
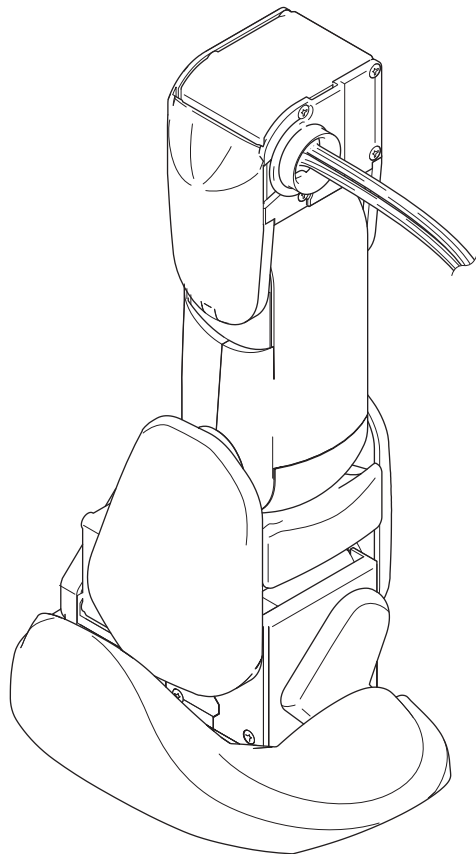

### アイコン解説



注意



ポイント



締め込み注意



< { @喜方向注意



組み立て順番



挟み込み注意

# 工程 06 Assembling Left Leg (Pack 6)

## 6-1 Assembling Left Ankle

Parts/Units from previous operation/step

「CH20」 Servo Motor (→ 2-4)

「CH21」 Servo Motor (→ 2-4)

New Parts for this step

[73] Low Height Servo Horn x 1

[21] Middle Ankle x 1

[22] Side ANkle x 1

[42] Front Ankle(Left) x 1

[24] Rear Ankle x 1

[43] Rear Ankle Joint(Left) x 1

[44] Front Ankle Joint(Left) x 1

[45] Shoe(Left) x 1

[46] Sole (Left) x 1

N2 x 5 countersunk Tapping Screw x 10

M2 x 10 countersunk Tapping Screw x 4

M2 x 16 countersunk Machine Screw x 10

M2.6 x 8 pan-head Tapping Screw x 2

M2.6 x 10 countersunk Tapping Screw x 4

M3 x 8 Bind Tapping Screw x 1



Low Height Servo Horn

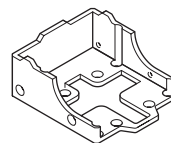

Middle Ankle

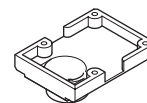

Side Ankle

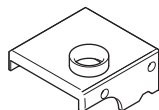

Front Ankle (Left)

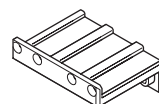

Rear Ankle

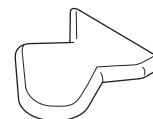

Front Ankle Joint (Left)

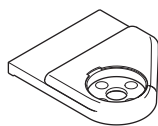

Rear Ankle Joint (Right)

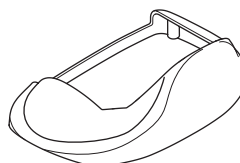

Shoe (Right)

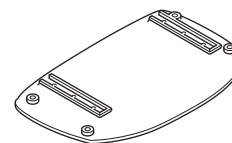

Sole (Right)

アイコン解説



注意



ポイント



締め込み注意



← { @ 顎 方向注意

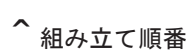

組み立て順番



挟み込み注意

安全のための  
注意事項

付属製品に  
ついて

組み立て

ソフトウェア  
の設定

MANUAL  
遊び方

での

オプションパー  
ツの取り付け

故障かなと  
思ったら

ユーザー相談  
室のご案内

用語集

パーツ販売  
リスト

展開図

1

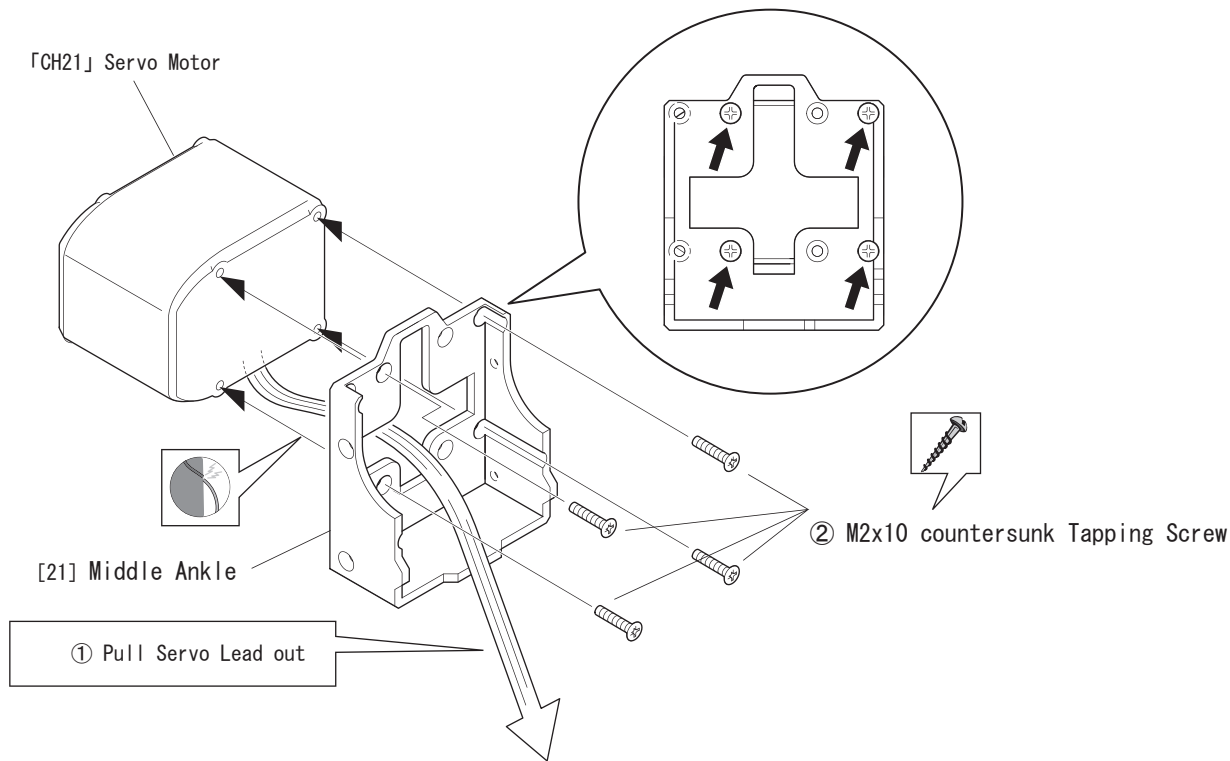

2

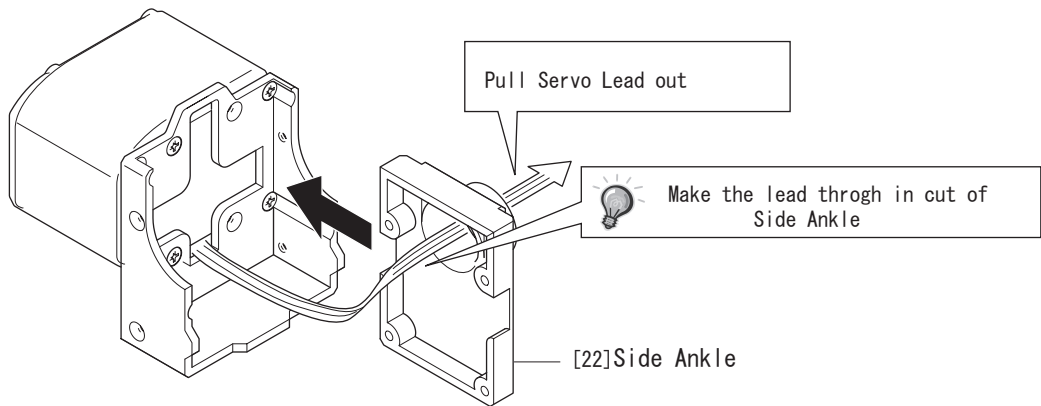

アイコン解説



注意



ポイント



締め込み注意

< { @ 幹方向注意

^ 組み立て順番



挟み込み注意



3

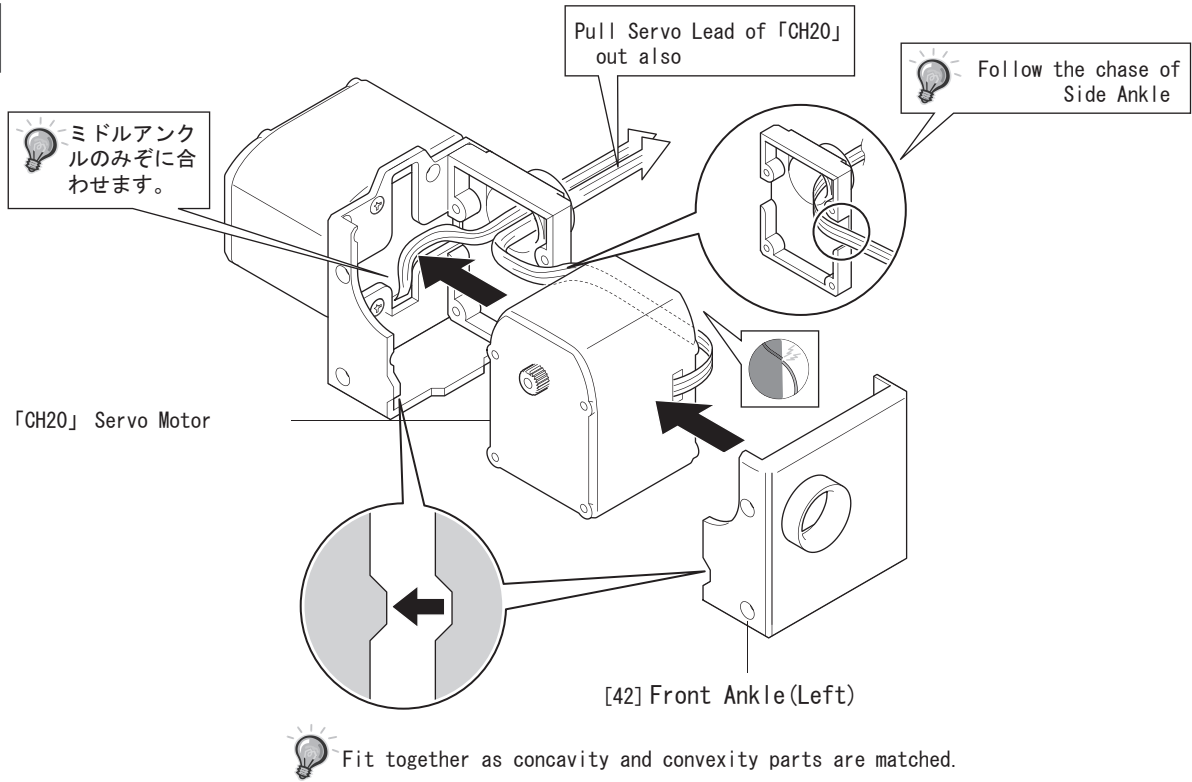

4

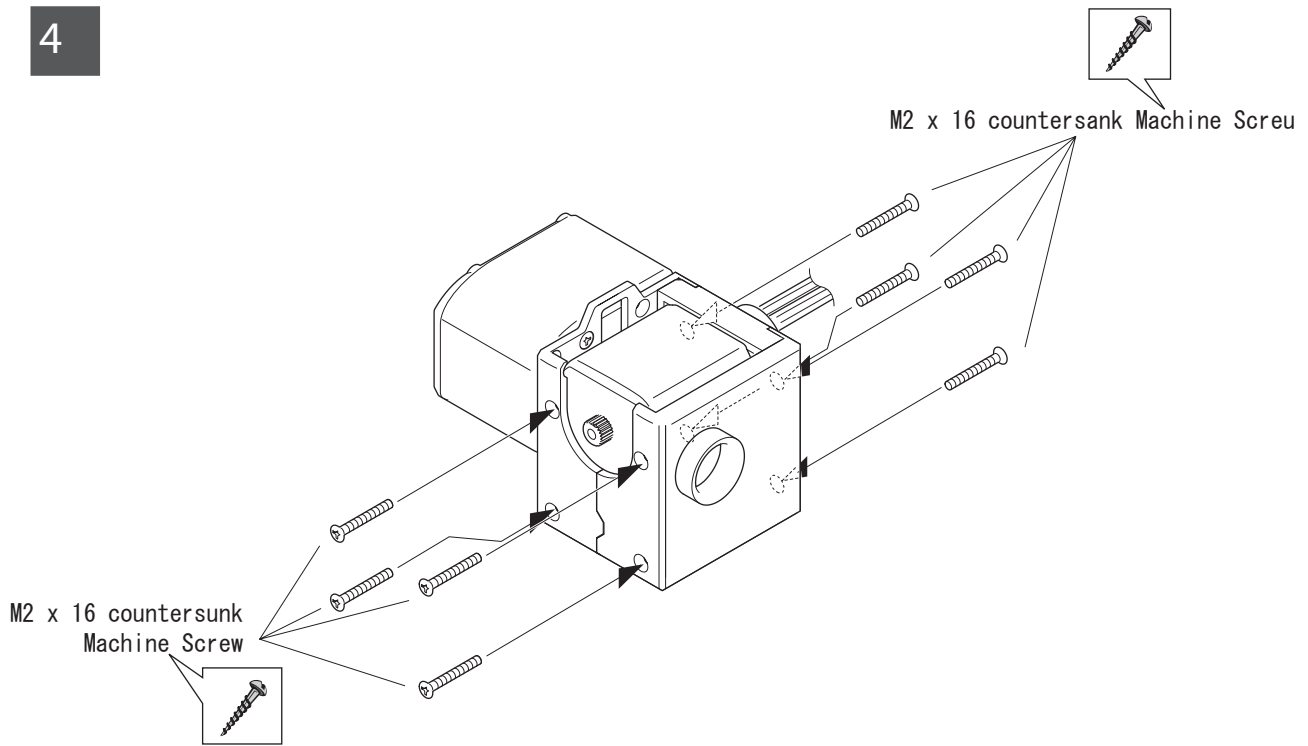

アイコン解説



注意



ポイント



締め込み注意



方向注意

組み立て順番



挟み込み注意

5

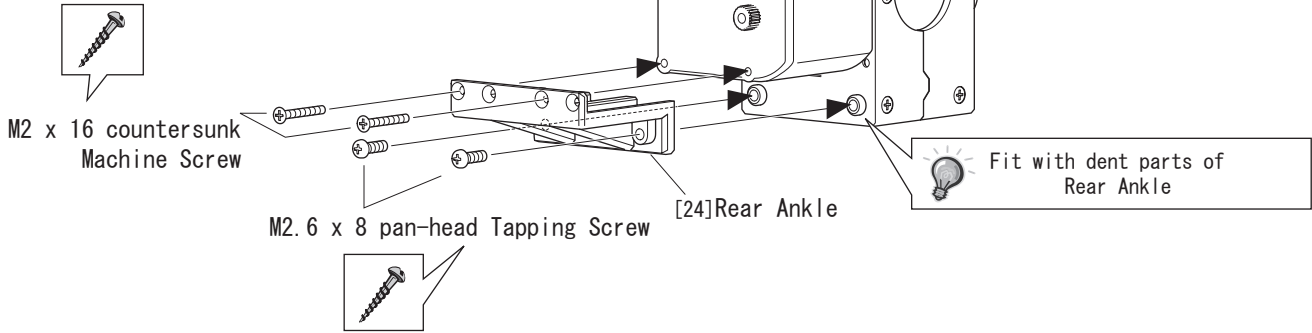

6

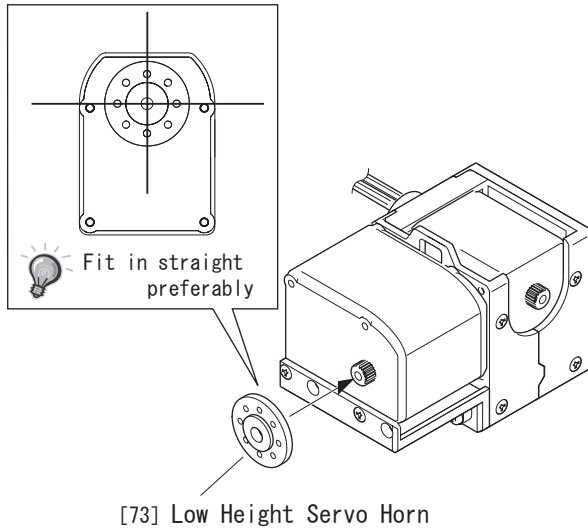

7

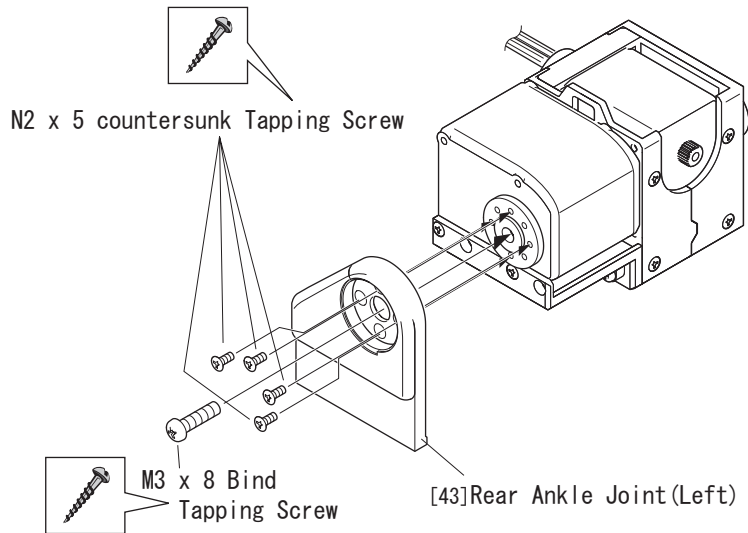

アイコン解説



注意



ポイント



締め込み注意

<{@喜方向注意

^ 組み立て順番



挟み込み注意

8

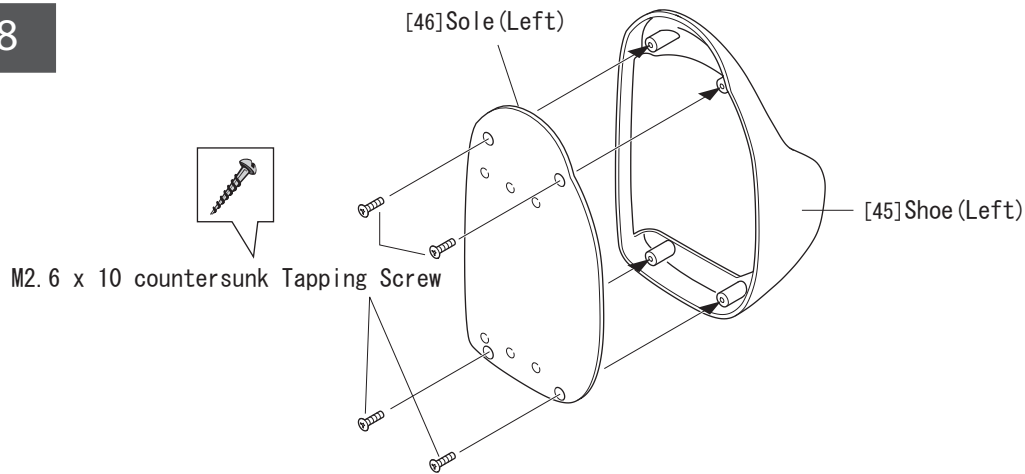

9

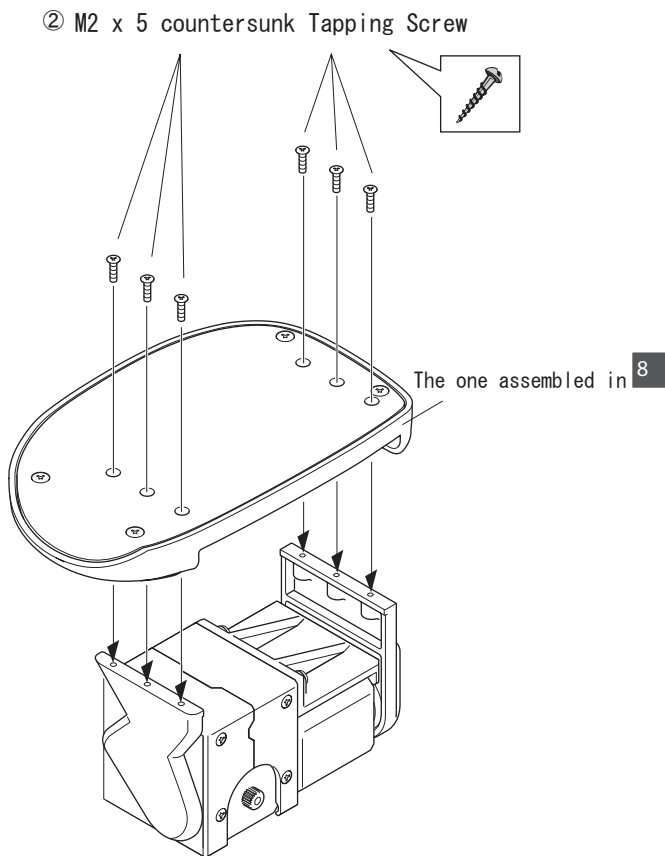
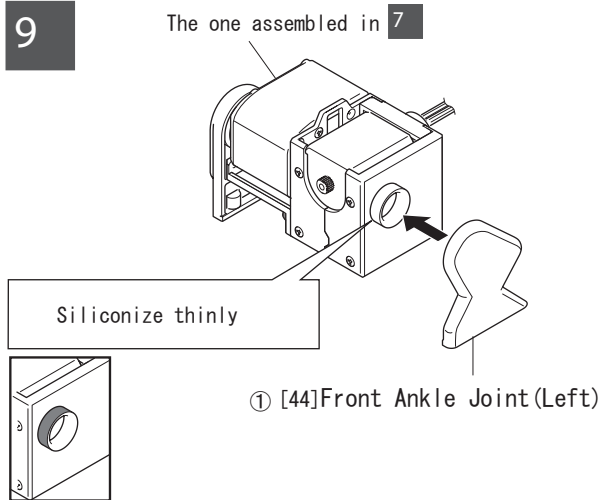

アイコン解説



注意



ポイント



締め込み注意

<{@喜方向注意

^組み立て順番



挟み込み注意

安全のための  
注意事項

付属製品に  
ついて

組み立て

ソフトウェア  
の設定

MANO  
遊び方 での

オプションパ  
ーの取り付け

故障かなと  
思ったら

ユーザー相談  
室のご案内

用語集

パーツ販売  
リスト

展開図

## 6-2 Assembling of Outside of Left Leg

Parts/Units from previous operation/step

"Left Ankle" Unit (→6-1)

New Parts for this step

[29] Outside Knee(Right) x 1

[30] Knee Cover(Right) x 1

[31] Knee Stay x 1

[32] Thigh Flame x 1

M2 x 5 pan-head Tapping Screw x 4

M2 x 8 pan-head Tapping Screw x 3

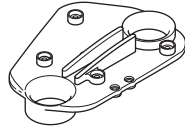

Outside Knee  
(Left)

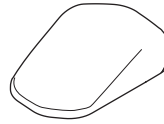

Knee Cover  
(Left)

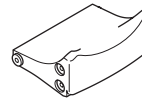

Knee Stay

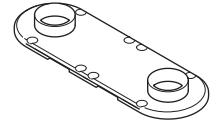

Thigh Flame

1

[31] Knee Stay

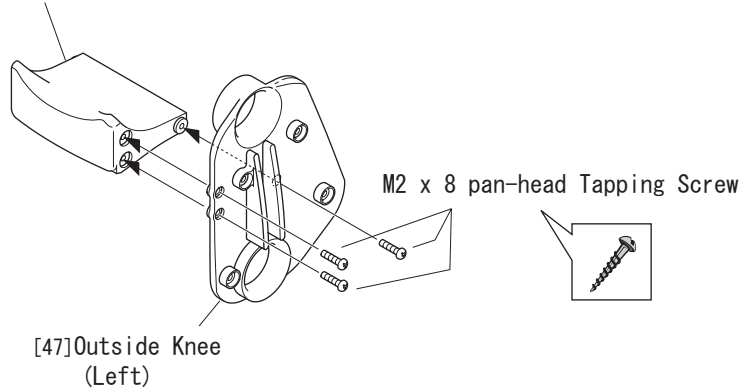

2

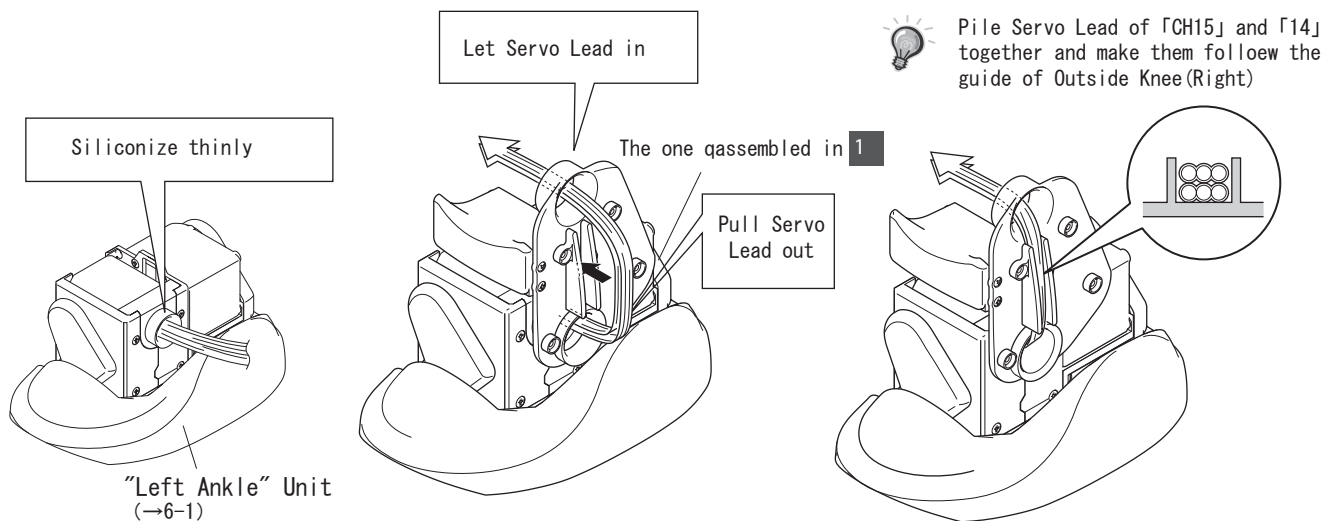

アイコン解説



注意



ポイント



締め込み注意

<{@ ■ 方向注意

^ 組み立て順番



挟み込み注意

3

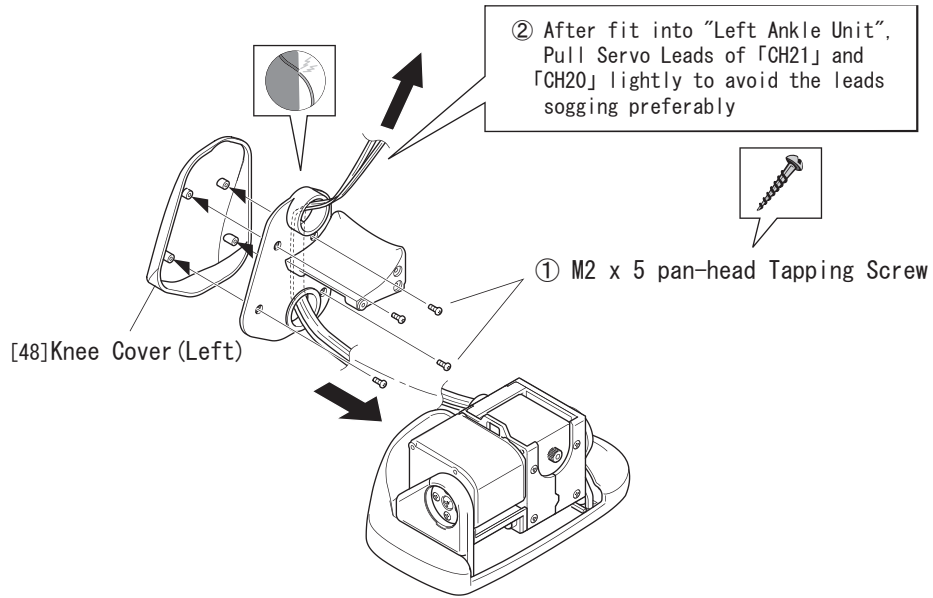

4

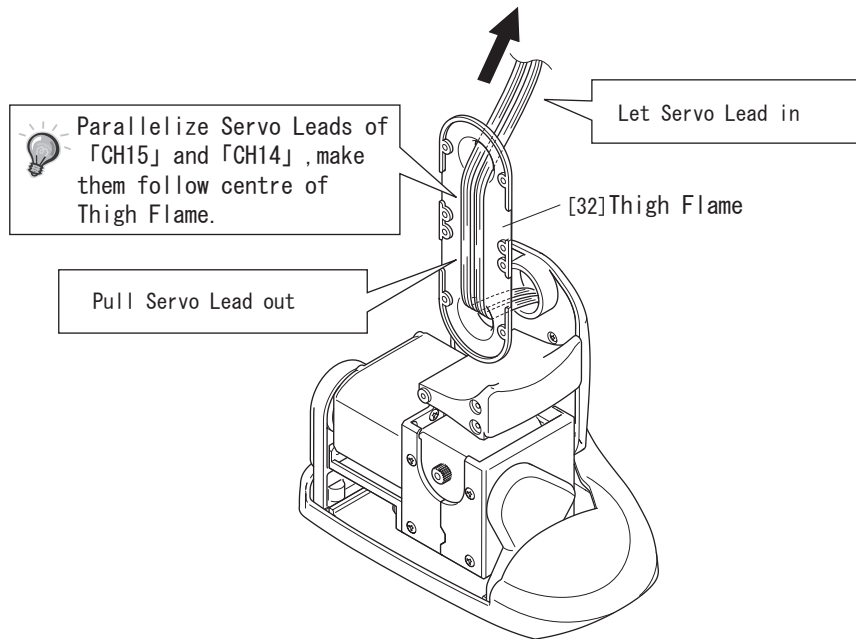

アイコン解説



注意



ポイント



締め込み注意



方向注意



組み立て順番



挟み込み注意

## 6-3 Assembling of Inside of Left Leg

Parts/Units from previous operation/step

"Left Ankle"+"Outside of RLeft Leg" Unit (→6-2)  
「CH18」 Servo Motor (→ 2-4)

「CH19」 Servo Motor (→ 2-4)

New Parts for this step

[73] Low Height Servo Horn x 3

[49] Inside Knee(Left) x 1

[50] Front Thigh Cover(Left) x 1

[51] Rear Thigh Cover(Left) x 1

M2 x 5 pan-head Tapping Screw x 8

M2 x 10 countersunk Tapping Screw x 8

M2 x 16 countersunk Machine Screw x 8

M3 x 8 Bind Tapping Screw x 2

M2 x 8 pan-head Tapping Sfcrow x 7



Low Height  
Servo Horn

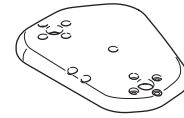

Inside Knee(Left)



Front Thigh  
Cover (Left)



Rear Thigh  
Cover (Left)

1

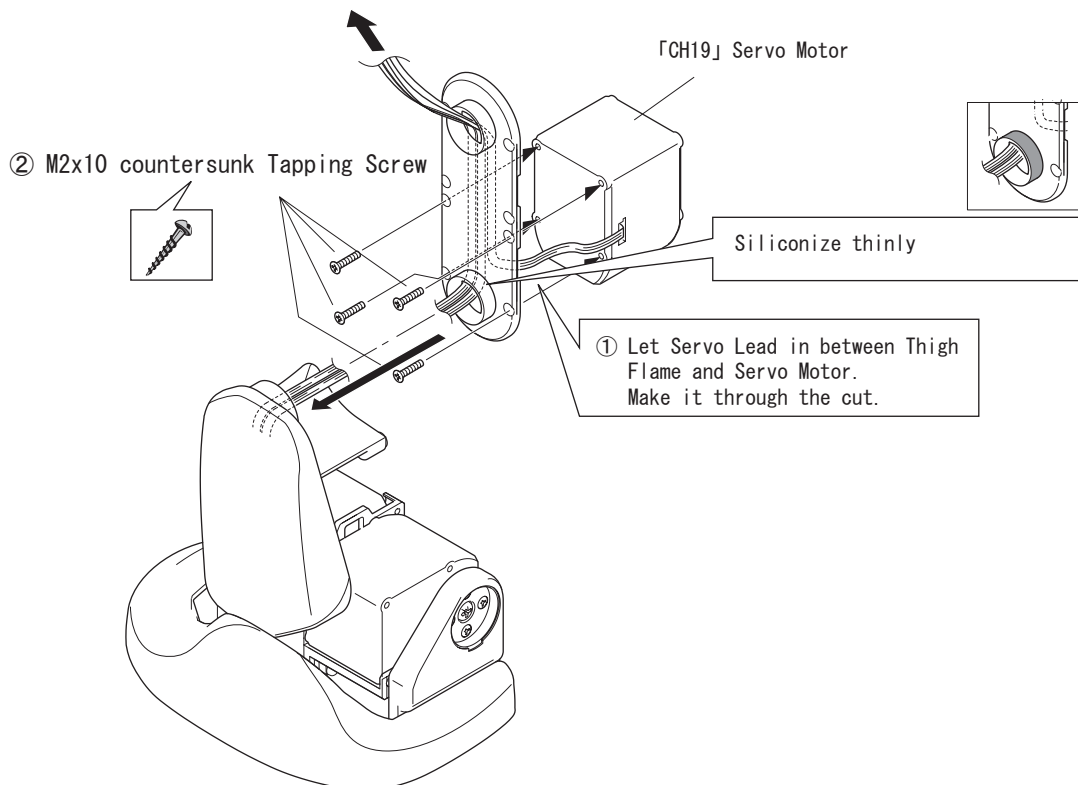

アイコン解説



注意



ポイント



締め込み注意

<[@喜方向注意

^ 組み立て順番



挟み込み注意

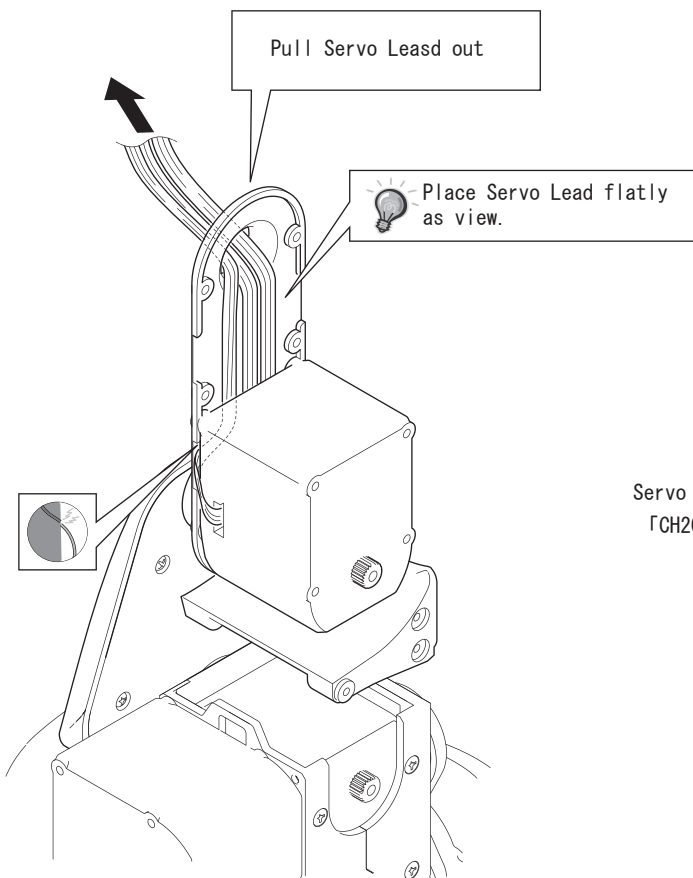

reference drawing of placement  
\*sight from upper side of the left view  
Thigh Flame

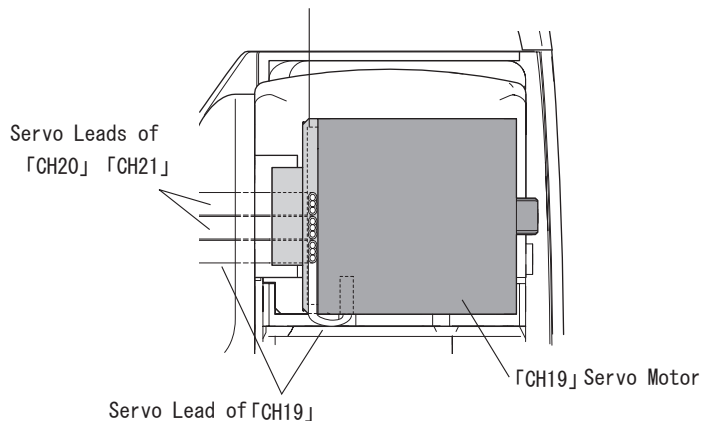

2

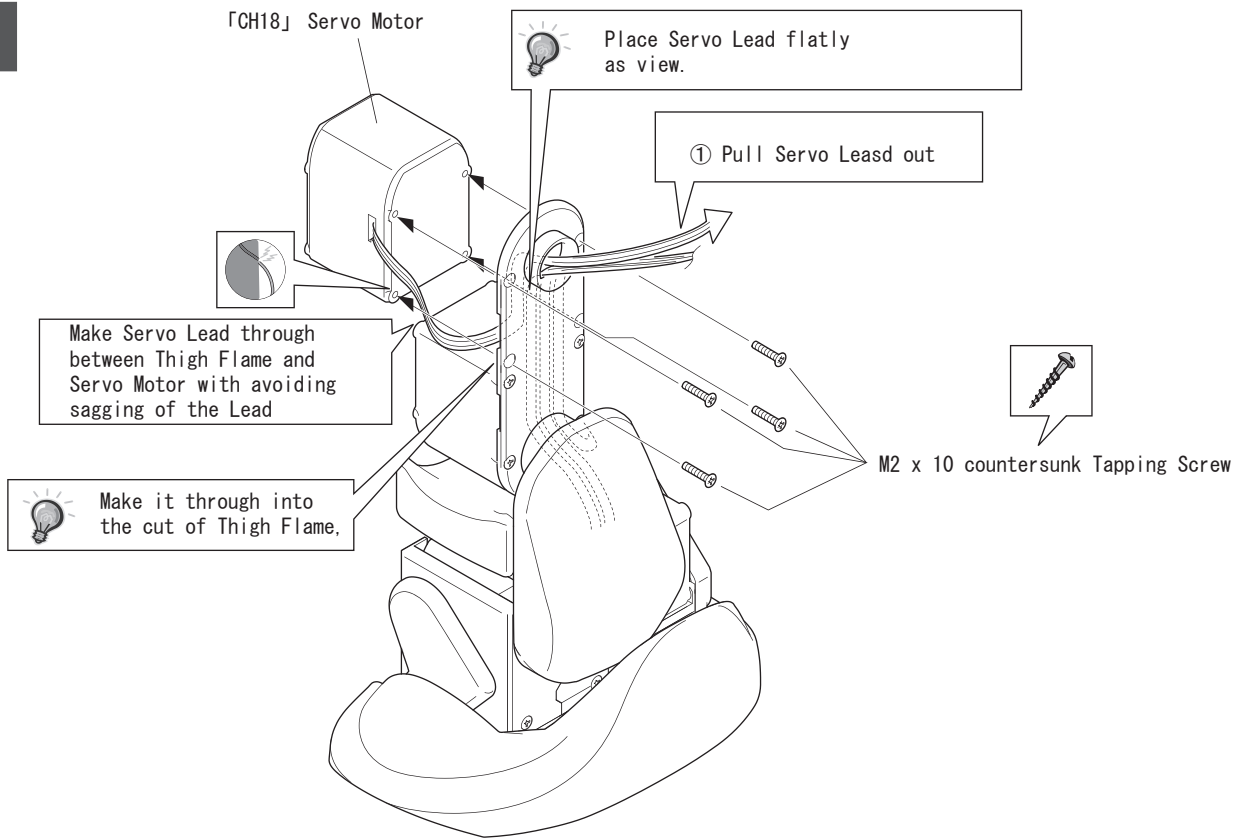

アイコン解説



注意



ポイント



締め込み注意



<

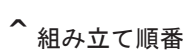

組み立て順番 挟み込み注意

3

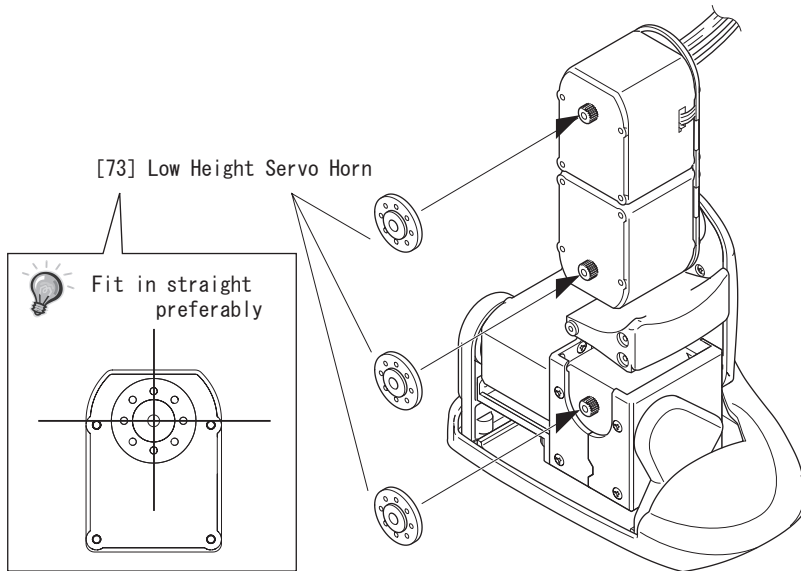

4

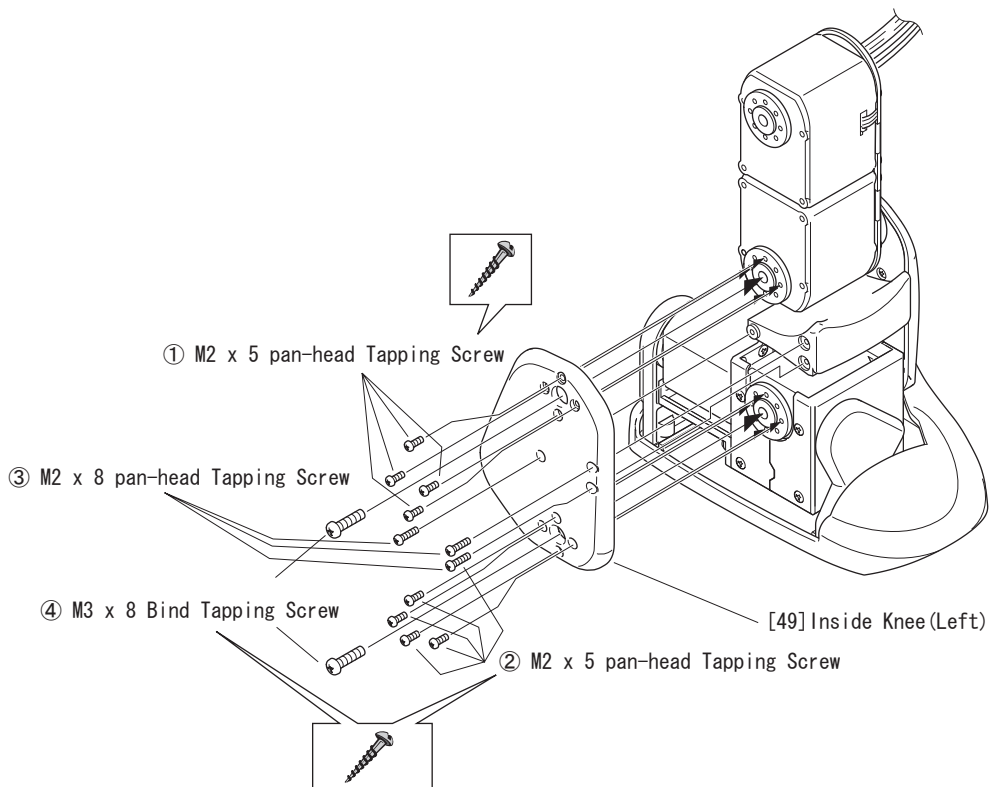

アイコン解説



注意



ポイント



締め込み注意

< { @ 喜 方向注意

^ 組み立て順番



挟み込み注意



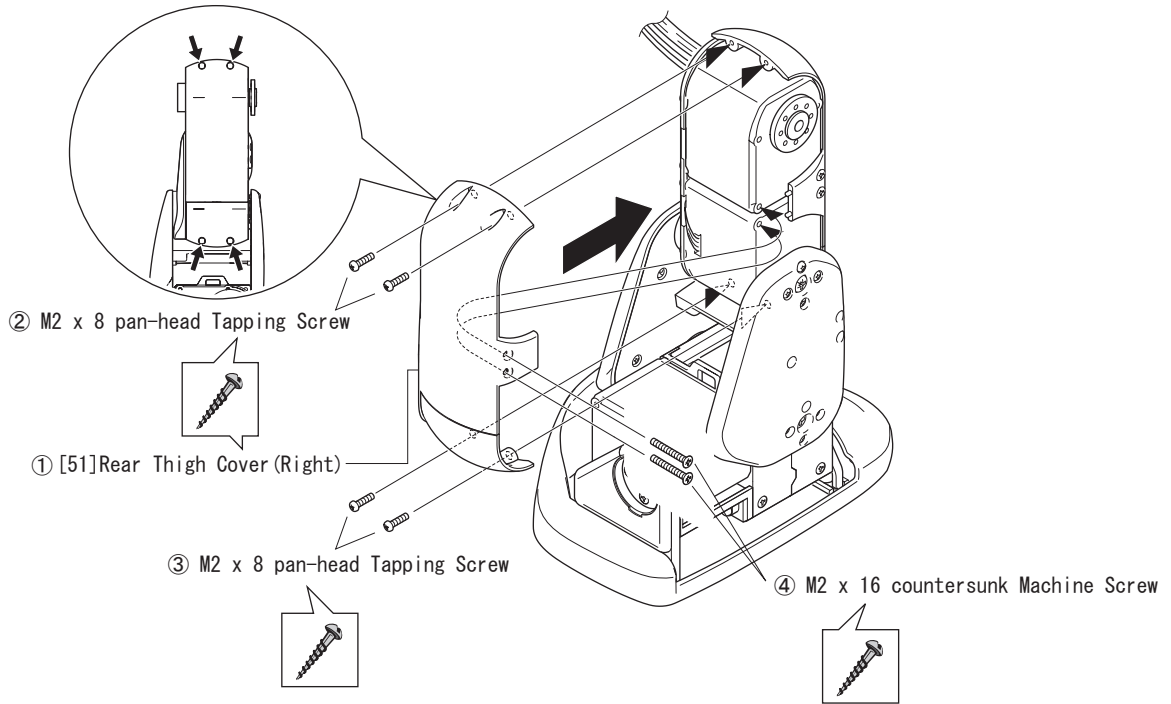
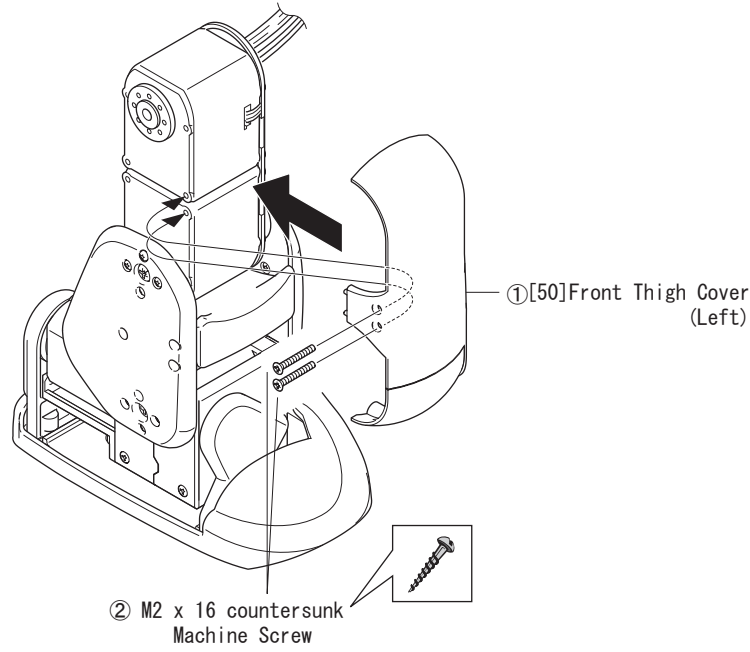

アイコン解説



注意



ポイント



締め込み注意



方向注意

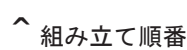

組み立て順番



挟み込み注意

## 6-4 Assembling of Left Hip

以前の工程から引き継ぐ部品 / ユニット

"Right Leg" Unit (→ 6-3)  
「CH17」 Servo Motor (→ 2-4)

新しく使用する部品

[73] Low Height Servo Horn x 1  
[52] Front Hip Flame(Left) x 1  
[37] Inside Hip Flame x 1  
[38] Outside Hip Flame x 1  
[53] Rear Hip Flame(Left)  
M2 x 5 countersunk Tapping Screw x 4  
M2 x 10 countersunk Tapping Screw x 4  
M2 x 16 countersunk Machine Screw x 4  
M2.6 x 10 countersunk Tapping Screw x 4  
M3 x 8 Bind Tapping Screw x 1

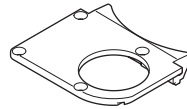

Rear Hip Flame (Right)

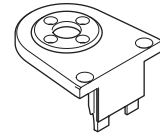

Inside Hip Flame

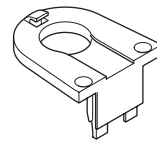

Outside Hip Flame

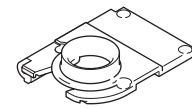

Front Hip Flame (Right)

1

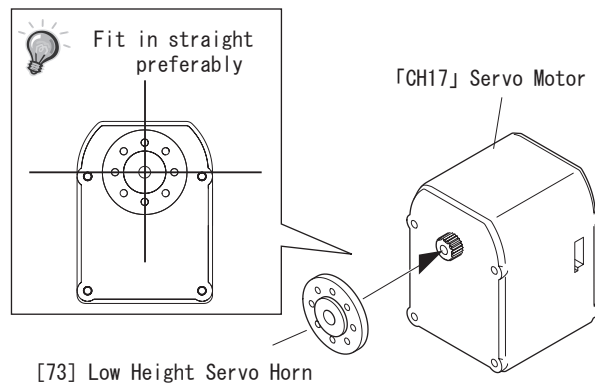

2

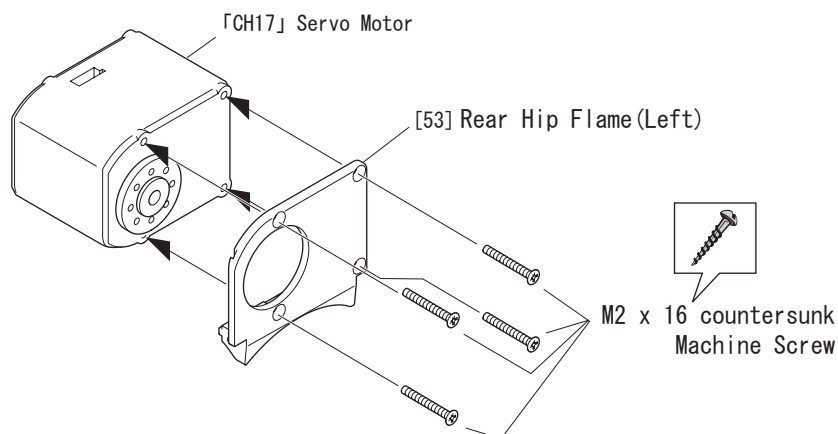

アイコン解説



注意



ポイント



締め込み注意

< @ 顎 方向注意

^ 組み立て順番



挟み込み注意

3

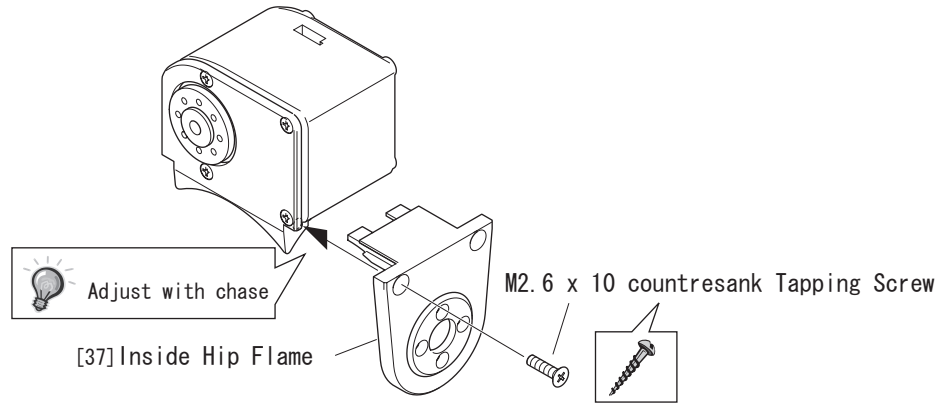

4

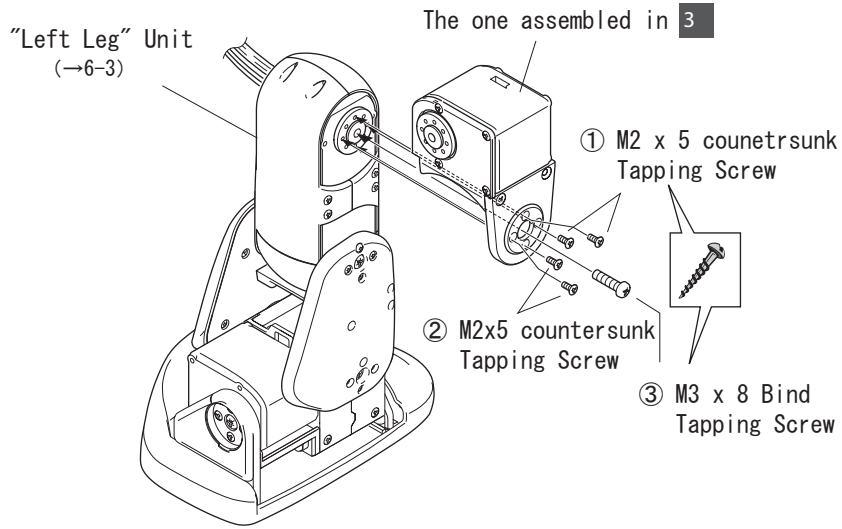

5

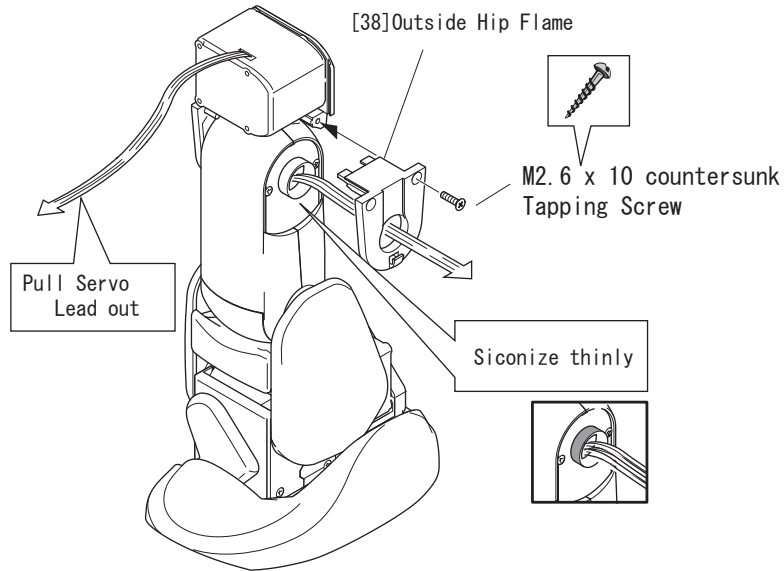

アイコン解説



注意



ポイント



締め込み注意

< @喜方向注意

^ 組み立て順番



挟み込み注意

安全のための  
注意事項

付属製品に  
ついて

組み立て

ソフトウェア  
の設定

MANO  
遊び方  
での

オプションパー  
ツの取り付け

故障かなと  
思ったら

ユーザー相談  
室のご案内

用語集

パーツ販売  
リスト

展開図

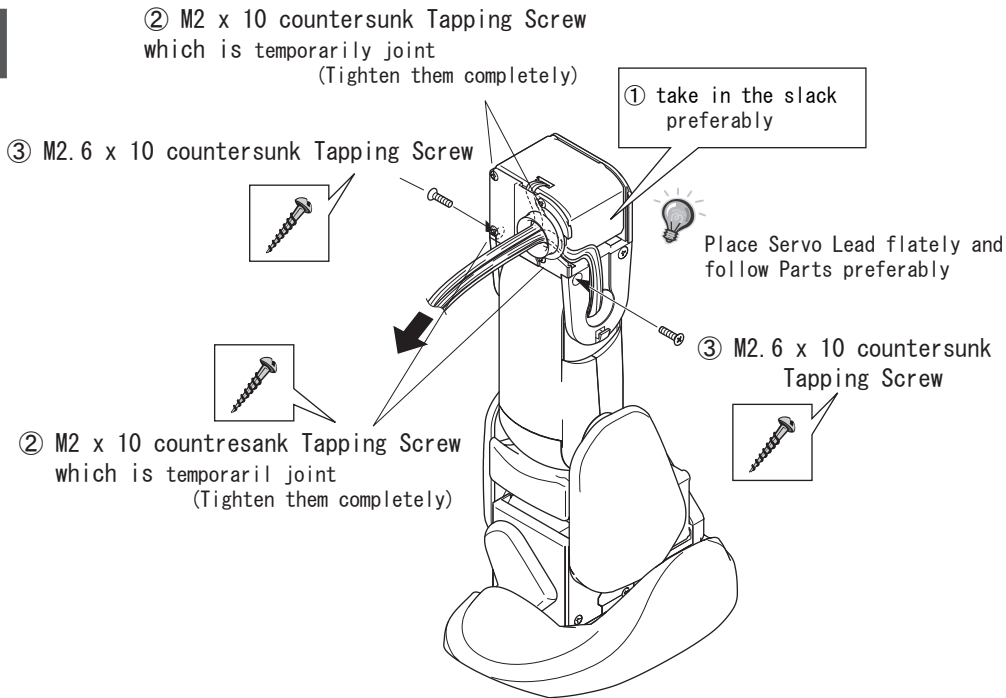
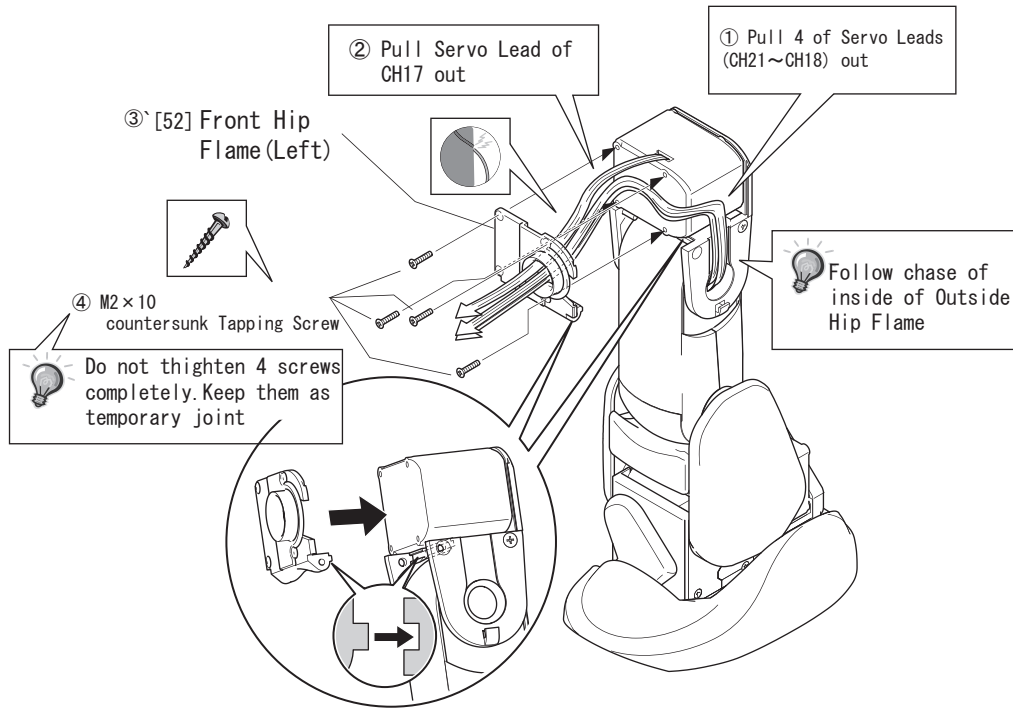

アイコン解説



注意



ポイント



締め込み注意

< { @ ■ 方向注意

^ 組み立て順番



挟み込み注意

## 6-5 Attaching of Covers(Left Leg)

Parts/Units from previous operation/step

「Left Leg」 + 「Left Hip」 Unit (→ 6-4)

New Parts for this step

[40] Side Hip Cover x 1

[41] Ankle Cap x 1

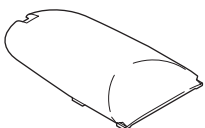

Side Hip Cover



Ankle Cap

1

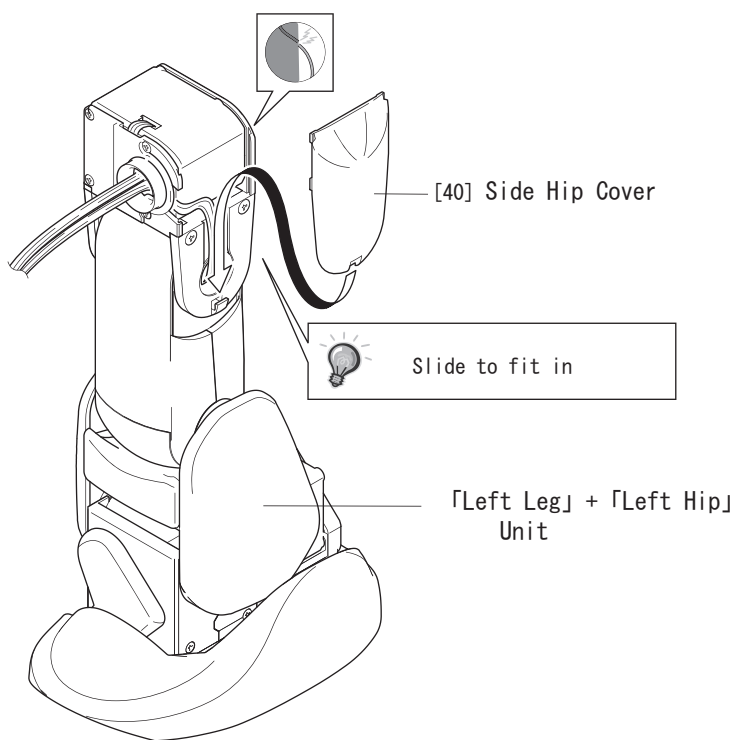

2

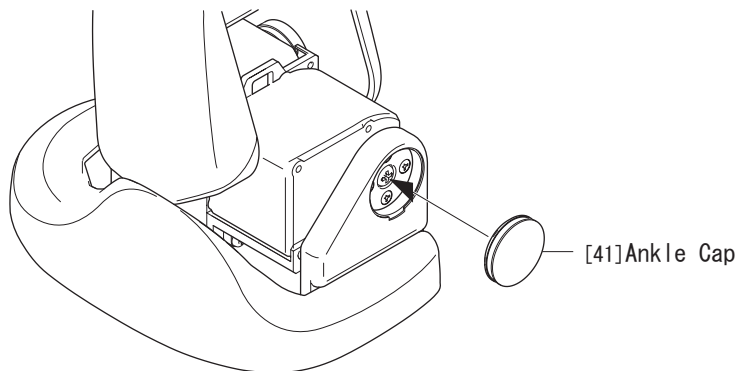

アイコン解説



注意



ポイント



締め込み注意

< { @ ■ 方向注意

^ 組み立て順番



挟み込み注意

## 6-6 Operation 6 Final Drawing

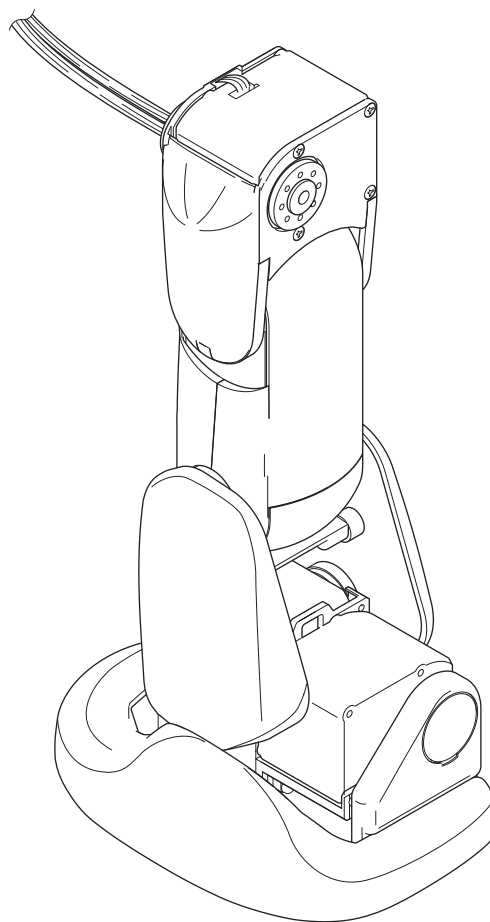
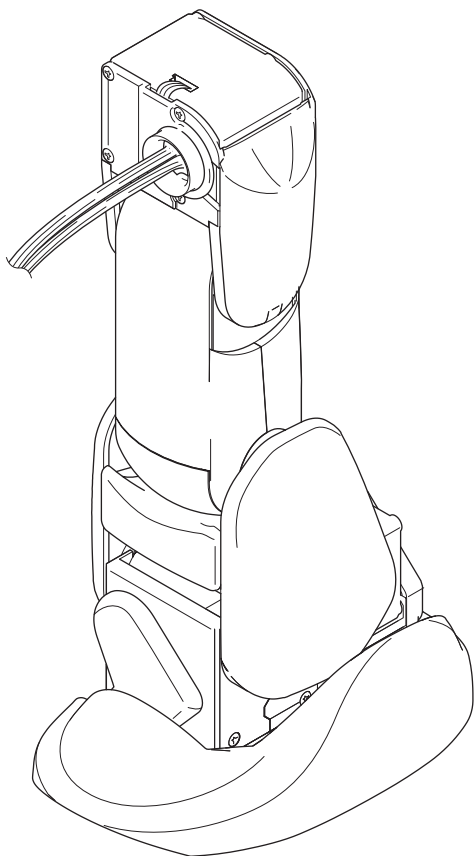

### アイコン解説



注意



ポイント



締め込み注意



<{@喜方向注意



組み立て順番



挟み込み注意

# 工程 07 Assembling Head Part (Pack 7)

## 7-1 Assembling Neck Part

Parts/Units from previous operation/step

「CH1」 Servo Motor (→ 2-4)

New Parts for this step

[73] Low Height Servo Horn x 1

[54] Neck Support x 1

[55] Neck Base x 1

[56] Head Base x 1

M2 x 10 countersunk Tapping Screw x 4

M2 x 20 countersunk Machine Screw x 2

M3 x 8 Bind Tapping Screw x 1

M2 x 8 countersunk x Tapping Screw x 4



Low Height Servo Horn



Neck Support

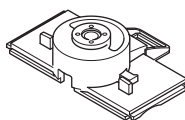

Neck Base

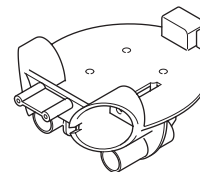

Head Base

1

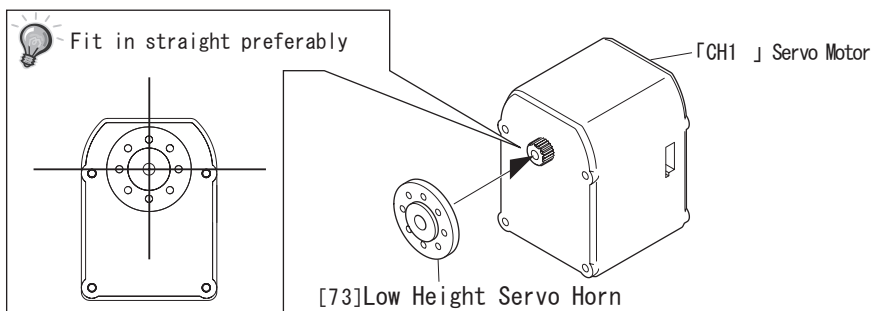

アイコン解説



注意



ポイント



締め込み注意

< @ 方向注意

^ 組み立て順番



挟み込み注意

安全のための  
注意事項

付属製品に  
ついて

組み立て

ソフトウェア  
の設定

MANUAL  
での  
遊び方

オプションパー  
ツの取り付け

故障かなと  
思ったら

ユーザー相談  
室のご案内

用語集

パーツ販売  
リスト

展開図

2

 Hold Servo Lead part and pull out straight

① Pull Servo Lead out from 「CH01」 Servo Motor at this step.

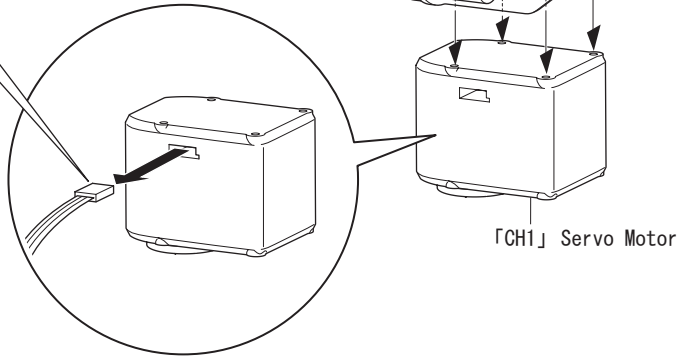

③ Insert The connector which was pulled out in ① into Servo Motor.

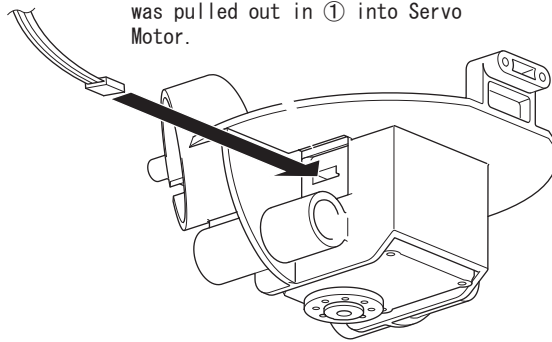

3

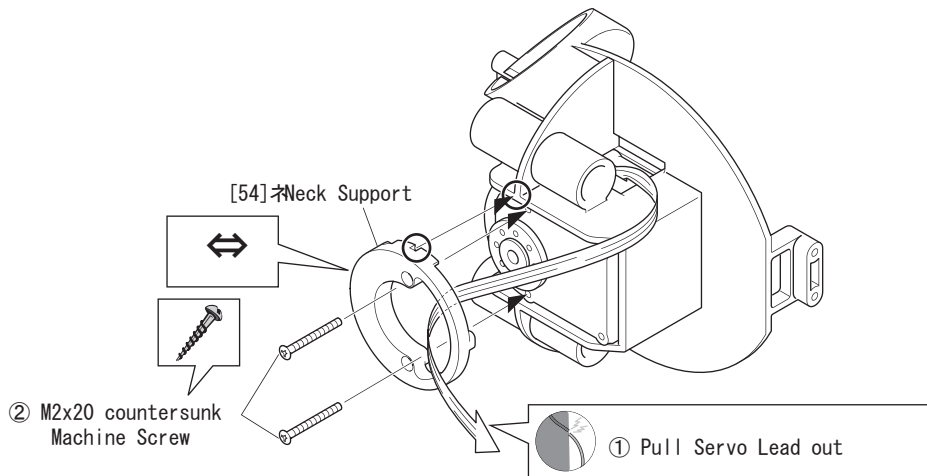

アイコン解説



注意



ポイント



締め込み注意

< { @ 喜 方向注意

^ 組み立て順番



挟み込み注意



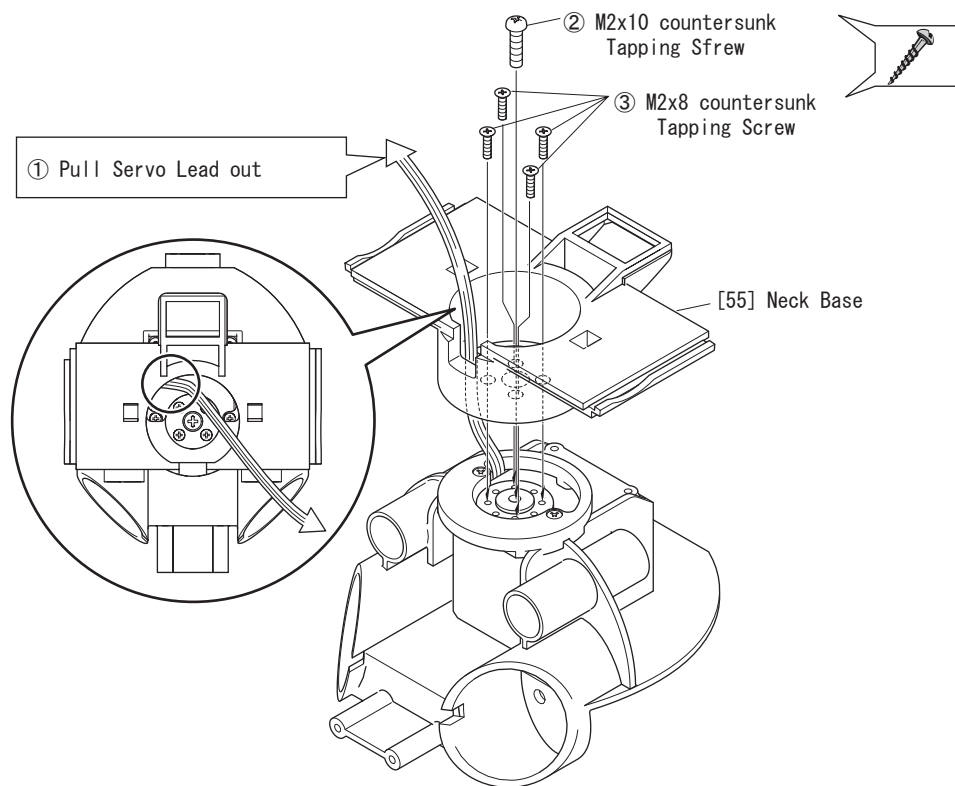

アイコン解説



注意



ポイント



締め込み注意



<{@核方向注意



組み立て順番



挟み込み注意

## 7-2 Assembling Head and Face

Parts/Units from previous operation/step

"Neck" Unit (→7-1)

New Parts for this step

[57] Eye Base x 2

[58] Eye x 2

[59] Pupil x 2

[60] Face x 1

[61] Back Head x 1

M2.6 x 10 pan-head Tapping Screw x 6



Eye Base



Eye



Pupil

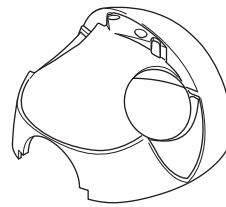

Face

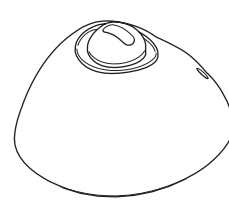

Back Head

1

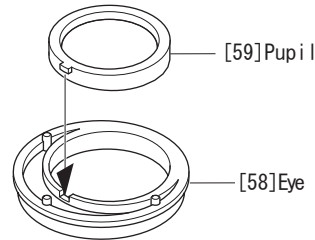
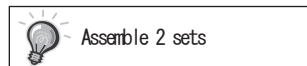

2

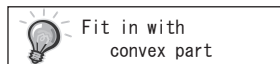
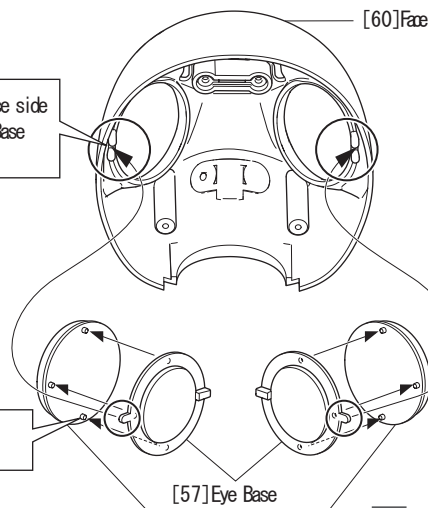
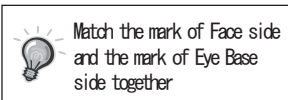

The One assembled in-1

アイコン解説



注意



ポイント



締め込み注意

<[@顎方向注意

^ 組み立て順番



挟み込み注意

3

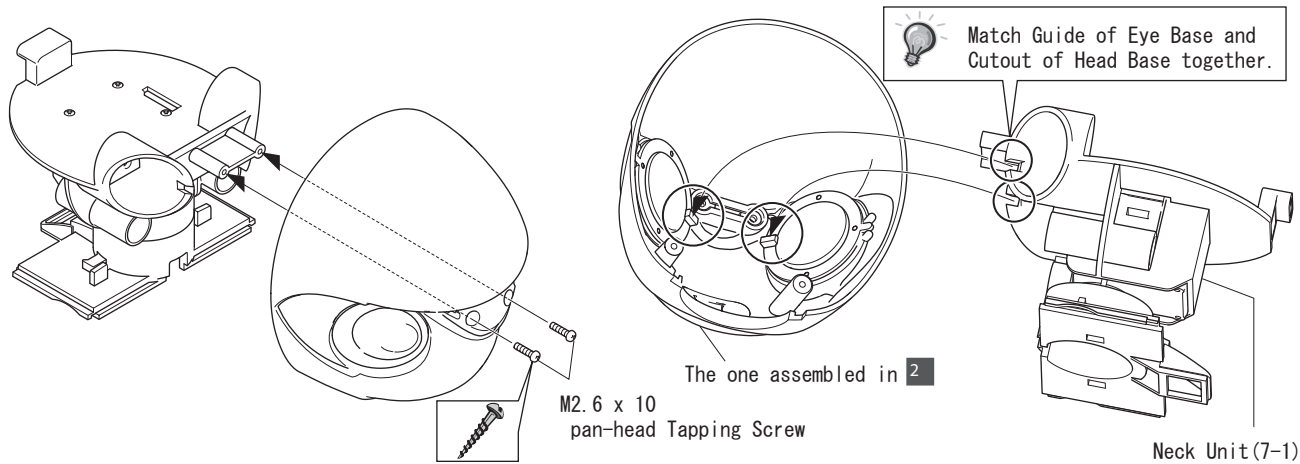

For Tapping Screw of 3 4, tighten all of them temporarily first, then tighten them completely, it will be easy to match gap of Face and Back Head.

4

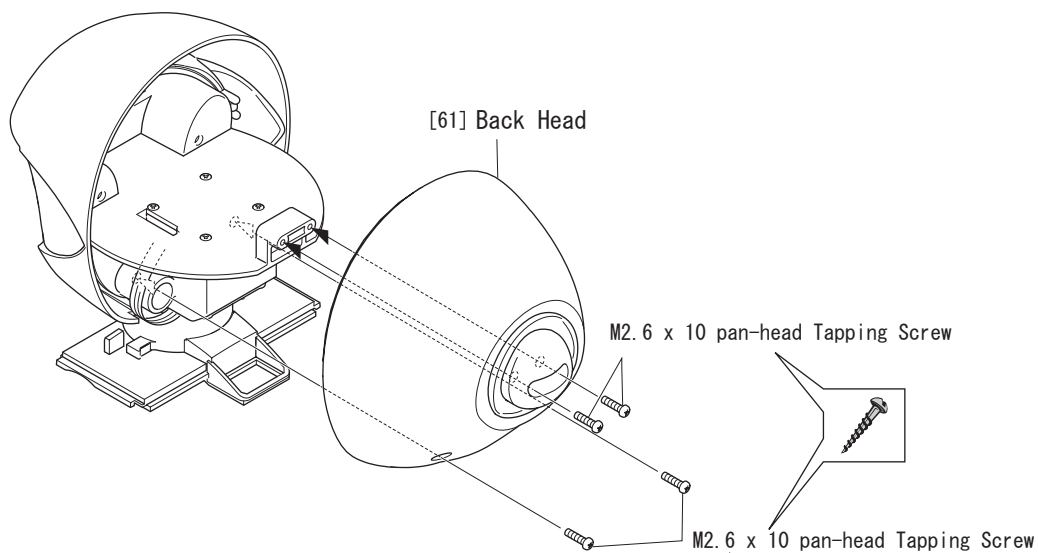

For these 2 screws, use Ratchet Screwdriver in recommendation [No. HRP012] or long screwdriver (#1) to tighten.

Case of set Radio Controlled Unit in  
Radio Control Unit can be mounted at head part of MANO1 PF01. If user has purchased Radio Controlled Unit in advance, it is recommended to see Operation OP01 [Operate by Radio Control] in P178 to set Radio Control Unit in during process of 3 4

アイコン解説



注意



ポイント



締め込み注意

< { @ ■ 方向注意

^ 組み立て順番



挟み込み注意

## 7-3 Attaching Covers (Head)

Parts/Units from previous operation/step

「Neck+Head」 Unit (→ 7-2)

New Parts for this step

[62] Visor x 1

[63] Back Head Cap x 1



Visor



Back Head Cap

1

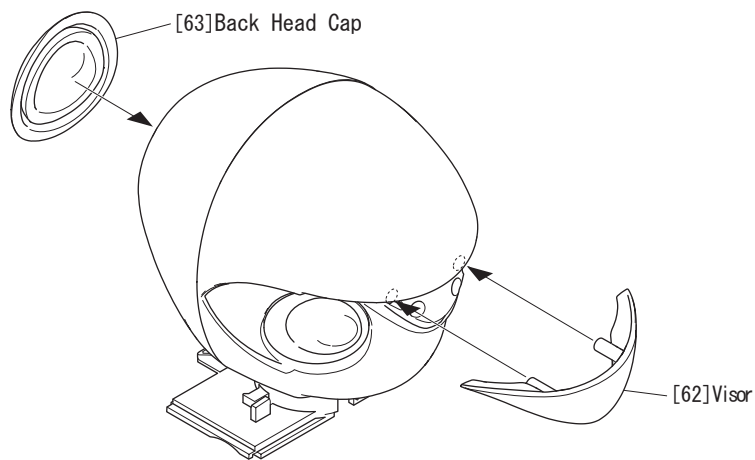

アイコン解説



注意



ポイント



締め込み注意



←[@喜方向注意



組み立て順番



挟み込み注意

# 7-4 Operation 7 Final Drawing

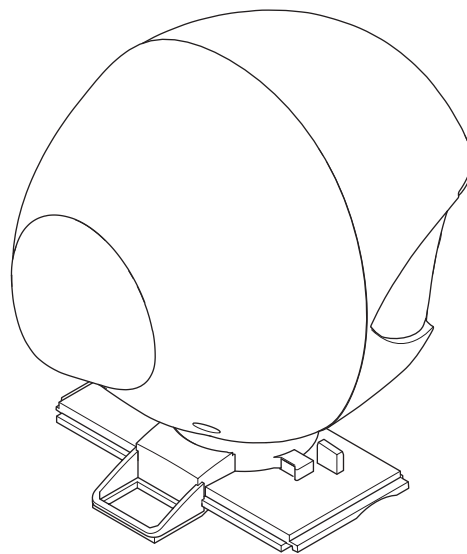
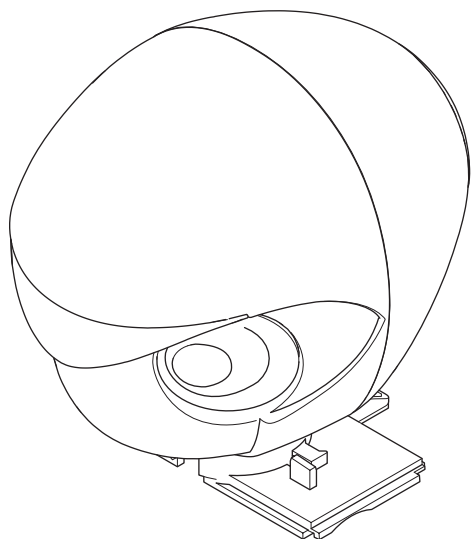

### アイコン解説



注意



ポイント



締め込み注意



方向注意



組み立て順番



挟み込み注意

## 8-1 Attaching Legs

Parts/Units from previous operation/step

Back Body Flame (→ 2-5)  
「Right」 Leg Unit (→ 5-6)

「Left Leg」 Unit (→ 6-6)

New Prats for this step

M2 x 5 countersunk Tapping Screw x 8  
M3 x 8 Bind Tapping Screw x 2

1

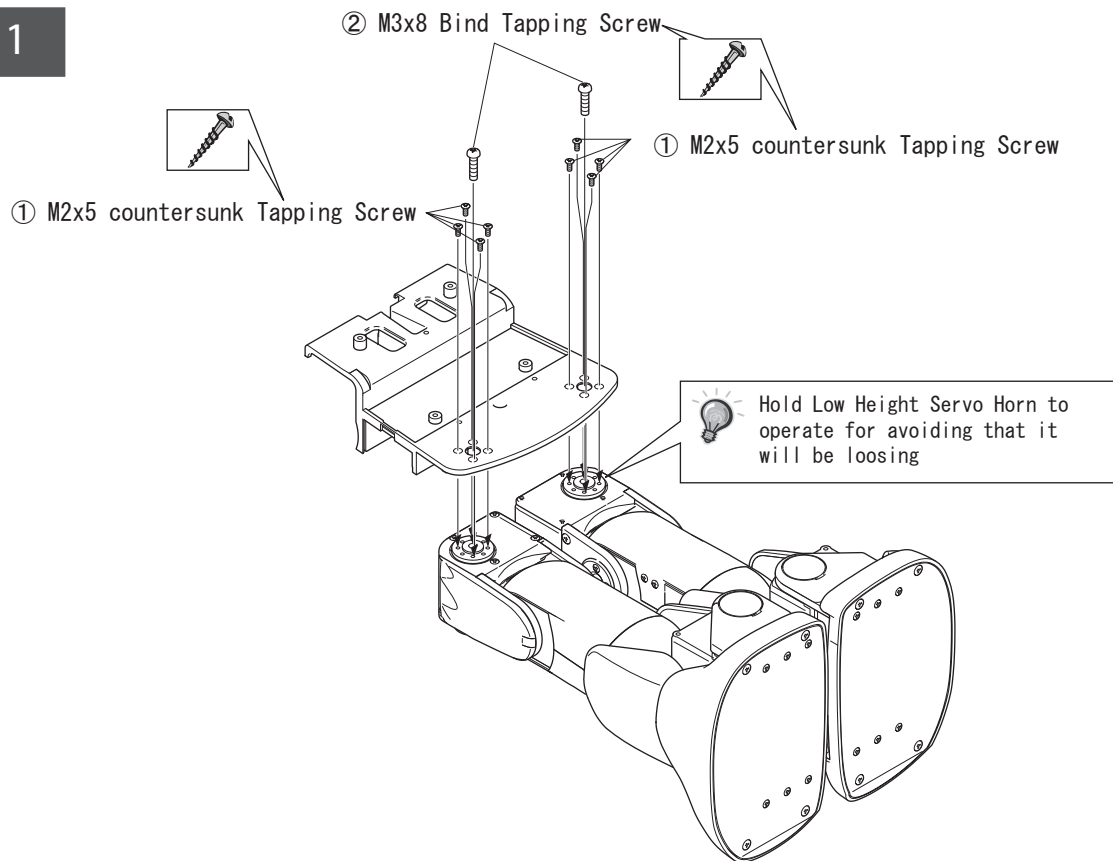

アイコン解説



注意



ポイント



締め込み注意

<{@顎方向注意



組み立て順番



挟み込み注意

## 8-2 Attaching Both Arms and Head

### Parts/Units from previous operation/step

Power Board Unit (→ 2-5)

Front Body Flame Unit (→ 2-5)

Control Board (→ 2-5)

Control Board Cover (→ 2-5)

[Right Arm] Unit (→ 3-7)

[Left Arm] Unit (→ 4-7)

[Head] Unit (→ 7-4)

[Body+Both Legs] Unit (→ 8-1)

[90] Switch (→ 2-5)

### New Parts for this step

M2.6 x 14 pan-head Tapping Screw x 4

1

\*Follow numbers for assembling order

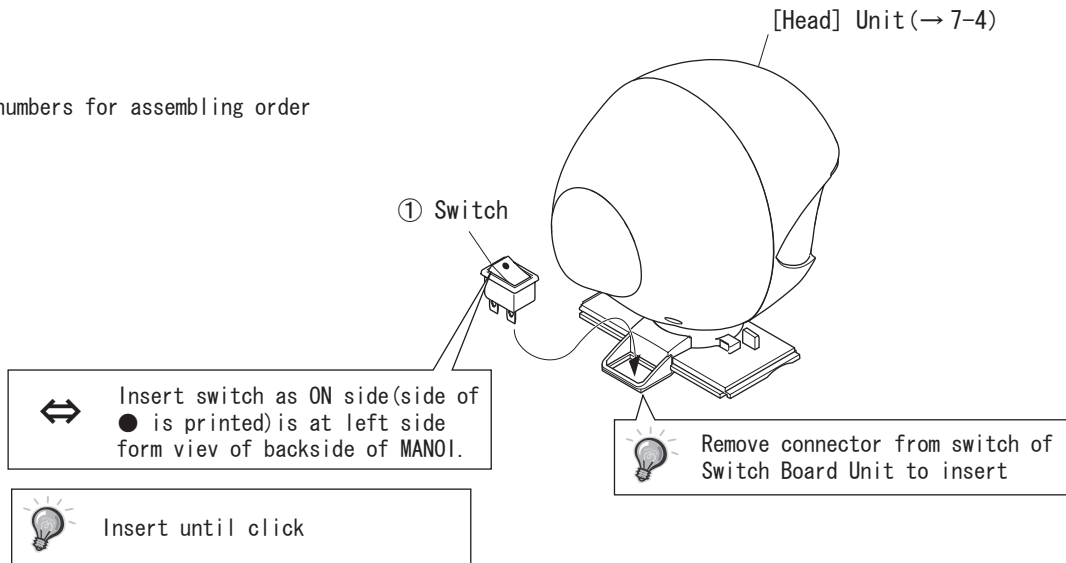

### アイコン解説



注意



ポイント



締め込み注意

< @ 方向注意

^ 組み立て順番



挟み込み注意

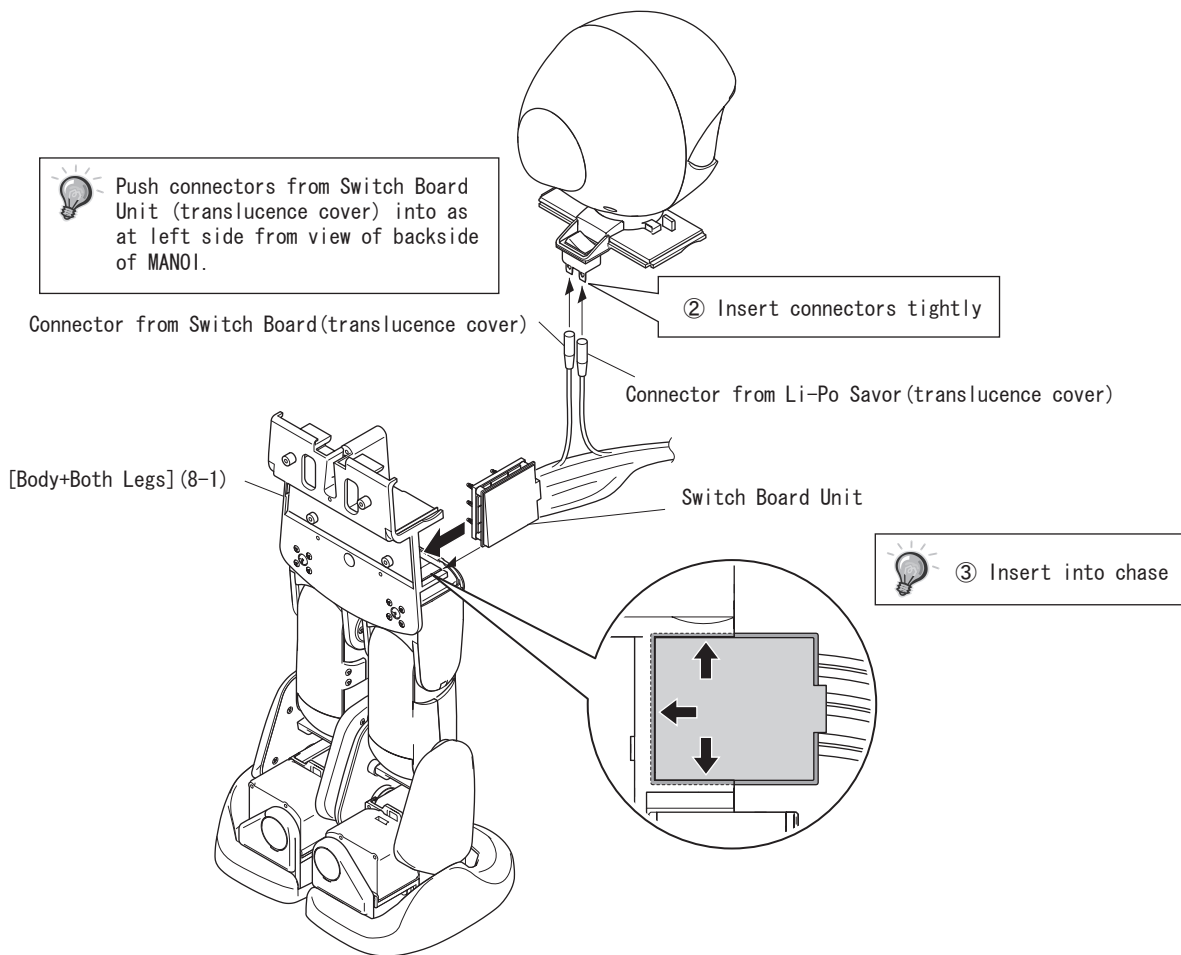

アイコン解説



注意



ポイント



締め込み注意

< { @ 確 方向注意

^ 組み立て順番



挟み込み注意



\*Follow numbers for assembling order ① [Head] Unit(7-4)

② [Left Arm] Unit(4-7)

 Check left and right of [Arm] Unit to assemble. Servo Lead at Shoulder part with CH6 is for Right Arm and Servo Lead at Shoulder part with CH2 is for Left Arm.

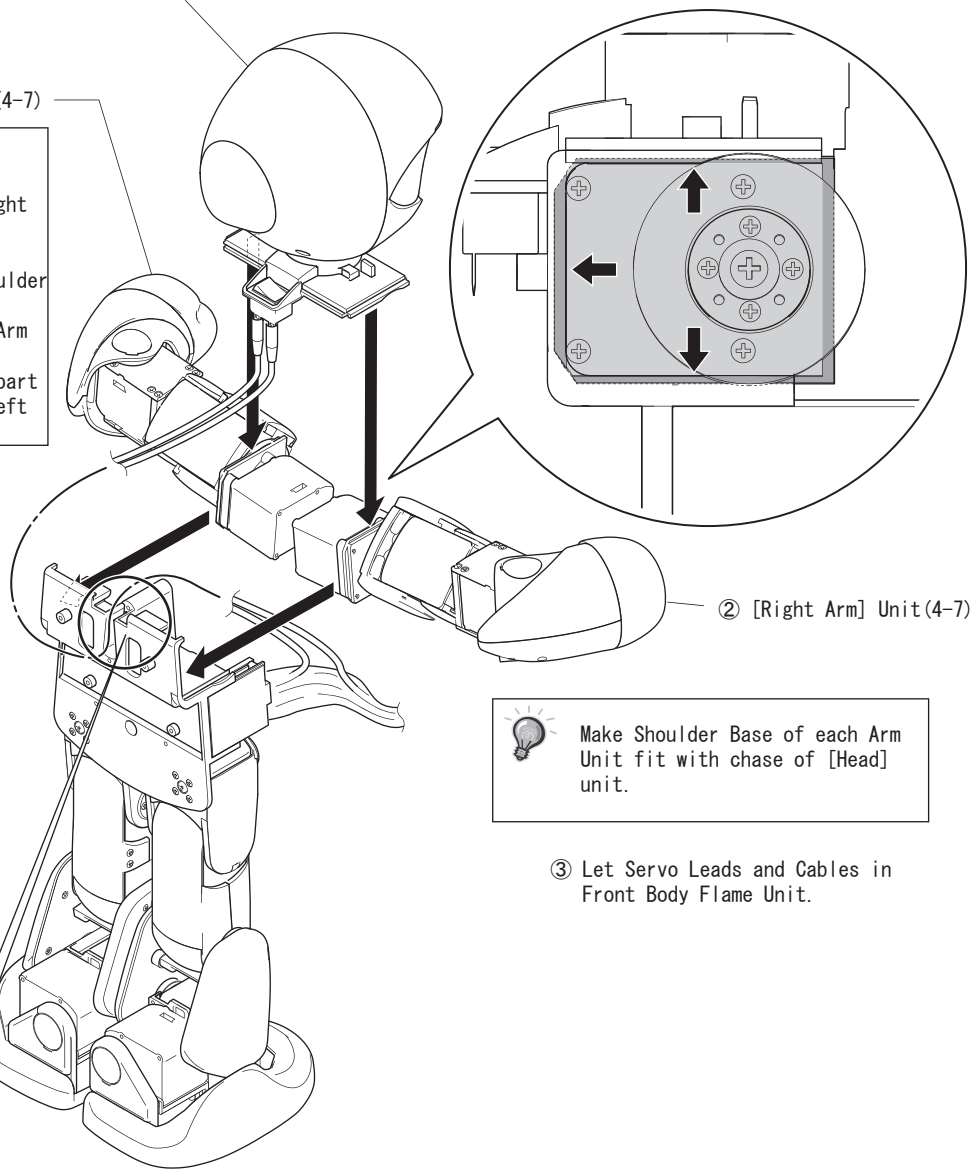

② [Right Arm] Unit(4-7)

 Make Shoulder Base of each Arm Unit fit with chase of [Head] unit.

③ Let Servo Leads and Cables in Front Body Flame Unit.

 2 cables which was connected with switch in 1 are brought to backside through slit of Neck and centre of Back Body Flame. Cables connected with Switch will not be let in hole of Back Body Flame. They will be brought to backside through between Servo Motors of fixed both arms(and under the neckbase).

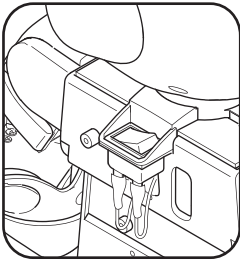

アイコン解説



注意



ポイント



締め込み注意



方向注意

組み立て順番



挟み込み注意

2 cables which was connected with switch in  are brought to backside through slit of Neck and centre of Back Body Flame s 2 together. Cables connected with Switch will not be let in hole of Back Body Flame. They will be brought to backside through between Servo Motors of fixed both arms (and under the neckbase).

Pull Servo Lead [CH1] from slit of Neck Base (same place of cable to Power Switch) out.

Pull Servo Lead [CH2] [CH3] from hole at right above from view of front side out.

Pull Servo Lead [CH4] from hole at right below from view of front side out.

Pull Servo Lead [CH7] from hole at left above from view of front side out.

Pull Servo Lead [CH6] [CH8] from hole at left below from view of front side out.

Pull Servo Lead [CH17], [CH18], [CH19], [CH20], [CH21] out.

Pull Servo Lead [CH11], [CH12], [CH13], [CH14], [CH15] out.

All cables from Switch Board Unit will be pulled out through slit of Front Body Flame Unit.

 Fit convex part of Switch Board Unit, [Body+Both Legs] Unit, [Right Arm] Unit, [Left Arm] Unit with chase of Front Body Flame unit respectively

Silliconize slightly

④ Cover by Front Body Flame Unit.

アイコン解説

 注意  ポイント  締め込み注意  方向注意  組み立て順番  挟み込み注意

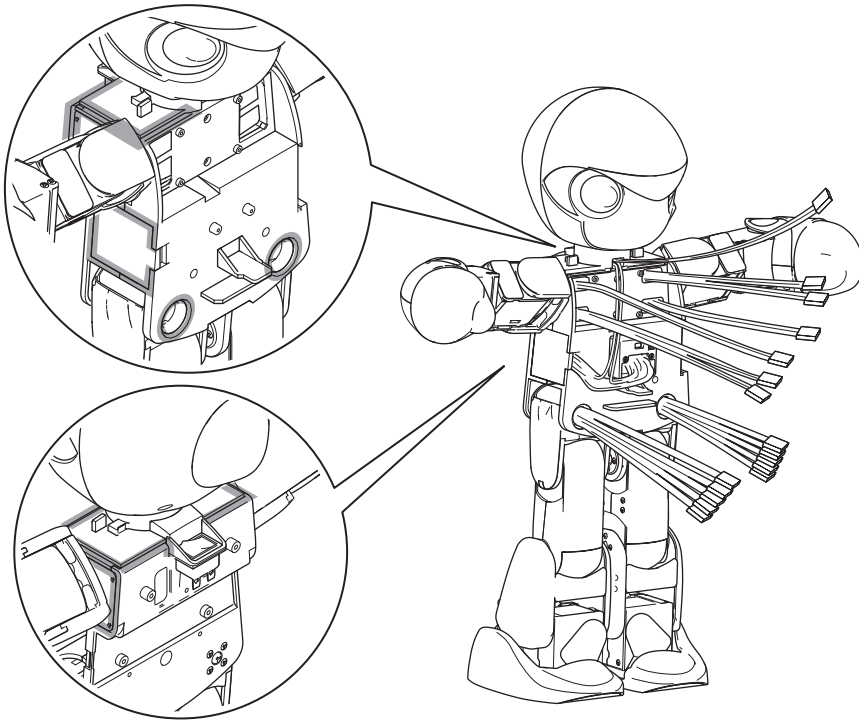

 Check below points (grey color in left views) to know if all units are assembled correctly or not.

- There is no big gap at backside of Neck.
- There is no big gap at front side of Neck.
- There is no big gap around Connector Cover.
- There is no big gap at frontside of Hip Unit and it is settled

3

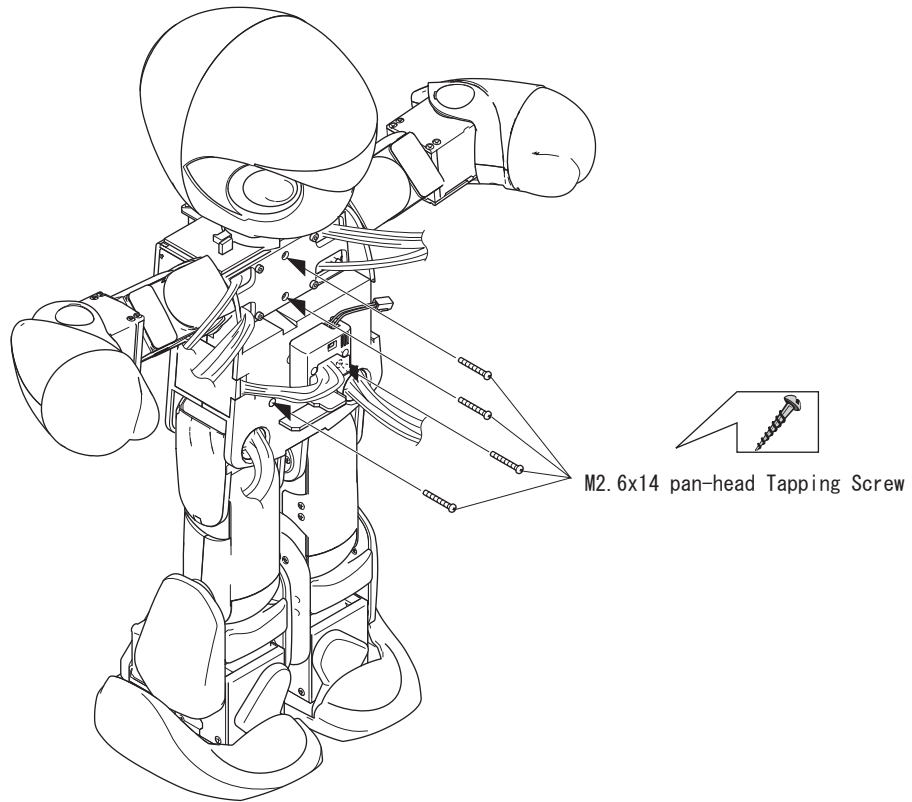

アイコン解説



注意



ポイント



締め込み注意



<

@

方向注意

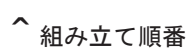

組み立て順番



挟み込み注意

## 8-3 Attaching Control Board and Wiring

Parts/Units from previous operation/step

[Whole Body] Unit (→ 8-2)

[88] Li-Po Savor (connected with Switch Board Unit)

Control Board (RCB-3) (→ 2-4)

Control Board Cover (→ 2-4)

New Parts for this step

M2 x 8 pan-head Tapping Screw x 6

1

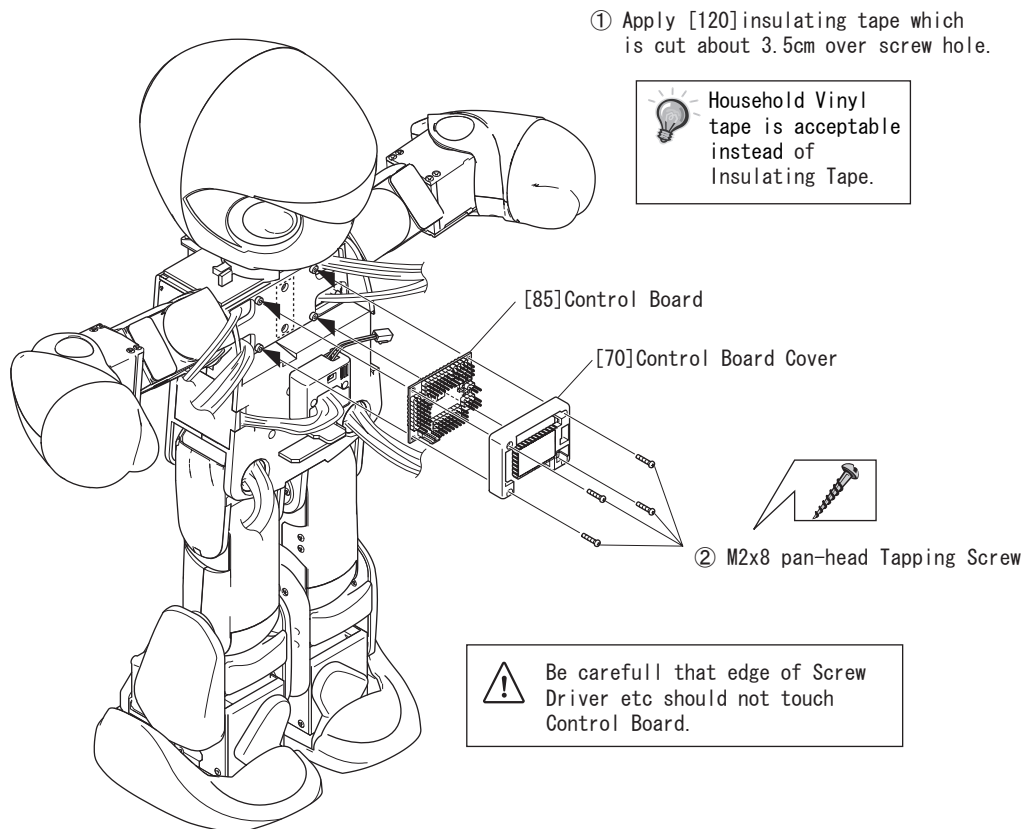

アイコン解説



注意



ポイント



締め込み注意

< @顎方向注意

^ 組み立て順番



挟み込み注意